

GAMAK



For 65 years, the *signature* of  **GAMAK**
Power to Energize Life
has shaped the future of power.

I

THE VOICE OF **GAMAK**

This work is an expression that carries the vibrational character of the GAMAK sound into a visual form. Shaped by the subtle movements of the music, this composition reflects the timeless elegance of the sound.

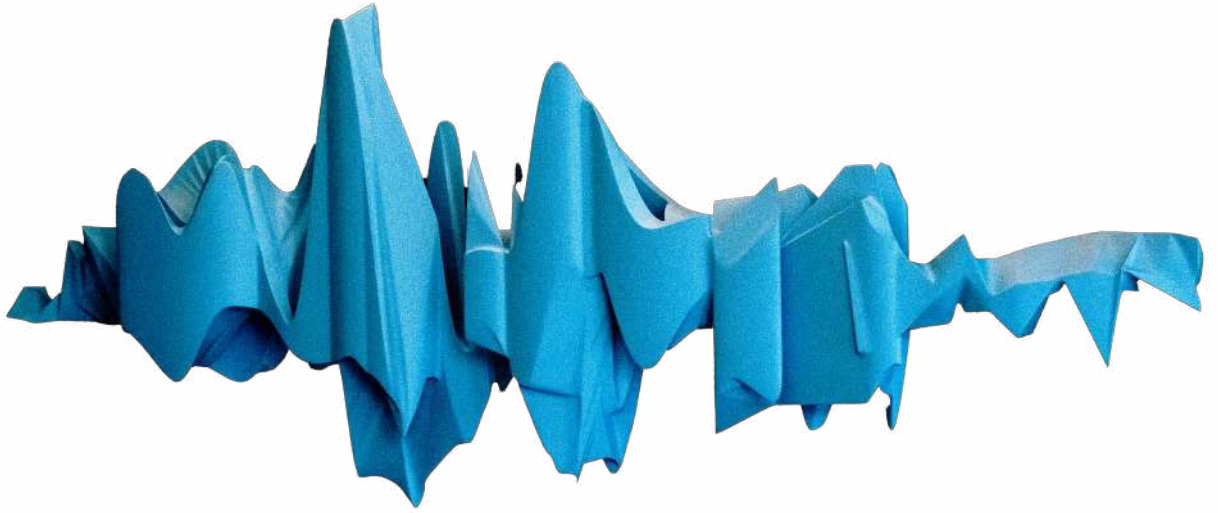

TITLE
GAMAK SOUNDWAVE
ARTIST
EBRU DÖŞEKÇİ

AT GAMAK, EVERY DETAIL LEAVES A MARK.

Because we transform the sound and vision of Gamak into the art of production. The sound of our motors is no longer only heard — it is seen. For us, production is not merely a process; it is an expression of human creativity, craftsmanship, and imagination. That is why we create meaning. Because we believe that power grows through meaning.

II

BEYOND THE
MOTOR

To leave a mark.

WE DON'T JUST MANUFACTURE MOTORS — WE LEAVE A MARK.

Every rotation begins with an intention. It finds meaning not in meeting a need, but in sustaining a value. At GAMAK, we do not simply produce electric motors. We craft an art that makes motion, power, and labor visible. We think not like a machine, but like a work of art. Every component reflects an engineer's search for solutions; every winding carries the patience of a craftsman; every detail is the embodied form of a dream. And every motor...carries the imprint of hearts beating in the same rhythm of people who believe in one another. For us, production is not a process; it is a signature...



III

LEAVING A MARK
LEADERSHIP

When a master's touch meets machine precision
and technology, GAMAK emerges.

GAMAK DOES NOT JUST MANUFACTURE MOTORS; IT CARRIES ENERGY TO THE WORLD AND POWER INTO THE FUTURE.

GAMAK was founded in 1961 with the aim of meeting Türkiye's demand for electric motors through domestic production. Since its establishment, GAMAK has operated with a vision to contribute to the development of the national industry and launched its first manufacturing facility in Topkapı, Istanbul. Today, with its modern production facility in Ümraniye, Istanbul, GAMAK stands as a leading company shaping the infrastructure of Türkiye's electric motor industry. Exporting to more than 60 countries, it has become a globally preferred solution partner. With its strong engineering capabilities, high production capacity, and continuous technological investments, GAMAK is committed to sustainable growth and to creating long-term value for industry.

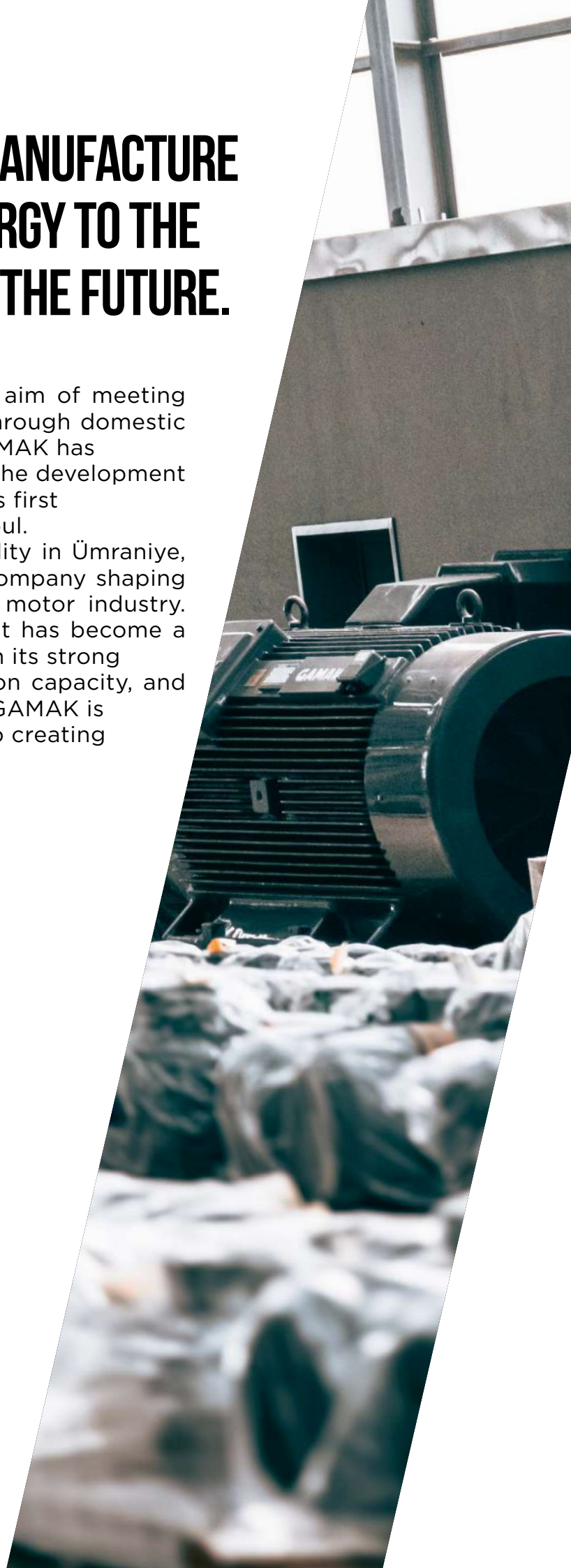

IV HISTORY

With 65 years of deep-rooted experience and future-shaping technology, we continue to stand as a symbol of power and durability.

65 years of trust

1961

Establishment



1980

New Production Facility - Dudullu
Cast Iron Workshop - Topkapı

1994

Establishment of
Test Laboratory



2017

GAMAK became an R&D center.

2022

Opening of the new service building
Start of mass production of IE4 energy efficiency class motors



2025

Smart Warehouse
Installation





V

THE ART OF **PRODUCTION**

At GAMAK, what we produce is not merely
motors; it is the powerful structure of creating
together.





PRODUCTION

Since our establishment, GAMAK has been working to empower not only machinery, but also production, development and the future. Today, our activities are not limited to industry; they are also shaped by our responsibility towards society, the environment and a sustainable future.

ART

At GAMAK, what we produce is not merely a motor; it is the powerful structure of creating together—of craftsmanship and creative intelligence. What emerges is the flawless reflection of collective effort. Because a motor is not just a machine, but the harmony of countless hands, minds, and labor that bring it into being. From engineers to operators, from technicians to quality specialists, it is the harmony of a multi-voiced collaboration. Every component is shaped millimeter by millimeter, just like a work of art— with patience, care, and intention. That is why, at GAMAK, what emerges is not simply a product, but an art of production shaped by human effort.

CONTENTS



TECHNICAL INFO

Standards and Recommendations

Mechanical Construction

Frame, End-Shields and Flanges	19
Enclosure Degree of Protections	19
Recommended Heater Power	20
Cooling (TS 3210 EN 60 034-6)	21
Terminal Box	21
Cable Entry	21
Plastic Terminal Box	21
Aluminum Terminal Box	21
Bearings	21
Standard Design with Deep Groove Ball Bearing	22
Reinforced Design with Cylindrical Roller Bearing	23
Reinforced Design with Angular Contact Ball Bearing	24
Allowable Radial Forces	25
Allowable Axial Forces	26
Shaft End	30
Vibration	30
Noise Level	30
Surface Noise Pressure Level (LpFA)	31
Paint	31
Storage	31
Mounting Arrangements (TS 3211 EN 60034-7)	34

Electrical Construction

Voltage and Frequency	35
Rated Power	36
Overloadability	36
Rated Torque	36
Insulation Class	36
Types of Operation	37
Starting Methods	39
Direct on Line	39
Indirect Start	39
Soft Start	39
Electrical Protection of Motors	39
Tolerances (IEC 60034-1)	40
Options	42
Allowable Electrical Ratings for Special Voltage Requests	43
Allowable Mechanical Dimensions for Special Shaft Requests	44

Single Phase Asynchronous Motors

Single Phase Asynchronous Motors

Permanent Circuit Capacitor Design (M22D)	48
Start + Permanent Circuit Capacitor Design (MS22D-MK22D)	48
Electronic Relay	49
Centrifugal Switch	49

Allowable Mechanic Forces	50
Frame, End-Shields and Flanges	50
Enclosure Protection Degrees	50
Terminal Box	50
Shaft End	50
Vibration	51
Paint	51
Storage	51
Bearings	51
Voltage and Frequency	51
Rated Power	52
Rated Moment	52
Changing Direction of Rotation	52
Idle Operation	52
Single Phase Asynchronous Motors / Spare Parts	53
Permanent Circuit Capacitor Design (M22D)	56
Start+Permanent Capacitor Motors/Electrical Relay (MS22D)	57
Start+Permanent Capacitor Motors/Centrifugal Switch (MK22D)	59
Single Phase Asynchronous Motors / Motor Dimensions	61
Foot Mounted Motor (IEC 60072-1) - B3, B6, B7, B8, V5, V6	61
Flanged Motor (Type "A" - IEC 60072-1) - B5, V1, V3	61
Motor With Foot Mounted and Flange (Type "A" - IEC 60072-1) - B35, V15, V36	62
Flanged Motor (Type "C" - IEC 60072-1) - B14, V18, V19	63
Flanged Motor (Type "C" - IEC 60072-1) - B34, V58, V69	63
Flanged Motor (Type "C" - IEC 60072-1) - B34-2, V58, V69	64
Three Phase Asynchronous Motors	66
Three Phase Asynchronous Motors	68
Attachable Foot	68
Fixed Foot	68
Frame, End-Shields and Flanges	68
Aluminum Frame / 2 poles - 3000 RPM / IE1	69
Aluminum Frame / 4 poles - 1500 RPM / IE1	70
Aluminum Frame / 6 poles - 1000 RPM / IE1	71
Aluminum Frame / 8 poles - 750 RPM / IE1	72
Aluminum Frame / 2 poles - 3000 RPM / IE2	73
Aluminum Frame / 4 poles - 1500 RPM / IE2	74
Aluminum Frame / 6 poles - 1000 RPM / IE2	75
Aluminum Frame / 8 poles - 750 RPM / IE2	75
Aluminum Frame / 2 poles - 3000 RPM / IE3	76
Aluminum Frame / 4 poles - 1500 RPM / IE3	77
Aluminum Frame / 6 poles - 1000 RPM / IE3	78
Aluminum Frame / 8 poles - 750 RPM / IE3	79
Aluminum Frame / 2 poles - 3000 RPM / IE4	80
Aluminum Frame / 4 poles - 1500 RPM / IE4	80
Aluminum Frame / 6 poles - 1000 RPM / IE4	81
Aluminum Frame / 8 poles - 750 RPM / IE4	81
Cast Iron Frame / 2 poles - 3000 RPM / IE1	82
Cast Iron Frame / 4 poles - 1500 RPM / IE1	82
Cast Iron Frame / 6 poles - 1000 RPM / IE1	84
Cast Iron Frame / 8 poles - 750 RPM / IE1	85
Cast Iron Frame / 2 poles - 3000 RPM / IE2	86
Cast Iron Frame / 4 poles - 1500 RPM / IE2	87
Cast Iron Frame / 6 poles - 1000 RPM / IE2	88
Cast Iron Frame / 2 poles - 3000 RPM / IE3	89
Cast Iron Frame / 4 poles - 1500 RPM / IE3	90
Cast Iron Frame / 6 poles - 1000 RPM / IE3	91

Cast Iron Frame / 8 poles - 750 RPM / IE3	92	4 poles - 1500 RPM / IE3-F300	156
Cast Iron Frame / 2 poles - 3000 RPM / IE4	93	2 poles - 3000 RPM / IE3-F400	157
Cast Iron Frame / 4 poles - 1500 RPM / IE4	94	4 poles - 1500 RPM / IE3-F400	157
Cast Iron Frame / 6 poles - 1000 RPM / IE4	95	2 poles - 3000 RPM / IE3-Pad Mounted-F300	158
Cast Iron Frame / 8 poles - 750 RPM / IE4	96	4 poles - 1500 RPM / IE3-Pad Mounted-F300	158
3 Phase Compact Asynchronous Motors	98	2 poles - 3000 RPM / IE3-Pad Mounted-F400	159
Aluminum Frame / 2 poles - 3000 RPM / IE1-IE2	99	4 poles - 1500 RPM / IE3-Pad Mounted-F400	159
Aluminum Frame / 4 poles - 1500 RPM / IE1-IE2	100	4/2 poles - 1500/3000 RPM / IE3-Double Speed-F300	160
Cast Iron / 2 poles - 3000 RPM / IE1-IE2	101	8/6 poles - 750/1500 RPM / IE3-Double Speed-F300	160
Cast Iron / 4 poles - 1500 RPM / IE1-IE2	101	Smoke Extraction Motors / Motors Dimensions	162
Aluminum Frame / 2 poles - 3000 RPM / IE3	102	Foot Mounted Motor (IEC 60072-1)-B3	162
Aluminum Frame / 4 poles - 1500 RPM / IE3	102	Flanged Motor (Form "A" - IEC 60072-1)-B5	163
Aluminum Frame / 6 poles - 1000 RPM / IE3	102	Foot Mounted and Flanged Motor (Form "A" - IEC 60072-1)-B35	164
Cast Iron Frame / 2 poles - 3000 RPM / IE3-IE4	102	Flanged Motor (Form "C" - IEC 60072-1)-B14	165
Cast Iron Frame / 4 poles - 1500 RPM / IE3-IE4	102	Flanged Motor (Form "C" - IEC 60072-1)-B14-2	165
Cast Iron Frame / 6 poles - 1000 RPM / IE3-IE4	102	Foot Mounted and Flanged Motor (Form "C" - IEC 60072-1)-B34	166
3 Phase Compact Asynchronous Motors / Spare Parts	105	Foot Mounted and Flanged Motor (Form "C" - IEC 60072-1)-B34-2	166
3 Phase Compact Asynchronous Motors / Motors Dimensions	106	Pad Mounted Smoke Extraction Motors (Form"C" - DIN EN 60072-1)-B30	167
Aluminum Motors: Foot Mounted Motor (IEC 60072-1) - B3, B6, B7, B8, B15, V5, V6	106		
Cast Iron Motors: Foot Mounted Motor (IEC 60072-1) - B3, B6, B7, B8, B15, V5, V6	107	Medium Voltage Electric Motors	168
Aluminum Motors: Flanged Motor (Form "A" - IEC 60072-1) - B5, V1, V3	108	Medium Voltage Electric Motors	170
Cast Iron Motors: Flanged Motor (Form "A" - IEC 60072-1) - B5, V1, V3	109	Medium Voltage Electric Motors Features	170
Aluminum Motors: Foot Mounted and Flanged Motor Form "A" - IEC 60072-1) - B35	110		
Cast Iron Motors: Foot Mounted and Flanged Motor (FORM "A" - IEC 60072-1) - B35	111	Milking Machine Motors	172
Aluminum Motors: Flanged Motor (Form "C" - IEC 60072-1) - B14, V18, V19	112	Milking Machine Motors	174
Cast Iron Motors: Flanged Motor (Form "C" - IEC 60072-1) - B14, V18, V19	113	Milking Machine Motors Features	174
Aluminum Motors: Foot Mounted and Flanged Motor (Form "C" - IEC 60072-1) - B34	114		
Cast Iron Motors: Foot Mounted and Flanged Motor (Form "C" - IEC 60072-1) - B34	115	Compressor Motors	176
Aluminum Motors: Flanged Motor (Form "C" - IEC 60072-1) - B14-2, V18, V19	116	Compressor Motors	178
Cast Iron Motors: Flanged Motor (Form "C" - IEC 60072-1) - B14-2, V18, V19	117	Compressor Motors Features	178
Aluminum Motors: Foot Mounted and Flanged Motor (Form "C" - IEC 60072-1) - B34-2	118		
Cast Iron Motors: Foot Mounted and Flanged Motor (Form "C" - IEC 60072-1) - B34-2	119	General Information	180
	120	Speed Control Applications	182
Ex-Proof Motors	122	Speed Adjustment of Cage Induction Motors	182
Ex-Proof Motors	122	Operating Above and Below Rated in Speed Control Applications	183
Ex-Proof Motors Features	123	Operating Below Rated Speed	183
Gamak FlameProof GG Series Ex-Proof Motors	124	Encoder Usage	184
Ex-Proof Motors / Spare Parts	126	Forced Cooling Kit	185
2 poles - 3000 RPM / IE1	127	Operation Above Rated Speed	186
4 poles - 1500 RPM / IE1	128	Shaft Tension	187
6 poles - 1000 RPM / IE1	129	Configuration Table to be Selected in Drive Applications	187
8 poles - 750 RPM / IE1	130	Operation and Maintenance Information	188
2 poles - 3000 RPM / IE2-IE3	131	Transportation	188
4 poles - 1500 RPM / IE2-IE3	132	Ventilation and Cooling	188
6 poles - 1000 RPM / IE2-IE3	133	Water Drain Holes	188
8 poles - 750 RPM / IE2-IE3	134	Interference and Elimination	188
Ex-Proof Motors / Motor Dimensions	134	Installation	188
Foot Mounted Motor - B3, B6,B7, B8, B15, V5, V6	135	Alignment	188
Flanged Motor (Form A) - B5, V1, V3	136	Waste Product Disposal	189
Flanged Motor (Form C) - B14, V18, V19	137	Clutches and Pulleys	189
Foot Mounted and Flanged Motor - B35	138	Balancing	189
Flanged Motor - B34	140	Insulation Resistance	189
		Commissioning	190
Atex 22 Motors	142	Maintenance of Bearing Housing	190
Atex 22 Motors	142	Re-lubrication of Motors with Lubrication Nipples	190
Atex 22 Motors Features	144	Bearing Replacement	191
		Seal Replacement	192
Crusher Motors	146	Possible Motor Failures and Remedies	194
Crusher Motors	146		
Crusher Motors Features	147		
Crusher Motors / Spare Parts	148		
4 poles - 3000 RPM / IE3-IE4	148		
6 poles - 1500 RPM / IE3-IE4	149		
Crusher Motors / Motor Dimensions	149		
Foot Mounted Motor - B3	150		
Smoke Extraction Motors	152		
Smoke Extraction Motors	152		
Smoke Extraction Motors Features	154		
Smoke Extraction Motors / Spare Parts	155		
Pad Mounted Smoke Extraction Motors / Spare Parts	155		
2 poles - 3000 RPM / IE3-F300	156		



**Single Phase
Asynchronous
Motors**



**Three phase
Asynchronous
Motors**



**Ex-Proof
Motors**



**Atex 22
Motors**



**Crusher
Motors**



CERTIFICATED

**Smoke
Extraction
Motors**

**Medium
Voltage
Motors**

**Milking
Machine
Motors**

**Compressor
Motors**

TECHNICAL INFORMATION



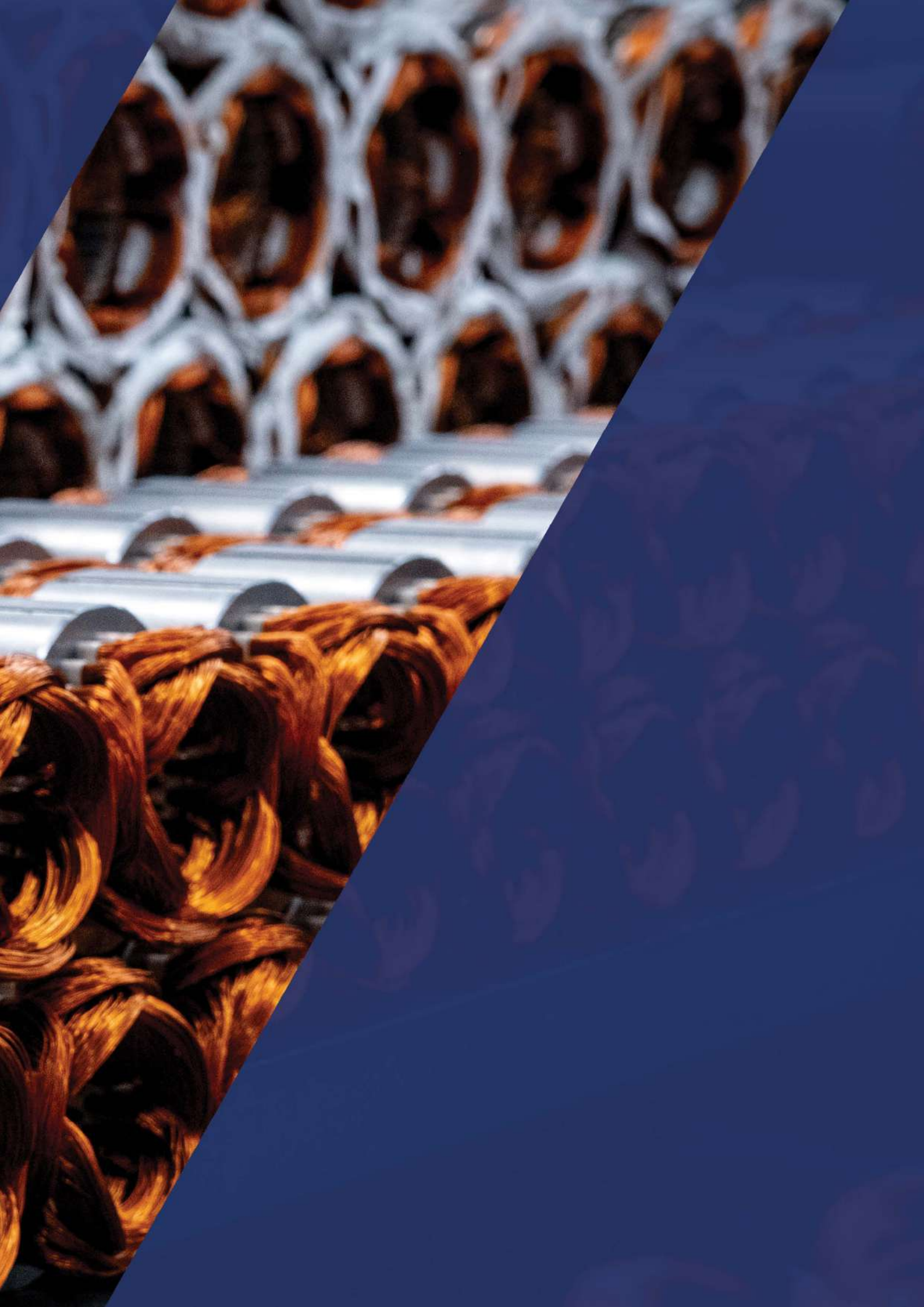

STANDARDS AND RECOMMENDATIONS

This catalog has been prepared in accordance with the recommendations of the Turkish Standards Institute “TS” and the International Electrotechnical Commission “IEC” to provide the necessary information about the mechanical and electrical values of 3-phase, cage rotor, fully enclosed, asynchronous motors manufactured for general industrial use in sizes from 63 to 630.

GAMAK induction motors are designed, manufactured and controlled in accordance with the following standards and recommendations.

TS	IEC	DIN/EN	
TS EN 60072-1	*60072-1	DIN EN 60072-1	Dimensions and output series - Part 1: Frame numbers 56 to 400 and flange numbers 55 to 1080. Cylindrical shaft ends.
TS EN 60072-1	60072-1	DIN EN 748-1	
TS EN 60034-30-1	60034-30-1	DIN EN 60034-1	Efficiency classes of line operated AC motors.
TS EN 60034-2	60034-2-1	DIN EN 60034-2-1	Standard methods for determining losses and efficiency from tests (excluding machines for traction vehicles).
TS EN 60034-5	60034-5	DIN EN 60034-5	Degrees of protection of the enclosure.
TS EN 60034-6	60034-6	DIN EN 60034-6	Cooling methods.
TS EN 60034-7	60034-7	DIN EN 60034-7	Classification of types of construction, mounting arrangements and terminal box position (IM Code).
TS EN 60034-8	60034-8	DIN EN 60034-8	Terminal markings and direction of rotation.
TS EN 60034-9	60034-9	DIN EN 60034-9	Noise limits.
TS EN 60034-11	60034-11	DIN EN 60034-11	Thermal protection.
TS EN 60034-12	60034-12	DIN EN 60034-12	Starting performance of single-speed three-phase cage induction motors.
TS EN 60034-14	60034-14	DIN EN 60034-14	Mechanical vibration of certain machines with shaft heights 56 mm and higher - Measurement, evaluation and limits of vibration severity.
TS EN 60038	60038	DIN EN 60038	IEC standard voltages.
TS EN 60085	60085	DIN EN 60085	Electrical insulation - Thermal evaluation and designation.
TS EN 60034-1	60034-1	DIN EN 60034-1	Rating and performance.
TS EN 60034-26	60034-26	DIN EN 60034-26	Effects of unbalanced voltages on the performance of three-phase cage induction motors.
-	60072-2	DIN 748-1	Dimensions and output series for rotating electrical machines - Part 2: Frame numbers 355 to 1000 and flange numbers 1180 to 2360.
-	60034-31	DIN IEC 60034-31	Selection of energy-efficient motors including variable speed applications - Application guidelines.
TS EN 60947-8	60947-8	-	Control units for built-in thermal protection (PTC) for rotating electrical machines

*IEC 60072-1 defines the dimensions and rated power of footed and flanged rotating electrical machines, respectively, and specifies the relationship between them.

MECHANICAL CONSTRUCTION

Frame, End-Shields and Flanges

The materials used in the frames, end-shields and flanges of the motors are given in the table below according to their frame sizes.

Frame Size	Frame Material	End-Shields	Flanges		
			B5	B14	B14-2
63	Aluminum	Aluminum	Aluminum	Aluminum	Aluminum
71	Aluminum	Aluminum	Aluminum	Aluminum	Aluminum
80	Aluminum	Aluminum	Aluminum	Aluminum	Aluminum
90	Aluminum	Aluminum	Aluminum	Aluminum	Aluminum
100	Aluminum	Aluminum	Aluminum	Aluminum	Aluminum
112	Aluminum	Aluminum	Aluminum	Aluminum	Cast Iron
132	Aluminum or Cast Iron	Aluminum or Cast Iron	Aluminum or Cast Iron	Cast Iron	Cast Iron
160					-
180			Cast Iron	-	-
200				-	-
225				-	-
250				-	-
280-450	Cast Iron	Cast Iron	-	-	

Aluminum frame motors with 63 frame size are produced with fixed foot 71...250 aluminum frame motors with aluminum frame are produced with attachment feet. On 132...180 motors, two lifting eyes are cast together, fixed to the frame. In addition, a lifting ring in accordance with DIN 580 can optionally be installed on motors of 160...180 frame size.

All motors of size 200...450 have a lifting ring (DIN 580).

Enclosure Degree of Protections

The degree of protection is indicated by the English initials IP for "Ingress Protection" and two characteristic numbers in accordance with TS 3209 EN 60034-5.

Icon	First Digit	Second Digit
	Protection against accidental touch and foreign object ingress	Protection against water
IP 55	Full protection against accidental touching of moving stressed parts inside the enclosure. Protection against harmful accumulation of dust. Although the ingress of dust is not completely prevented, a sufficient amount of dust is prevented from entering the enclosure to affect the operation of the motor.	Protection against damage by water sprayed on the machine from any direction.
IP 56		Protection against damage caused by water sprayed by storm or pressure on the ship deck by entering the machine.

* IP65 and IP66 production is available upon request.

Note: This standard does not End-Shields machinery intended to be operated in explosive atmospheres or special degrees of protection required by unusual operating conditions such as moisture, corrosive vapors, insects and fungi.

GAMAK electric motors are manufactured for operation in dusty and humid environments in accordance with the IP 55 degree of protection. For this reason, the motors can be operated in a End-Shieldsed outdoor environment without the need for any special precautions against mild atmospheric conditions. Motors must be protected from direct sunlight.

However, in case of extremely harsh climatic conditions such as outdoor operations, high humidity, corrosive chemicals or coastal atmospheres, the necessary protective measures as briefly described below should be taken.

-
- Special protective paint should be used,
- The degree of protection IP 56 must be applied,
- The winding heads should be protected against excessive moisture with a special coating,

For all vertical installations open to the atmosphere, the following solutions must be applied to prevent water from seeping into the motor through the shaft edges in a way that does not interfere with the cooling of the motor:

- ⚡ Shaft end down: End-Shields with an additional protective End-Shields (canopy),
- ⚡ Shaft end up: It should be End-Shieldsed with a special protective End-Shields or fitted with a bearing seal.

Measures to be taken against water condensation are as follows: The water drainage holes, which are sealed with plastic plugs, are drilled at the lowest point of the frame in accordance with the motor's construction/installation arrangement and must be kept clean at all times. If the plugs are removed, the degree of protection of the motor housing becomes IP 44.

However, for fully enclosed motors, it is best to prevent water condensation by keeping the temperature inside the frame at the specified level at all times. For this we recommend the following practices.

Two heaters of the total power recommended in the table below should be installed on the front and rear winding heads of the motor. However, the heater must be disabled before the motor is started-up

Recommended Heater Power

Frame Size	Heater	
	Voltage (V)	Power/Total (W)
71	110 or 220	16
80...100		40
112...180		60
200...280		80
315...450		120

Another solution is to apply a low voltage of 5...10% of the motor supply voltage and a current of 20...30% of the rated current to the U1 and V1 terminals by means of an autotransformer after disconnecting the voltage supplying the motor.

Cooling (TS 3210 EN 60034-6)

Motors of frame size 63...450 are cooled externally by a cooling fan operating in a perforated housing End-Shields made of sheet steel (IC 411). On the rear surface of the fan housing crown, holes are drilled for sufficient air passage in accordance with the conditions of the standard test finger. 63...355 size motors have cooling fans made of high quality reinforced Polyamide material, 315...450 size motors are made of aluminum alloy. The cooling fan is fixed to the shaft outlet at the rear of the motor and operates regardless of the direction of rotation.

Terminal Box

All terminal boxes are IP 65 rated and are located on the top front of the motor so that they can be rotated 180° for easy mains cable entry from both sides. In general construction, the motors have 6 fixed leads and there is an earthing screw in the terminal box in direct contact with the frame. The 63...180 motor end connection boxes are made of high quality reinforced Polyamide material, the 200...450 motors are made of corrosion resistant die-cast aluminum alloy. On request, the end connection boxes of motors with 71...132 structure sizes are manufactured from corrosion resistant die-cast aluminum alloy.

Cable Entry

Cable entries to the terminal box are provided by means of glands manufactured in accordance with EN 60423 and DIN EN 50 262 or, on special request, by means of Ethanol (IP 68) glands.

Plastic Terminal Box						
Frame Size	63	71-80-90	100	112	132	160-180
Cable Entry Gland	M16	M20	M25	M25	M32	M40
Number of Glands	1	1	1	2	2	2
Cable Outer Diameter (mm)	5 - 10	10-14	13-18	13-18	18-25	22-32
Maximum Conductor Wire Cross Section (mm ²)	1,5	2,5	2,5	2,5	6	16

Aluminum Terminal Box								
71-80-90	100	112	132	160-180	200-225	250-280-315	355	400-450
M20	M25	M25	M32	M40	M50	M63	PQ70	PQ70
1	1	2	2	2	2	2	2	4
10 - 14	13-18	13-18	18-25	22-32	30 -38	34-44	59	59
2,5	2,5	2,5	6	16	50	120	240	240

Bearings

The motors use high-quality, noise-controlled deep groove ball bearings (DIN 625), cylindrical roller bearings (DIN 5412) and angular contact ball bearings (DIN 628).

GAMAK electric motors come standard with a single row deep groove ball bearing design. The radial and axial forces that the standard design bearings in the bearing arrangement shown in Figures 1, 2, 3, 4, 5, 6 on the following page can withstand are given in the charts on the following page. For engines of size 132 and above, if the radial force applied to the motor shaft end exceeds the values given on page 22, a cylindrical roller bearing design with a higher radial force carrying capacity should be selected (Figure 5, Page 23).

If the axial force applied to the motor shaft end exceeds the values given in the tables, please consult us as special design may be required.

Standard Design with Deep Groove Ball Bearing

Frame Size	Number of Poles	Front Bearing Rear Bearing	Figure No.	Frame Size	Number of Poles	Front Bearing Rear Bearing	Figure No.
63	2-4	6201 ZZ-C3	1	132	2-4-6-8	6208 C3	4
71	2-4-6-8	6202 ZZ-C3		160	2-4-6-8	6309 C3	
80	2-4-6-8	6204 ZZ-C3		180	2-4-6-8	6310 C3	
90	2-4-6-8	6205 ZZ-C3		200	2-4-6-8	6312 C3	
100-112	2-4-6-8	6206 ZZ-C3		225	2-4-6-8	6313 C3	
132	2-4-6-8	6208 ZZ-C3		250	2-4-6-8	6315 C3	
160	2-4-6-8	6309 ZZ-C3 6209 ZZ-C3	2-3	280	2 4-6-8	6315 C3 6316 C3	
180	2-4-6-8	6310 ZZ-C3 6210 ZZ-C3		315	2 4-6-8	6316 C3 6318 C3	
200	2-4-6-8	6312 ZZ-C3 6212 ZZ-C3		355	2 4-6-8	6318 C3 6321 C3	
225	2-4-6-8	6313 ZZ-C3 6213 ZZ-C3		400	2 4-6-8	6318 C3 6324 C3	
250	2-4-6-8	6315 ZZ-C3 6215 ZZ-C3		450	2 4-6-8	6320 C3 6326 C3	
280	2 4-6-8	6315 ZZ-C3 6316 ZZ-C3					

Bearing Arrangements

Lubrication Nipples

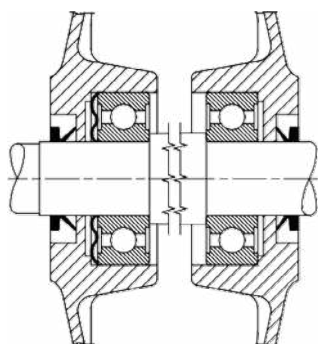
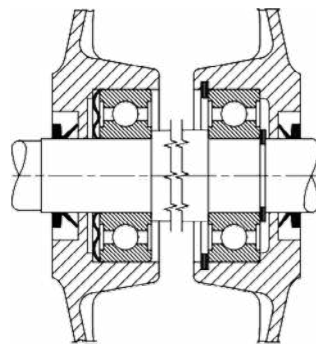
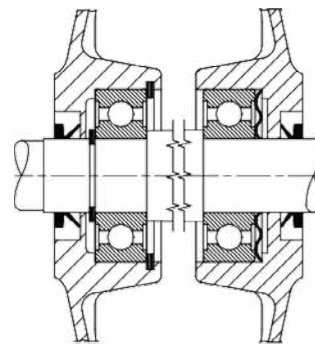
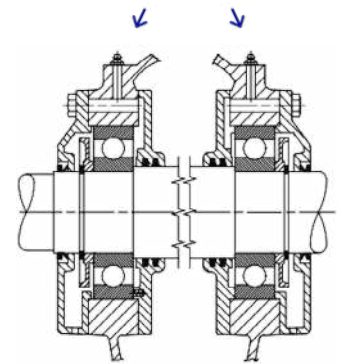
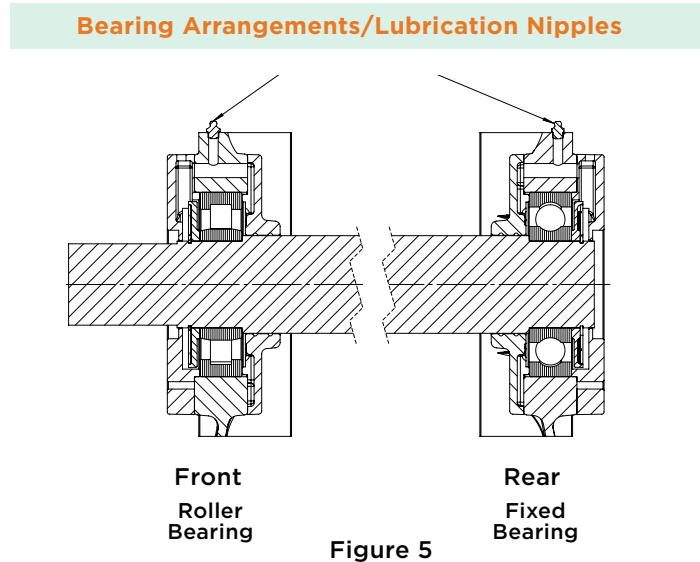

Figure 1
Front
Rear
Free bearing (Spring tensioned) **Free Bearing**

Figure 2
Front
Rear
Free bearing (Spring tensioned) **Fixed bearing**

Figure 3
Front
Rear
Fixed bearing **Free bearing (Spring tensioned)**

Figure 4
Front
Rear
Free bearing (Spring tensioned) **Fixed bearing**

- The axial clearance of deep groove ball bearing housings is limited by a pre-tensioned spring (bearing thrust spring - Fig. 1, 2, 3) or coil springs (Fig. 4). This minimizes bearing vibrations and noise and increases bearing life.
- 63...132 motors (Table 1) and 160...280 motors (Tables 2 and 3) use deep groove ball bearings closed on both sides (ZZ), lubricated for life by the manufacturer.
- 63...132 motors are manufactured in standard production with ZZ closed bearings with the bearing thrust spring in front as shown in Figure 1 and without locking according to Table 1.
- 160...280 motors are manufactured in standard production with ZZ closed bearings with the bearing thrust spring in front as shown in Figure 2 and with rear locking according to Tables 2 and 3.
- Motors of 315...450 frame size are manufactured in standard production as shown in figure 4, with locking of the front and rear oil splitter disks and lubricated bearings and locking from the front and rear according to Table 4. On type 315 and above, coil springs are used at the front instead of bearing compression springs. The bearings used are open type ball bearings with nipples for lubrication during operation.
- Motors with frame sizes 63...280, for shaft-down mounting positions (V1-V5-V18-V15-V58-V8), are manufactured in accordance with Table 1, Table 2 and Table 3, with ZZ sealed bearings, arranged as shown in Figure 3, with the front bearing fixed (locating bearing) and the rear bearing floating (non-locating bearing), with the bearing preloading spring located at the rear.
- Motors with frame sizes 63...280, for shaft-up mounting positions (V6-V3-V19-V36-V69-V9), are manufactured in accordance with Table 1, Table 2 and Table 3, with ZZ sealed bearings, arranged as shown in Figure 2, with the front bearing floating (non-locating bearing), with the bearing preloading spring located at the front, and the rear bearing fixed (locating bearing).
- The aim here is to prevent the shaft from moving in the axial direction in accordance with the conditions required by the application. The bearing arrangement is referred to as a fixed bearing.
- In line with special customer demand, motors in 132...280 frame sizes are produced as shown in Figure 4 with front and rear locking according to Table 4, with locking of the front and rear oil-deflecting discs and lubricated bearings as shown in Figure 4. The bearing thrust spring used is located at the front.
- Standard motors are produced with co-bearing (closed ZZ bearing structure or lubricated) between 63...132 types and 280...450 types.
- In the co-roller bearing arrangement, the bearing used on the rear side is designed to be the same as the bearing used on the front side.
- In accordance with special customer request, we can produce co-bearing motors for higher permissible axial forces in 160...250 type motors.
- In line with special customer demand, in case of double output motor demand in 160...250 type motors, production can be made with co-bearing design.

Reinforced Design with Cylindrical Roller Bearing (For High Radial Forces)

For motors of size 132 and above, please consult us if belt/pulley drive is used, as you may need to select the cylindrical roller bearing design.

Frame Size	Number of Poles	Front Bearing	Rear Bearing	Figure No.
132	2-4-6-8	NU 208 E	6208 C3	5
160	2-4-6-8	NU 309 E	6309 C3	
180	2-4-6-8	NU 310 E	6310 C3	
200	2-4-6-8	NU 312 E	6312 C3	
225	2-4-6-8	NU 313 E	6313 C3	
250	2-4-6-8	NU 315 E	6315 C3	
280	2	NU 315 E	6315 C3	
	4-6-8	NU 316 E	6316 C3	
315	2	NU 316 E	6316 C3	
	4-6-8	NU 318 E	6318 C3	
355	2	NU 318 E	6318 C3	
	4-6-8	NU 321 E	6321 C3	
400	2	NU 318 E	6318 C3	
	4-6-8	NU 324 E	6324 C3	
450	2	NU 320 E	6320 C3	
	4-6-8	NU 326 E	6326 C3	



In motors using the cylindrical roller bearing (NU series) design, if the radial force is too small during operation, slippage will occur between the rolling surfaces of the bearing and the rollers, which will cause the rollers to skid, thus shortening the bearing life. If the radial force is too small or there are severe shock loads or vibration, please consult us as special bearing construction may be required. Motors of 132...450 frame sizes are manufactured in a reinforced design with cylindrical roller bearings, construction with lubrication nipple (Fig. 5). Allowable radial forces are given on page 22 and axial forces on pages 25-26.

Reinforced Design with Angular Contact Ball Bearing (For High Axial Forces)

For motors of frame size 315 and above, please consult us as you may need to select an angular contact ball bearing design for high axial force requirements in the shaft up-and-down operation type. Motors of 400 and above frame sizes are provided with angular contact ball bearing design as standard in shaft up-and-down operation type.

Frame Size	Number of Pole	Front Bearing	Rear Bearing	Figure No.
315	2	7316 B	6316 C3	6
	4-6-8	7318 B	6318 C3	
355	2	7318 B	6318 C3	
	4-6-8	7321 B	6321 C3	
400	2	7318 B	6318 C3	
	4-6-8	7324 B	6324 C3	
450	4-6-8	7326 B	6326 C3	

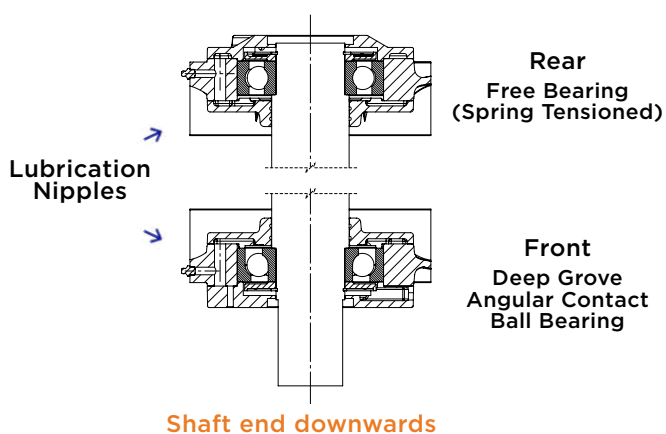

Figure 6

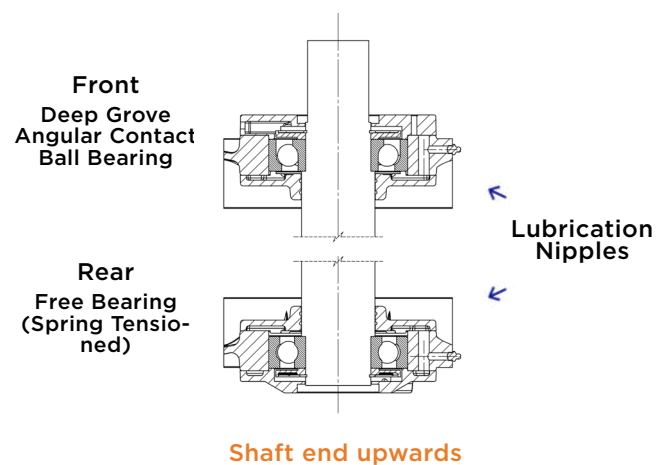

Figure 7

The angular contact ball bearing (7xxx Series) design is used in the up-and-down shaft operation of the motor. It is preferred when high axial loads are required. Since angular contact ball bearings can carry axial forces in only one direction, the bearing installation varies depending on the shaft end direction. Due to the nature of the installation in the motor, only downward axial forces can be carried. 315....450 motors are manufactured in a reinforced design with angular contact ball bearings with lubrication nipples (see Figure 6 - Figure 7).

Allowable radial loads are given on page 22 and axial forces on page 23.

Allowable Radial Forces

F_r = Radial force (N)

X = Distance between the shaft bill and the force application point (mm).

X_{max} = The shaft is equal to the pulley length. The pulley axis must remain within the shaft length measurement.

X_0 = Represents the point where the shaft pulley invoice starts.

P : Motor power (kW)

n : Speed at full load (r/min) D : Pulley diameter (mm)

k : Belt tension coefficient (approx.)

- For drive with flat belt and idler pulley: $k=2$
- For V-belt drive: $k=2.25$
- For drive without idler pulley with flat belt and multiple V-belts: $k=3$

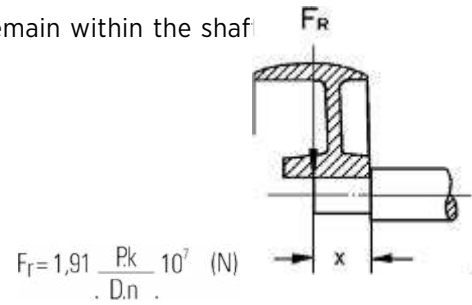

Standard Design with Deep Groove Ball Bearing (Axial Force $F_a = 0$)

Frame Size	3000 RPM		1500 RPM		1000 RPM		750 RPM	
	X_0 N	X_{max} N	X_0 N	X_{max} N	X_0 N	X_{max} N	X_0 N	X_{max} N
63	350	300	450	390	-	-	-	-
71	400	340	510	430	580	490	640	540
80	660	540	840	680	980	800	1070	880
90	740	600	930	760	1070	870	1190	970
100	1040	830	1310	1050	1500	1210	1670	1340
112	1040	840	1300	1050	1490	1210	1650	1340
132	1520	1220	1940	1560	2220	1790	2490	2000
160	2800	2230	3520	2800	4050	3220	4470	3560
180	3230	2630	4090	3330	4710	3830	5180	4210
200	4290	3540	5450	4500	6220	5140	6900	5700
225	4780	3980	6030	4810	6880	5500	7650	6100
250	5800	4730	7330	6000	8420	6870	9230	7540
280	5770	4800	7860	6610	9040	7600	10100	8480
315	6000	5100	8760	7270	9910	8220	11100	9180
355	6700	5800	10400	8620	12300	10100	13700	11300
400	5800	5100	10700	9060	12400	10500	14000	11900
450	*	*	11900	10300	13900	12000	15700	13600

Reinforced Design with Cylindrical Roller Bearing (Axial Force $F_a = 0$)

Frame Size	3000 RPM		1500 RPM		1000 RPM		750 RPM	
	X_0 N	X_{max} N	X_0 N	X_{max} N	X_0 N	X_{max} N	X_0 N	X_{max} N
132	3900	3100	4800	3800	5500	4400	6000	4800
160	6890	5490	8480	6750	9620	7660	10500	8370
180	7730	6270	9540	7750	10800	8790	11800	9580
200	10600	8740	13100	10800	14700	12200	16100	13300
225	12600	10500	15600	12400	17600	14000	19300	15400
250	16700	13700	20700	16900	23400	19100	25400	20700
280	16800	14200	22100	18600	25000	21000	27400	23000
315	18000	15500	28900	23700	32600	26800	35600	29200
355	23500	20200	26100	21500	29700	24500	32600	26900
400	22500	19800	36400	30900	41200	35000	44800	38000
450	*	*	40800	35400	46300	40100	50800	44000

* Available upon request.

Strengthened Design with Angular Contact Ball Bearing (Axial Force Fa=0)

Frame Size	3000 RPM		1500 RPM		1000 RPM		750 RPM	
	X ₀ N	X _{max} N	X ₀ N	X _{max} N	X ₀ N	X _{max} N	X ₀ N	X _{max} N
315	7400	6500	10800	9300	12500	10700	13700	11700
355	8600	7500	13900	11700	15900	13300	17500	14800
400	8500	7500	15200	13000	17200	14900	19000	16400
450	-	-	17500	15200	20200	17500	22200	19300

Allowable Axial Forces

Allowable axial external forces
Standard design with deep groove ball bearing

Frame Size	Horizontal Shaft				Vertical Shaft												
	Pulling	Pushing			Shaft / Down						Shaft / Up						
		F _r =0	max.F _r		F _r =0	Force Down			Force Up			F _r =0	Force Down			Force Up	
	X ₀ 'da		X _{max} 'da	X ₀ 'da		X _{max} 'da	F _r =0	X ₀ 'da	X _{max} 'da	F _r =0	X ₀ 'da		X _{max} 'da	F _r =0	X ₀ 'da	X _{max} 'da	F _r =0
N	N	N	N	N	N	N	N	N	N	N	N	N	N	N	N	N	

2 poles - 3000 RPM

63	80	170	150	220	70	70	70	180	150	230	160	140	210	90	90	90
71	100	190	160	240	90	90	90	200	170	250	170	140	230	110	110	110
80	140	320	270	410	120	120	120	340	280	430	300	250	400	160	160	160
90	160	350	290	430	130	130	130	370	320	470	310	250	410	190	190	190
100	220	490	400	590	170	170	170	520	440	650	430	340	560	270	270	270
112	220	490	410	590	160	160	160	530	450	660	420	340	550	280	280	280
132	350	710	580	820	200	200	200	820	690	1000	530	400	700	500	500	500
160	1650	1090	840	1230	850	850	1470	1270	1010	1530	720	530	910	1690	1430	1950
180	1820	1190	920	1300	1000	980	1550	1460	1190	1760	650	460	900	1980	1710	2270
200	2590	1910	1590	2090	1200	1200	2230	2270	1940	2670	950	700	1200	2770	2440	3170
225	2820	2070	1730	2260	1300	1300	2390	2510	2150	2970	800	500	1150	3070	2710	3530
250	3120	2410	1950	2580	1600	1510	2530	3000	2520	3540	800	400	1200	3530	3060	4080
280	5200	4420	4040	4670	1300	1300	3500	5250	4810	5950	3180	2740	3880	5780	5350	6490
315	5090	4780	5050	5090	2710	2290	2410	4500	4500	6800	2710	2290	3410	7110	6690	7810
355	5670	5300	5710	5670	1000	1000	3270	6100	6100	8700	3600	3300	3600	8300	8000	8600
400	-	-	-	-	-	-	-	-	-	-	-	-	-	-	-	-
450	-	-	-	-	-	-	-	-	-	-	-	-	-	-	-	-

4 poles - 1500 RPM

63	80	270	240	330	70	70	70	270	240	350	260	230	330	90	90	90
71	100	290	250	360	90	90	90	300	260	370	270	230	340	110	110	110
80	140	490	420	610	120	120	120	510	440	640	460	390	590	160	160	160
90	160	540	460	650	120	120	120	570	490	700	490	410	620	200	200	200
100	220	740	630	880	150	150	150	790	680	970	660	540	830	290	290	290
112	220	750	640	870	130	130	130	810	700	980	640	530	810	310	310	310
132	350	1090	920	1240	180	180	180	1210	1040	1450	880	710	1120	520	520	520
160	2110	1510	1180	1690	1250	1200	1880	1740	1400	2090	1050	780	1300	2160	1820	2510
180	2340	1660	1310	1820	1400	1260	2020	1990	1620	2380	1000	650	1300	2510	2140	2900
200	3370	2610	2180	2870	1800	1990	2970	3020	2570	3560	1550	1220	1900	3520	3070	4060
225	3650	2860	2300	3090	1900	1900	3100	3410	2840	4030	1200	820	1600	3970	3400	4590
250	4060	3290	2680	3520	2300	1980	3340	4010	3380	4740	1400	750	1900	4550	3920	5270
280	7060	6720	6240	7060	2000	2000	5500	6700	6700	8980	4900	4290	5910	7970	7360	8980
315	7840	7440	7390	7840	2200	2350	5750	7400	7500	10400	4620	3870	5750	10200	9420	11300
355	9410	8950	9700	9410	2100	2100	5330	9200	9200	13300	6200	5600	6300	12700	12100	13200
400	-	-	-	-	-	-	-	-	-	-	-	-	-	-	-	-
450	-	-	-	-	-	-	-	-	-	-	-	-	-	-	-	-

Allowable axial external forces
Standard design with deep groove
ball bearing

Frame Size	Horizontal Shaft				Vertical Shaft											
	Pulling	Pushing			Shaft / Down						Shaft / Up					
		max.F _r		F _r =0	Force Down			Force Up			Force Down			Force up		
	X ₀ 'da	X _{max} 'da	X ₀ 'da		X _{max} 'da	F _r =0	X ₀ 'da	X _{max} 'da	F _r =0	X ₀ 'da	X _{max} 'da	F _r =0	X ₀ 'da	X _{max} 'da	F _r =0	
N	N	N	N	N	N	N	N	N	N	N	N	N	N	N	N	

6 poles - 1000 RPM

71	100	360	320	450	80	80	80	380	330	470	340	300	430	120	120	120
80	140	630	550	770	110	110	110	660	570	810	590	500	740	170	170	170
90	160	680	580	810	110	110	110	710	610	870	620	520	770	210	210	210
100	220	940	800	1100	140	140	140	1000	850	1200	840	700	1050	300	300	300
112	220	940	810	1090	120	120	120	1010	880	1220	810	680	1010	320	320	320
132	350	1370	1170	1560	150	150	150	1520	1310	1800	1130	920	1410	550	550	550
160	2470	1840	1450	2040	1580	1370	2190	2120	1720	2530	1360	950	1580	2540	2140	2950
180	2730	2010	1590	2210	1800	1480	2380	2360	1930	2830	1300	860	1630	2880	2450	3340
200	3920	3130	2620	3420	2300	2290	3450	3610	3080	4240	2000	1550	2400	4110	3580	4740
225	4240	3450	2800	3680	2500	2120	3540	4160	3470	4890	1750	1250	2200	4720	4030	5250
250	4750	3940	3220	4210	3060	2320	3920	4780	4030	5630	1800	1100	2450	5310	4570	6170
280	8340	7950	7340	8340	2600	2600	7090	7600	7700	10500	5900	5180	7090	9280	8560	10500
315	9170	8700	8790	9170	3200	3400	6600	8000	8100	12000	5260	4380	6600	11500	11300	12000
355	11100	10600	11300	11100	1600	1600	6940	10000	10000	15200	6400	5700	6700	14500	13800	15000
400	-	-	-	-	-	-	-	-	-	-	-	-	-	-	-	-
450	-	-	-	-	-	-	-	-	-	-	-	-	-	-	-	-

8 poles - 750 RPM

71	100	420	370	520	80	80	80	440	390	540	400	350	500	120	120	120
80	140	730	630	880	110	110	110	750	650	920	680	590	860	170	170	170
90	160	800	690	950	110	110	110	830	720	1010	740	620	920	210	210	210
100	220	1100	940	1300	140	140	140	1160	1000	1400	1000	840	1240	300	300	300
112	220	1100	940	1270	120	120	120	1170	1020	1400	970	810	1200	320	320	320
132	350	1610	1380	1850	180	180	180	1740	1500	2070	1390	1160	1720	520	520	520
160	2760	2090	1640	2340	1820	1570	2480	2360	1910	2820	1600	1150	1950	2780	2330	3240
180	3040	2290	1820	2520	2130	1640	2650	2680	2190	3200	1610	1130	2000	3200	2710	3720
200	4410	3550	2970	3910	2700	2630	3940	4020	3430	4730	2730	2130	3050	4520	3930	5230
225	4780	3870	3130	4220	2900	2550	4140	4510	3750	5340	2450	1990	3000	5070	4310	5700
250	5290	4440	3640	4750	3430	2600	4390	5340	4500	6300	2700	1900	3400	5880	5040	6840
280	9480	8990	8230	9480	3500	3400	8280	8400	8000	11600	6930	6120	8280	10200	9400	11600
315	10400	9880	9790	10400	3600	3700	7860	9200	9300	13800	6350	5360	7860	13300	12300	13800
355	12700	12100	12600	12700	3100	3100	8510	11400	11400	17000	8500	7800	8800	16200	15500	17000
400	-	-	-	-	-	-	-	-	-	-	-	-	-	-	-	-
450	-	-	-	-	-	-	-	-	-	-	-	-	-	-	-	-

Allowable axial external forces Standard design with cylindrical roller bearings

Frame Size	Horizontal Shaft				Vertical Shaft											
	Pulling	Pushing			Shaft / Down						Shaft / Up					
	F _r =0	max.F _r		F _r =0	max.F _r		F _r =0	max.F _r		F _r =0	max.F _r		F _r =0	max.F _r		F _r =0
		X ₀ 'da	X _{max} 'da		X ₀ 'da	X _{max} 'da		X ₀ 'da	X _{max} 'da		X ₀ 'da	X _{max} 'da		X ₀ 'da	X _{max} 'da	
N	N	N	N	N	N	N	N	N	N	N	N	N	N	N	N	N

2 poles - 3000 RPM

132	1370	1100	750	1370	960	620	1290	1200	850	1520	960	620	1290	1200	850	1520
160	2450	2040	1440	2450	1740	1140	2270	2220	1620	2750	1740	1140	2270	2220	1620	2750
180	2820	2400	1780	2820	1750	1330	2550	2680	2050	3280	1950	1330	2550	2680	2050	3280
200	3710	3160	2380	3710	2300	1650	2700	3520	2730	3900	2300	1650	2700	3520	2730	3900
225	4150	3480	2590	4150	2770	1870	3500	3920	3020	4870	2770	1870	3500	3920	3020	4870
250	5000	4150	2880	5000	3200	1920	4200	4750	3460	5960	3200	1920	4200	4750	3460	5960
280	5180	4080	2950	4650	3230	2090	3800	5470	4330	6040	3230	2090	3800	5470	4330	6040
315	5180	5010	3910	5180	2770	1650	3300	6420	5300	7050	2770	1650	3300	6420	5300	7050
355	5670	5660	4620	5670	2150	690	2700	8470	7020	9000	2150	690	2700	8470	7020	9000
400	-	-	-	-	-	-	-	-	-	-	-	-	-	-	-	-
450	-	-	-	-	-	-	-	-	-	-	-	-	-	-	-	-

4 poles - 1500 RPM

132	1820	1500	1040	1820	1280	830	1700	1610	1160	2020	1280	830	1700	1610	1160	2020
160	3240	2720	1940	3240	2320	1540	3010	2950	2160	3640	2320	1540	3010	2950	2160	3640
180	3760	3200	2390	3760	2650	1830	3440	3530	2710	4310	2650	1830	3440	3530	2710	4310
200	4950	4200	3180	4950	3250	2500	3750	4610	3580	5150	3250	2500	3750	4610	3580	5150
225	5520	4650	3250	5520	3710	2300	4600	5210	3800	6460	3710	2300	4600	5210	3800	6460
250	6640	5540	3880	6640	4340	2660	5650	6270	4600	7860	4340	2660	5650	6270	4600	7860
280	7100	6200	4630	7100	4440	3130	6040	7270	5960	8870	4440	3130	6040	7270	5960	8870
315	7840	7340	5220	7840	3910	1770	4950	9460	7320	10600	3910	1770	4950	9460	7320	10600
355	9410	9540	7920	9410	3280	1200	5330	12900	11400	13700	3280	1200	5330	12900	11400	13700
400	-	-	-	-	-	-	-	-	-	-	-	-	-	-	-	-
450	-	-	-	-	-	-	-	-	-	-	-	-	-	-	-	-

6 poles - 1000 RPM

132	2160	1770	1250	2160	1550	1030	2040	1890	1390	2380	1550	1030	2040	1890	1390	2380
160	3840	3240	2320	3840	2760	1830	3570	3520	2600	4330	2760	1830	3570	3520	2600	4330
180	4460	3790	2850	4460	3180	2230	4100	4150	3190	5070	3180	2230	4100	4150	3190	5070
200	5820	4960	3780	5820	3950	2950	4500	5450	4250	6050	3950	2950	4500	5450	4250	6050
225	6500	5530	3900	6500	4330	2680	5800	6240	4590	7710	4330	2680	5800	6240	4590	7710
250	7860	6580	4640	7860	5170	3210	6700	7420	5460	9280	5170	3210	6700	7420	5460	9280
280	8390	7320	5460	8390	5370	3490	6900	8490	6610	10400	5370	3490	6900	8490	6610	10400
315	9170	8740	6270	9170	4440	1920	6600	11300	8830	12350	4440	1920	6600	11300	8830	12350
355	11100	11300	9300	11100	4540	2110	5650	14500	12750	15600	4540	2110	5650	14500	12750	15600
400	-	-	-	-	-	-	-	-	-	-	-	-	-	-	-	-
450	-	-	-	-	-	-	-	-	-	-	-	-	-	-	-	-

Allowable axial external forces Standard design with cylindrical roller bearings

Frame Size	Horizontal Shaft				Vertical Shaft											
	Pulling	Pushing			Shaft / Down						Shaft / Up					
		max.F _r		F _r =0	Force Down			Force Up			Force Down			Force Up		
	X _o 'da		X _{max} 'da		X _o 'da	X _{max} 'da	F _r =0	X _o 'da	X _{max} 'da	F _r =0	X _o 'da	X _{max} 'da	F _r =0	X _o 'da	X _{max} 'da	F _r =0
N	N	N	N	N	N	N	N	N	N	N	N	N	N	N	N	

8 poles - 750 RPM

132	2450	2000	1400	2450	1790	1200	2340	2090	1500	2650	1790	1200	2340	2090	1500	2650
160	4340	3640	2620	4340	3150	2130	4060	3910	2890	4820	3150	2130	4060	3910	2890	4820
180	5010	4270	3210	5010	3590	2530	4620	4660	3590	5690	3590	2530	4620	4660	3590	5690
200	6580	5590	4260	6580	4770	3430	5450	6070	4730	6800	4770	3430	5450	6070	4730	6800
225	7360	6180	4370	7360	5080	3240	6720	6830	4990	8480	5080	3240	6720	6830	4990	8480
250	8800	7370	5220	8800	5830	3660	7910	8270	6100	10400	5830	3660	7910	8270	6100	10400
280	9510	8210	6140	9510	6310	4210	8400	9340	7240	11500	6310	4210	8400	9340	7240	11500
315	10400	9760	7000	10400	5440	2630	7450	12300	9540	14100	5440	2630	7450	12300	9540	14100
355	12700	12800	10300	12700	5830	3120	7700	16400	14400	17300	5830	3120	7700	16400	14400	17300
400	-	-	-	-	-	-	-	-	-	-	-	-	-	-	-	-
450	-	-	-	-	-	-	-	-	-	-	-	-	-	-	-	-

Allowable axial external forces Standard design with angular contact ball bearing

Frame Size	Horizontal Shaft				Vertical Shaft											
	Pulling	Pushing			Shaft / Down						Shaft / Up					
		max.F _r		F _r =0	Force Down			Force Up			Force Down			Force Up		
	X _o 'da		X _{max} 'da		X _o 'da	X _{max} 'da	F _r =0	X _o 'da	X _{max} 'da	F _r =0	X _o 'da	X _{max} 'da	F _r =0	X _o 'da	X _{max} 'da	F _r =0
N	N	N	N	N	N	N	N	N	N	N	N	N	N	N	N	

2 poles - 3000 RPM

315	-	-	-	-	7600	7600	13000	-	-	-	8200	8200	13000	-	-	-
355	-	-	-	-	8000	8000	13900	-	-	-	8400	8400	13900	-	-	-
400	-	-	-	-	5500	5500	11300	-	-	-	6000	6000	11300	-	-	-
450	-	-	-	-	-	-	-	-	-	-	-	-	-	-	-	-

4 poles - 1500 RPM

315	-	-	-	-	11000	11000	19000	-	-	-	12000	12000	19000	-	-	-
355	-	-	-	-	14600	14600	24500	-	-	-	15600	15600	24500	-	-	-
400	-	-	-	-	13200	13200	24000	-	-	-	14200	14200	24000	-	-	-
450	-	-	-	-	10000	10000	22000	-	-	-	11000	11000	22000	-	-	-

6 poles - 1000 RPM

315	-	-	-	-	13500	13500	22500	-	-	-	14500	14500	22500	-	-	-
355	-	-	-	-	16000	16000	27000	-	-	-	17000	17000	27000	-	-	-
400	-	-	-	-	14000	14000	26400	-	-	-	15500	15500	26400	-	-	-
450	-	-	-	-	12000	12000	23000	-	-	-	14000	14000	23000	-	-	-

8 poles - 750 RPM

315	-	-	-	-	14700	14700	24400	-	-	-	15700	15700	24500	-	-	-
355	-	-	-	-	19000	19000	31500	-	-	-	20500	20500	31500	-	-	-
400	-	-	-	-	16000	16000	29500	-	-	-	17800	17800	29500	-	-	-
450	-	-	-	-	15000	15000	23000	-	-	-	17000	17000	23000	-	-	-

● All values are:

Based on L10 bearing shelf-life of at least 20.000 hours.
For 50 Hz frequency.

● For 60 Hz network, please consult.

* Please consult for these values.

Shaft End

In our standard production, the shaft end of the motors is single-sided and a suitable wedge is installed (TS EN 60072-1 / IEC60072-1). In addition, the shaft end is threaded in accordance with DIN 332-2 form “D”. On request, motors can be manufactured with shaft ends on both sides. The runout of the shaft end, the concentricity of the flange bill and the perpendicularity of the surface are within the normal class limits specified in TS EN 60072-1 / IEC 60072-1. On request, manufacturing is also made in “Sensitive class” tolerance.

Vibration

The dynamic balancing of the rotors of our standard motors is done in accordance with the normal mechanical vibration class specified in DIN EN 60034 - 14, complete with a HALF KEY placed at the shaft end. For this reason, the dynamic balance of the transmission elements such as pulleys, gears, clutches, etc. attached to the shaft end of the motor and the propeller must be taken on a flat head before the keyway is opened.

Degree of Vibration	Installation	56 ≤ H ≤ 132 mm		H > 132 mm	
		Relocation (μm)	Speed (mm/s)	Relocation (μm)	Speed (mm/s)
A	Free Hanger	45,00	2,80	45,00	2,80
	Rigid assembly	-	-	37,00	2,30
B	Free Hanger	18,00	1,10	29,00	1,80
	Rigid assembly	-	-	24,00	1,5 (or 1.8*)

*Grade A applies to machines with no special vibration requirements.

*Grade B, Applies to machines with special vibration requirements.

*Rigid mounting is not suitable for machines with a shaft height of 132 mm or less.

Noise Level

The noise level limits for general purpose electrical machines are specified in TS EN 60034-9. The noise level of GAMAK electric motors is well below these limits. There are 3 main sources of noise:

1. Magnetic forces: Forces the stator pack to vibrate in the radial direction.
2. Bearings: Balls and rollers make noise due to geometrical distortion.
3. Cooling fan: Produces noise called ventilation noise.

The most common of these 3 main noise sources is usually the fan. This is especially noticeable in large motors. Special measures can be taken to reduce noise on request. The noise emitted in the air environment is determined in a soundproof and anechoic test chamber in accordance with DIN EN 21 680-1. The surface sound pressure level (Lp_{fA}) in dB (A) is the average of the sound pressure values read on the “A” scale of the sound measuring device at different locations 1 m from the engine surface. Tolerance +3dB (A). The following values are valid for a mains frequency of 50 Hz. For 60 Hz the values increase by about 4dB (A).

Surface Noise Pressure Level (L_{pfA})

Frame Size	2 pole dB(A)	4 pole dB(A)	6 pole dB(A)	8 pole dB(A)
63	54	45	-	-
71	58	49	44	44
80	58	53	47	48
90	64	56	51	51
100	67	58	53	53
112	68	59	57	56
132	70	63	61	61
160	72	65	64	62
180	74	66	65	63
200	76	68	66	65
225	79	69	67	65
250	79	70	68	66
280	80	73	70	68
315	82	78	73	72
355	85	79	76	74
400	86	80	77	76
450	88	81	79	78

Paint

Gamak electric motors are painted with RAL 7031 (DIN 1843) gray protective paint. It complies with ISO 12944 C3M class. On request, a special outer paint resistant to extremely humid atmosphere, chemicals and micro-organisms is applied. Different color, different category (C4, C5) options are available upon request.

Storage

If the motors are to be stored for long periods of time, they should be kept in clean, well ventilated places without moisture, vibration and their insulation resistance should be measured and the windings should be dried if necessary before commissioning.



INNOVATION
IN TECHNOLOGY
HIGH STANDARDS
IN PRODUCTION





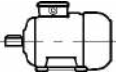
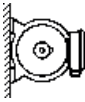
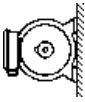
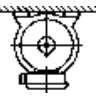

Mounting Arrangements (TS 3211 EN 60034-7)

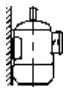
Foot-Mounted

Figure	Icon	Description	Frame Size
	IM B3 IM 1001	Floor mounted.	63...450L
	IM B6 IM 1051	Wall mounted. Seen from the drive side foot mounted on the left	63...315M
	IM B7 IM 1061	Wall mounted. Seen from the drive side foot mounted on the right	63...315M
	IM B8 IM 1071	Ceiling mounted	63...315M
	IM V5 IM 1011	Wall mounted. Shaft end downwards.	63...315M
	IM V6 IM 1031	Wall mounted. Shaft end upwards.	63...315M

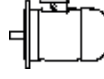
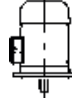
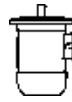
Without Foot, With Flange

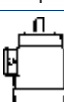
Figure	Icon	Description	Frame Size
	IM B5 IM 3001	Flange mounted. Flange form A, "FF"	63...315M
	IM V1 IM 3011	Flange mounted at the bottom. A, "FF" Shaft end downwards.	63...450L
	IM V3 IM 3031	Flange mounted at the top. A, "FF" Shaft end upwards.	63...315M
	IM B14 IM 3601	Flange mounted. Flange form C, "FT"	63...160L
	IM V18 IM 3611	Flange mounted at the bottom. Flange form C, "FT". Shaft end downwards.	63...160L
	IM V19 IM 3631	Flange mounted at the top. Flange form C, "FT". Shaft end upwards.	63...160L

Foot-Mounted, with Flange

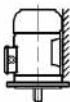
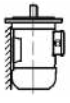
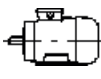
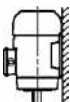
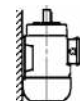
Figure	Icon	Description	Frame Size
	IM B35 IM 2001	Floor mounted, flanged connection. Flange form A, "F"	63...450L
	IM V15 IM 2011	Wall mounted, flanged connection. Flange form A, "F" Shaft end downwards.	63...315L
	IM V36 IM 2031	Wall mounted, flanged connection. Flange form A, "F" Shaft end upwards.	63...315M
	IM B34 IM 2101	Floor mounted, flanged connection. Flange form C, "FT"	63...160L
	IM V58 IM 2111	Wall mounted, flanged connection. Flange form C, "FT" Shaft end downwards.	63...160L
	IM V69 IM 2131	Wall mounted, flanged connection. Flange form C, "FT" Shaft end upwards.	63...160L

Without Foot, Without Front End-Shields (Pad Mounted)

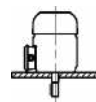
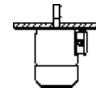
Figure	Icon	Description	Frame Size
	IM B9 IM 9101	Frame mounted at the front end.	63...315M
	IM V8 IM 9111	Frame mounted at the front end. Shaft end downwards.	63...450L
	IM V9 IM 9131	Frame mounted at the front end. Shaft end upwards.	63...315M

Without Foot, Without Front End-Shields

Figure	Icon	Description	Frame Size
	IM B15 IM 1201	Floor mounted, connection from frame front.	63...450L

Without Foot, With Front End-Shields (Pad Mounted)

Figure	Icon	Description	Frame Size
	IM B30 IM 9201	4 separate points on the frame	80-100L

ELECTRICAL CONSTRUCTION

Voltage and Frequency

Motors are manufactured according to 400 V rated voltage and 50 Hz frequency as standard, upon request, they can be manufactured according to voltages up to 110-660 V and frequencies of 50-60 Hz. Variations of $\pm 5\%$ in rated voltage and $\pm 2\%$ in frequency practically do not cause any change in motor power. The temperature of the motors operating continuously at the lower and upper limits of the permissible voltage change can exceed the maximum 10K above the permissible temperature rise limit according to the winding insulation class. Motors manufactured for 50 Hz frequency can usually be connected to a network with a frequency of 60 Hz. In this case, to find the new operating values at various voltages, the catalog values are multiplied by the approximate coefficients given in the table.

50 Hz		60 Hz							
		Operating values at full load							
Nominal Voltage V	Network Voltage V	Power	Speed	I_N	M_N	I_A/I_N	M_A/M_N	M_K/M_N	I_0
230	230	1	1,2	1	0,83	0,87	0,75	0,85	0,73
	*230	1,15	1,2	1,15	0,96	0,98	0,93	1	1,12
	250	1,1	1,2	1	0,91	0,96	0,83	0,94	0,85
	264	1,15	1,2	1	0,96	1	0,93	1	0,93
400	400	1	1,2	1	0,83	0,87	0,75	0,85	0,73
	*400	1,15	1,2	1,15	0,96	0,98	0,93	1	1,12
	440	1,1	1,2	1	0,91	0,96	0,83	0,94	0,85
	460	1,15	1,2	1	0,96	1	0,93	1	0,93
	480	1,2	1,2	1	1	1,03	0,98	1,03	0,98
415	415	1	1,2	1	0,83	0,87	0,75	0,85	0,73
	*415	1,15	1,2	1,15	0,96	0,98	0,93	1	1,12
	460	1,1	1,2	1	0,92	0,98	0,90	0,96	0,87
	480	1,15	1,2	1	0,96	1	0,93	1	0,93
500	500	1	1,2	1	0,83	0,87	0,75	0,85	0,73
	*500	1,15	1,2	1,15	0,96	0,98	0,93	1	1,12
	550	1,1	1,2	1	0,92	0,98	0,90	0,96	0,87
	575	1,15	1,2	1	0,96	1	0,93	1	0,93
	600	1,2	1,2	1	1	1,03	0,98	1,03	0,98

*Special winding for 60 Hz.

I_N : Rated Current I_0 : Current Under No Load M_A : Star-up Torque I_A : Star-up Current M_N : Rated Torque M_K : Overturning Torque

60 Hz specially motors should be selected based on the following standard powers. Depending on the power and speed of the motors, power increases up to 20% are possible. Therefore, please consult for power requests higher than those listed in the table below.

Standard Power at 50 Hz (kW)	Standard Power at 60 Hz (kW)	Standard Power at 50 Hz (kW)	Standard Power at 60 Hz (kW)	Standard Power at 50 Hz (kW)	Standard Power at 60 Hz (kW)
0,06	0,07	4	4,6	90	103
0,09	0,105	5,5	6,3	110	126
0,12	0,14	7,5	8,6	132	152
0,18	0,21	11	12,7	160	184
0,25	0,29	15	17,3	200	230
0,37	0,43	18,5	21,3	250	288
0,55	0,63	22	25,3	315	360
0,75	0,86	30	34,5	355	410
1,1	1,27	37	42,6	400	460
1,5	1,73	45	51,8	450	515
2,2	2,5	55	63,5	500	575
3	3,5	75	86,5		

Please consult for the power values to be obtained in the special winding above 500 kW rated power and 60 Hz.

According to IEC 60034-30 standard, efficiency values are determined separately for each power in 50Hz and 60Hz operation. Please consult for the efficiency values of motors wound according to 50Hz if they are operated at 60Hz or if the motors are specially wound according to 60Hz.

Rated Power

The Rated power P_N is the mechanical power given at the shaft of the motor at the rated values indicated on the nameplate of the motor. The effective power P_1 is the power that the motor draws from the grid and is greater than the mechanical power it delivers on the shaft due to losses. $P_1 (W) = \sqrt{3} \cdot U \cdot I \cdot \cos \phi$

Efficiency (η) is the mechanical power divided by the effective power. The efficiency values given in the catalog are calculated by summing the losses according to IEC 60034-2-1:2024 (For more detailed information, see page 36).

The rated powers given in this catalog are the mechanical power delivered at the shaft of the motor at rated voltage and frequency, at 40°C ambient temperature, at altitudes up to 1000 m above sea level and in continuous operation (S1). Standard GAMAK motors, manufactured with insulation class F, have the following variations in rated power when operated at ambient temperatures exceeding 40°C and at altitudes of more than 1000 m.

Ambient Temperature	°C	<30	30-40	45	50	55	60
Rated Power	%	107	100	95	90	85	80

Height	m	1000	2000	3000	4000
Rated Power	%	100	95	90	80

If the ambient temperature and height both change, multiply the rated power by the coefficients for height and temperature to find the new permissible power. If the power reduction exceeds 15%, the operating characteristics of the motor will be unfavorable due to the low utilization factor. Please consult us in this case. At altitudes above 1000 m, if the ambient temperature of 35°C drops by the following amounts for every 100 m increase in altitude, the rated power remains unchanged.

1.0°C for insulation class F

1.25°C for insulation class H

Overloadability

If an overcurrent of 1.5 times the rated current is passed through a standard induction motor operating at regime temperature at 15 minute intervals and for 2 minutes, no temperature rise will occur to damage the motor windings. Standard asynchronous motors, when operating at rated voltage and frequency, can withstand gradually increasing instantaneous excessive moments up to 1.6 times the rated moment for 15 seconds. Overloads of longer duration than those described above depend on the size and temperature rise characteristics of the motor, the duration and frequency of the overload, and whether the overload is applied when the motor is running cold or at steady-state temperature.

Rated Torque

Torque taken from the motor shaft:

$$\text{Rated Torque (Nm)} = 9550 \frac{\text{Rated Power (kW)}}{\text{Rated Speed (d/dak)}}$$

1 kgf m = 9,81 Nm ~ 10 Nm

Motor torque at starting must always be higher than the counter torque of the driven machine.

Insulation Class

In our standard production, motors are insulated with Class F insulation up to 315 Type and Class H above 315. Although the permissible temperature rise limit of Class F is 105K using the resistance method, GAMAK motors are designed to operate within the Class B limit (80K) for longer life and better performance. This allows motors up to 160 frame (included) to withstand ambient temperatures of 60°C and larger motors up to 55°C, or alternatively to increase their power by 15% and 10% respectively, or to withstand harsh supply voltage conditions. On request, motors can be manufactured in the superior insulation class H (125K). The round copper enameled coil wire used in our standard production is produced in two layers (2L) enameled. The first layer is enameled with polyesterimide in thermal class "H" (180°C) and the second layer is enameled with polyamide-imide in thermal class "N + C" (200°C).

The motor windings are dipped in a synthetic varnish (polyester) of class H to increase resistance to vibration and provide superior heat permeability, and then baked and dried. The windings of the motors we manufacture as standard are insulated for tropical climatic conditions. Thus, in addition to normal climatic conditions, it can be used in places with moderate humidity and is resistant to aggressive gases, steam and oily environments. On request, winding insulation is made to withstand 95% relative humidity.

Types of Operation

The operating regime is a working program that includes the periods and sequence of application of the loads applied to the motor together with the periods of idle running and stopping. The type of operating regime is the order of the motor operating with one or more specific loads that do not change in specified periods. Electric motors are manufactured in accordance with a wide range of operating conditions. Standard operating regime types are classified in TS 3067/ IEC 60 034-1.

S1: Continuous Operation

Operation the motor under constant load until it reaches thermal equilibrium.

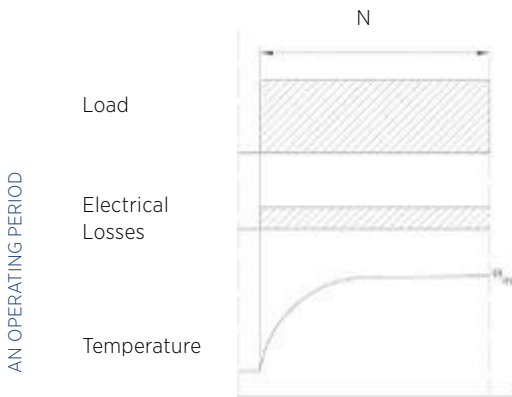

S2: Short Continuous Operaiton

Operation the motor under constant load for a period not long enough to reach thermal equilibrium and then stopping until it cools down to ambient temperature. Operating time is recommended at 10, 30, 60 and 90 minutes.

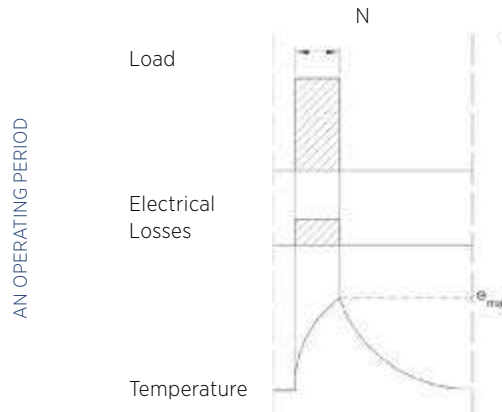

S3: Intermittent Operation at Intervals

It consists of a sequence of identical working periods. Each period is divided into two parts, one running under constant load and the other stopping. The inrush current does not produce a temperature rise. Working period duration is 10 minutes unless otherwise agreed. The relative running time is 15%, 25%, 40% and It is envisaged as 60%.

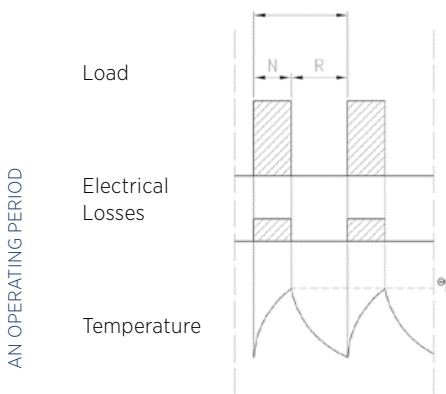

S6: Continuous Operation at Inervals

It consists of a sequence of identical operating periods. Each period is divided into two parts, one under constant load and one without load. There is no stopping in this type of operation. The working periods are too short to reach thermal equilibrium. The duration of the working period is 10 minutes unless otherwise agreed. The relative working time is envisaged as 15%, 25%, 40% and 60% of a period.

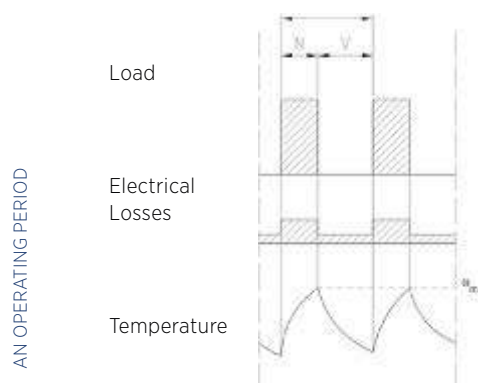

N: Operation at rated conditions
D: Starting
F: Electrical braking
L: Operation under variable loads
R: Stop
V: Idling
S: Operation under overload
Cp: Full load

Relative Operating Time

It is the ratio of the operating time of the motor at load, including the starting and electrical braking periods, expressed as a percentage of the period duration.

Coefficient for the Torque of inertia= $\frac{J_M / J_Z}{J_M}$

JM : Torque of inertia of the motor (kgm²).

Jz : Total Torque of inertia of the work machine and fittings such as the coupling relative to the motor shaft (kgm²).

It should also be specified whether the type of braking is mechanical or electrical [direct current braking or alternating current braking (by changing the direction of rotation of the motor)].

The operating values given in the catalog refer to continuous operation (S1). However, as standard the motors we manufacture in S1 type can operate in all other types of operation, provided that they do not exceed the highest permissible temperature value.



**POWER
TO
ENERGIZE
LIFE**

Starting Methods

Direct on Line

The easiest way to start a caged induction motor is to connect the motor directly to the grid. The only necessary starting equipment is the direct starter. In this most preferred method, due to the high starting current, the rules and limitations of the electricity authorities must be observed.

Number of Poles	Rated power (kW) limits at 400 V, 50 Hz	
	220-240 V (Δ) / 400 V (Y)	400 (Δ)
2 ve 4	≤3 kW	≥ 3,7kW
6	≤2,2 kW	≥ 3kW
8	≤1,5 kW	≥ 2,2kW
Methods For Start-Up	Direct	Y / Δ or others

Indirect Start

Star-delta start can be used if the start-up current of the motor is greater than the mains limit value. In delta connection, a motor that is wound according to the mains phase-phase voltage (e.g. 380V, 400V) is started in star connection. This reduces the starting current and torque to about 1/3 of the direct starting value. In order to limit the current and torque pulses when changing from star to delta, the transition should take place as close as possible to the rated speed of the motor (93...95%). However, it is possible to reduce the high starting current of large motors to some extent with stepped star-delta (Y / Δ / Δ) clamping.

Soft Start

In some cases, soft starting of motors is desired and the starting current is not important. Then a soft starter can be used. In this way, the starting time can be adjusted for soft starting and the motor operation can be continuously monitored and adjusted according to the voltage requirement, thus minimizing losses. When a soft starter is used, the torque curve of the motor must match the characteristics of the work machine.

Electrical Protection of Motors

In motors, winding temperatures should not be allowed to exceed the defined values. Therefore, the thermal protection of the windings should be selected to best suit the operating conditions. In general, motors are protected by circuit breakers or overload relays with bimetal mechanisms providing delayed overcurrent protection. However, this protection is particularly effective during starting. Furthermore, motors are also protected against excessive temperature rise for any reason by thermostats, which are bimetal switches placed in the windings, and thermistors, which are semiconductor temperature sensors. Thermistor protection is safer than other motor protection schemes because it controls the temperature at the winding, which is the most critical point, regardless of external factors and type of operation. Fuses normally protect only the system and not the motor.

Tolerances (IEC 60034-1)

Efficiency

Motors up to 150 kW	: P≤150 kW	-0,15 (1 - η)
Motors bigger than 150 kW	: P>150 kW	-0,10 (1 - η)W

Power Coefficient cos φ	$\frac{1 - \cos \phi}{6}$	min. 0,02 max. 0,07
--------------------------------	---------------------------	------------------------

Slipping (at full load and operating temperature)	For PN < 1 kW motors, ± %30 is allowed. For PN ≥ 1 kW motors, ± %20 is allowed.
--	--

Starting Current	+ %20
-------------------------	-------

Starting Torque	From %15 to + %25 (With special agreement +%25 can be exceeded.)
------------------------	--

Breakdown Torque	%10 (Even after this tolerance ratio is applied, the maximum torque should not be less than 1.6 times the Rated torque.)
-------------------------	--

Moment of Inertia	± %10
--------------------------	-------

Noise Limit	+ 3dB (A)
--------------------	-----------

In the table below you can see the efficiency classes specified in the IEC 60034-30-1:2014 standard.

IE4 Super Premium IE3 Premium (Very High) Efficiency IE2 High Efficiency IE1 Standard Efficient	IEC 60034-30-1:2014	0,12-1000 kW 2,4,6 and 8 pole motors
--	---------------------	---

According to the communique updated on July , 2023 , the following cases efficiency class will be applied.

- Three-phase and single-phase motors designed for continuous operation (including S3≥80% and eS6≥80%)
- Rated voltage minimum 50V maximum 1000V and operating at 50 Hz, 60 Hz or 50/60 Hz sinusoidal voltage,
- Altitude 4000 m above sea level, ambient temperature up to 60 °C,
- Motors that are fully integrated into a product such as gearboxes, pumps, fans and compressors are End-Shielded by the new communiqué if the efficiency test can be performed independently of the product. (For example, efficiency classes are also applied to motors that are coupled to the gearbox with a special shaft and/or End-Shields).

For 3-phase motors, you can find the summary table below showing the efficiency classes determined according to power and number of poles.

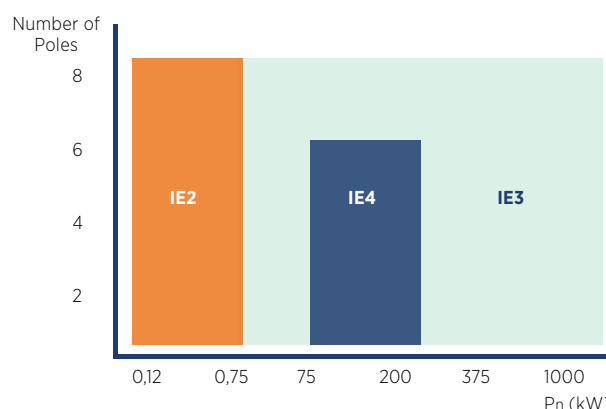

Ex-Proof motors (Ex ec, Ex tb, Ex db, Ex db eb and Ex dc), broke motors and fully enclosed through air cooled (TEAO) are End-Shielded by the notification. The 75-200kW IE4 requirement applies only to 2-4-6 pole single speed motors (excluding braked motors, Ex eb increased safety or other ex-proof motors) In addition, 1-phase motors in the range 0.12-1000kW and Ex eb motors must be in efficiency class IE2.

IEC 60034-2-1:2024 specifies the methods to be used for the determination of losses and efficiency of electric motors. The measurement methods specified in the standard, where more precise measurement and calculation methods are used for the calculation of additional losses, are as follows.

Test Standard

- Direct measurement method
- Indirect measurement method
- The additional losses (PLL) are determined based on test results at different load ratings.
- For motors from 0.1 kW to 1000 kW, additional losses (PLL) are taken into account in the range of 2.5 to 1% of the input power.

The tests for determining the efficiency class of the motors are based on the test results of the indirect measurement method at different load ratings of the additional losses.

Options	63	71	80	90	100	112	132	160	180	200	225	250	280	315	355	400	450
- Mounting Arrangements																	
B5, V1,V3 (Aluminum)	O	O	O	O	O	O	O	O	N/A	N/A	N/A	N/A	N/A	N/A	N/A	N/A	N/A
B5, V1,V3 (Cast Iron)	N/A	N/A	N/A	N/A	N/A	N/A	O	O	O	O	O	O	O	O	O	O	O
B14/ B14-2 (Alumium)	O	O	O	O	O	O	N/A	N/A	N/A	N/A	N/A	N/A	N/A	N/A	N/A	N/A	N/A
B14 (Cast Iron)	N/A	N/A	N/A	N/A	N/A	N/A	O	O	N/A	N/A	N/A	N/A	N/A	N/A	N/A	N/A	N/A
B14-2 (Cast Iron)	N/A	N/A	N/A	N/A	N/A	N/A	O	N/A	N/A	N/A	N/A	N/A	N/A	N/A	N/A	N/A	N/A
- Special Winding	O	O	O	O	O	O	O	O	O	O	O	O	O	O	O	O	O
- Special Shaft																	
According to Drawing	R	R	R	R	R	R	R	R	R	R	R	R	R	R	R	R	R
Rear Shaft Output **	O	O	O	O	O	O	O	O	O	O	O	O	O	O	O	O	O
- IP 56 - 65 - 66	O	O	O	O	O	O	O	O	O	O	O	O	O	O	O	O	O
- Roller Bearing (NU) - 2 / 4-6 8 P	N/A	N/A	N/A	N/A	N/A	N/A	O	O	O	O	O	O	O	O	O	O	O
- Angular Contact Ball Bearing 7000 Series 2 / 4-6 8 P	N/A	N/A	N/A	N/A	N/A	N/A	O	O	O	O	O	O	O	O	O	O	O
- H Isolation	O	O	O	O	O	O	O	O	O	O	O	O	O	S	S	S	S
- Forced Cooling	N/A	O	O	O	O	O	O	O	O	O	O	O	O	O	O	O	O
- Heater - 1AC 110 V -1 AC 220 V	O	O	O	O	O	O	O	O	O	O	O	O	O	O	O	O	O
- Canopy	O	O	O	O	O	O	O	O	O	O	O	O	O	O	O	O	O
- Motor Protection																	
2xPTC	O	O	O	O	O	O	O	O	O	O	O	O	O	O	O	O	O
3xPTC	O	O	O	O	O	O	O	S	S	S	S	S	S	S	S	S	S
3xPTO in Winding	O	O	O	O	O	O	O	O	O	O	O	O	O	O	O	O	O
3xPT-100 in Winding	O	O	O	O	O	O	O	O	O	O	O	O	O	O	O	O	O
2xPT-100 Bearing	N/A	N/A	N/A	N/A	N/A	N/A	O	O	O	O	O	O	O	O	O	O	O
- Greaseble Nipple	N/A	N/A	N/A	N/A	N/A	N/A	O	O	O	O	O	O	O	S	S	S	S
- Insulated Bearing	N/A	N/A	N/A	N/A	N/A	N/A	O	O	O	O	O	O	O	O	O	O	O
- Common Bearings	S	S	S	S	S	S	S	O	O	O	O	O	S	S	S	S	S
- Aluminum Terminal Box	N/A	O	O	O	O	O	O	O	O	S	S	S	S	S	S	S	S
- Water Drain Holes (Condensate hole)	O	O	O	O	O	O	O	O	O	O	O	O	O	O	O	O	O
- Oil Seal	S	S	S	S	S	S	S	S	S	S	S	S	S	S	S	S	S
- Vibration Nipple	N/A	N/A	N/A	N/A	N/A	N/A	O	O	O	O	O	O	O	O	O	O	O
- Metal Cable Gland	O	O	O	O	O	O	O	O	O	O	O	O	O	O	S	S	S
- Encoder	R	R	R	R	R	R	O	O	O	O	O	O	O	O	O	O	O
- Tropic Protection	O	O	O	O	O	O	O	O	O	O	O	O	O	O	O	O	O
- Paint - with Ral Code	O	O	O	O	O	O	O	O	O	O	O	O	O	O	O	O	O
- Brake	O	O	O	O	O	O	O	O	O	O	O	O	O	O	O	O	O

NOTE: Some variant codes cannot be used together.

S : Standard Features

O : Optional Features

R : On Request

N/A : Not applicable

**Ask for rear double output shaft for IE4 motors over 315.

Allowable Electrical Ratings for Special Voltage Requests

Type/Pole	Std. Voltage (Δ)	Min. Voltage (Δ)	Max. Voltage (Δ)	Frequency (Hz)	Power Increase
63/2	230	220	440	50 - 60	1 - 1,15
63/4	230	127	400	50 - 60	1 - 1,15
71/2	230	220	440	50 - 60	1 - 1,15
71/4	230	220	575	50 - 60	1 - 1,15
71/6	230	230	440	50 - 60	1 - 1,15
71/8	230	230	230	50 - 60	1 - 1,15
80/2	230	220	600	50 - 60	1 - 1,15
80/4	230	220	575	50 - 60	1 - 1,15
80/6	230	127	440	50 - 60	1 - 1,15
80/8	230	220	230	50 - 60	1 - 1,15
90/2	230	220	480	50 - 60	1 - 1,15
90/4	230	127	575	50 - 60	1 - 1,15
90/6	230	220	500	50 - 60	1 - 1,15
90/8	230	230	230	50 - 60	1 - 1,15
100/2	230	110	440	50 - 60	1 - 1,15
C.100/2	400	230	500	50 - 60	1 - 1,15
100/4	230	120	600	50 - 60	1 - 1,15
C.100/4	400	230	440	50 - 60	1 - 1,15
100/6	230	127	575	50 - 60	1 - 1,15
100/8	230	220	400	50 - 60	1 - 1,15
112/2	400	220	500	50 - 60	1 - 1,15
112/4	400	127	575	50 - 60	1 - 1,15
112/6	230	220	525	50 - 60	1 - 1,15
112/8	230	220	230	50 - 60	1 - 1,15
132/2	400	127	690	50 - 60	1 - 1,15
132/4	400	208	600	50 - 60	1 - 1,15
132/6	400	127	500	50 - 60	1 - 1,15
132/8	400	230	400	50 - 60	1 - 1,15
160/2	400	127	600	50 - 60	1 - 1,15
160/4	400	127	575	50 - 60	1 - 1,15
160/6	400	220	575	50 - 60	1 - 1,15
160/8	400	380	480	50 - 60	1 - 1,15
180/2	400	220	480	50 - 60	1 - 1,15
180/4	400	220	600	50 - 60	1 - 1,15
180/6	400	220	500	50 - 60	1 - 1,15
180/8	400	400	400	50 - 60	1 - 1,15
200/2	400	220	690	50 - 60	1 - 1,15
200/4	400	230	600	50 - 60	1 - 1,15
200/6	400	220	480	50 - 60	1 - 1,15
200/8	400	400	400	50 - 60	1 - 1,15
225/2	400	380	480	50 - 60	1 - 1,15
225/4	400	230	690	50 - 60	1 - 1,15
225/6	400	230	500	50 - 60	1 - 1,15
225/8	400	230	500	50 - 60	1 - 1,15
250/2	400	380	525	50 - 60	1 - 1,15
250/4	400	220	525	50 - 60	1 - 1,15
250/6	400	380	480	50 - 60	1 - 1,15
250/8	400	230	440	50 - 60	1 - 1,15
280/2	400	220	600	50 - 60	1 - 1,15
280/4	400	220	600	50 - 60	1 - 1,15
280/6	400	230	480	50 - 60	1 - 1,15
280/8	400	400	500	50 - 60	1 - 1,15
315/2	400	220	525	50 - 60	1 - 1,15
315/4	400	220	550	50 - 60	1 - 1,15
315/6	400	347	550	50 - 60	1 - 1,15
315/8	400	380	500	50 - 60	1 - 1,15
355/2	400	240	660	50 - 60	1 - 1,15
355/4	400	380	500	50 - 60	1 - 1,15
355/6	400	380	500	50 - 60	1 - 1,15
355/8	400	220	440	50 - 60	1 - 1,15
400/2	400	400	690	50 - 60	1 - 1,15
400/4	400	380	690	50 - 60	1 - 1,15
400/6	400	400	690	50 - 60	1 - 1,15
400/8	400	400	690	50 - 60	1 - 1,15
450/4	400	400	690	50 - 60	1 - 1,15
450/6	400	400	400	50 - 60	1 - 1,15

Allowable Mechanical Dimensions for Special Shaft Requests

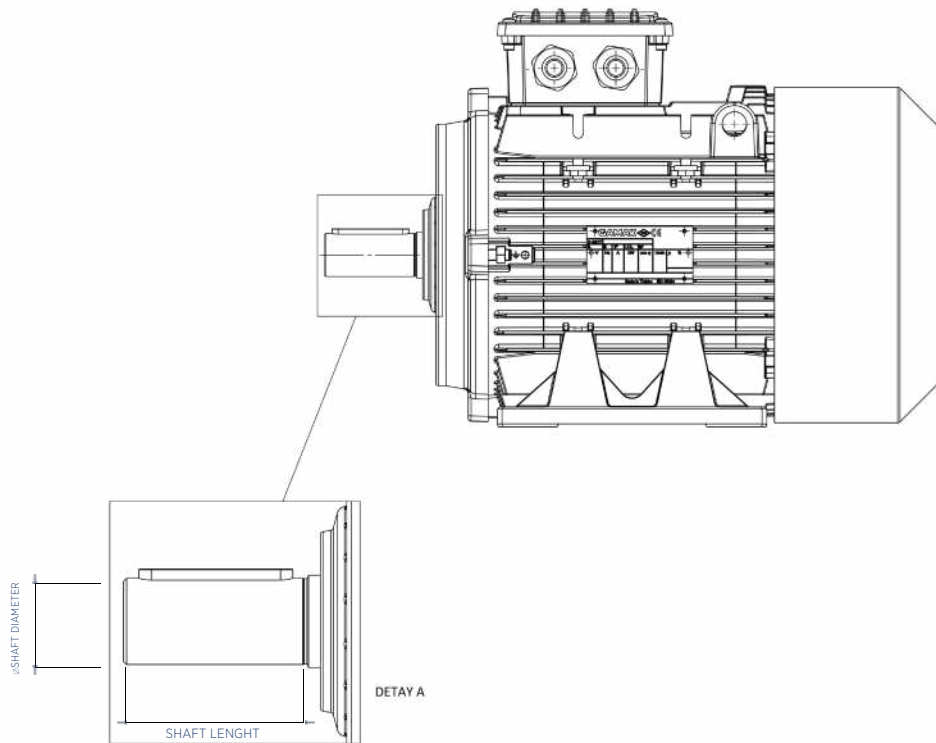

Type/Pole	Standard Shaft Diameter	Min. Shaft Diameter	Max. Shaft Diameter	Bearing Seat Diameter	Standard Shaft Length	Max. Shaft Length
63	11	11	11	12	23	23
71	14	13	14	15	30	30
80	19	17	19	20	40	40
90	24	19	24	25	50	80
100	28	23	28	30	60	100
112	28	24	28	30	60	100
132	38	31	38	40	80	150
160	42	40	44	45	110	110
180	48	44	49	50	110	110
200	55	50	59	60	110	140
225-2	55	45	64	65	110	200
225-4-6-8	60	55	64	65	140	180
250-2	60	52	74	75	140	220
250-4-6-8	65	60	74	75	140	180
280-2	65	53	74	75	140	250
280-4-6-8	75	65	79	80	140	220
315-2	65	58	79	80	140	220
315-4-6-8	85	75	89	90	170	240
355-2	80	68	89	90	170	350
355-4-6-8	100	90	104	105	210	260
400-2	80	70	89	90	170	310
400-4-6-8	110	100	119	120	210	330
450-4-6-8	120	108	129	130	210	350

NOTES:

1. Shaft diameter and shaft length cannot change at the same time.
2. The min. shaft diameter indicated in the table can be given with standard length and max. shaft length can be given with standard diameter.
3. These values are valid only for standard ball bearing design motors.
4. Max. shaft diameter must be smaller than the diameter of the bearing location.
5. Please consult for any application other than the values specified in the table.
6. All our dimensions are in mm.



SINGLE PHASE ASYNCHRONOUS MOTORS



Standard
Series





SINGLE-PHASE MOTORS

Single-phase motors mechanically comply with the same standards as 3-phase motors. In single-phase motors, the rotating field that creates the motor torque is created with the help of 2 separate windings called main and auxiliary windings. Depending on the application, these motors can be selected with permanent capacitor or start + permanent circuit capacitor. Both types of motors have the following benefits and limitations.

Single Phase Motor Features		
Power Range	0,12-3 kW	 Provides up to 84.5% energy efficiency with IE2 efficiency class.
Pole	2-4	
Efficiency	IE2	
Frame Sizes	71-80-90-100	 Lower temperature during operation with IE2 efficiency class while providing a long service life.
Frame Material	Aluminum	
Protection Class	IP55	 It has standard operating values of 220V-230V 50 Hz.
Insulation Class	F (155° C)	
Heat Rise Class	B (80K)	
Terminal Box	Plastic	
Cooling Method	TEFC- IC411	
Installation arrangements	B3,B5,B14,B34,B35	

Permanent Circuit Capacitor Design (M22D)

In this type of single-phase motor, the permanent circuit capacitor, which is in circuit during operation, is connected in series with the auxiliary winding. The power factor is high. Single-phase motors with permanent circuit capacitors, which have a starting torque between 50-80% of the Rated torque, are especially used in applications that do not require high starting torque such as circular saws, drill machines, polishing machines, lawn mowers, pumps and fans.

Start + Permanent Circuit Capacitor Design (MS22D-MK22D)

This type of single-phase motors have a start capacitor placed in the terminal box, which is activated for a short time and a permanent circuit capacitor that is constantly activated. Electronic relay or centrifugal switches are designed to deactivate the start capacitor. When motors with start + permanent circuit capacitors reach approximately 70-75% of their rated speed, they disable the start capacitor with the help of a relay or centrifugal switch and continue to operate like a permanent capacitor motor. They are used in applications where high starting torque is required, such as compressors, hydraulic pumps, centrifugal pumps and industrial kitchen equipment.



M22D
 Permanent
 Circuit
 Capacitor
 Design





MK22D
 Start+
 Permanent
 Circuit Capacitor
 Design / Centrifugal
 Switch

MS22D
 Start+
 Permanent
 Circuit Capacitor
 Design / Electronic
 Relay

Electronic Relay

The main and auxiliary winding terminals of motors with Start + Permanent Circuit Capacitor and the ends of the start capacitor connected in parallel to the permanent circuit capacitor and the permanent circuit capacitor are connected to the terminals of the electronic start relay and the motor starts to work with a high starting torque when voltage is applied to the supply terminals. When the motor reaches approximately 70-75% of its rated speed, it reaches sufficient torque to lift the counter load. At this point, the electronic start relay controls the voltage on the auxiliary winding and deactivates the start capacitor and the motor continues to run with a single capacitor, just as in the permanent capacitor design. If the motor fails to start within 3 seconds for any reason, the start capacitor is deactivated by means of a safety timer integrated into the electronic start relay, thus protecting the start capacitor against burnout and the auxiliary winding against overload during lock-up. The electronic start-up relay is designed to operate in 220-240V 50/60 Hz single-phase networks and is protected against excessive start-up currents and network harmonics that may occur in different applications. In case the motor operates at non-standard voltage, please consult us about the suitable relay.

-  For the durability of the electrolytic start circuit capacitor, the motor is not allowed more than 3 starts per minute. More than one take-off should be avoided. Also, sufficient time must have elapsed between two starts for the motor shaft to stop.
-  Discharge resistors are connected in parallel to the capacitors in order to discharge the voltage generated on the startup circuit capacitors, please contact our company for capacity and resistance values when the capacitors need to be replaced.

Centrifugal Switch

It is a switch that moves with the centrifugal force generated as a result of the rotational movement on the shaft. While both capacitors are activated at start, when the motor reaches a certain speed, it deactivates the start capacitor. In applications where single-phase motors are overloaded, as the centrifugal force decreases with the motor speed, the contacts of the centrifugal switch close and re-activate the start capacitor, while in electronic start relay, the start capacitor cannot be reactivated without de-energizing the motor.



**POWER
TO
ENERGIZE
LIFE**

Allowable Mechanical Forces

Allowable radial forces (Axial force $F_a = 0$)

Frame Size	3000 RPM		1500 RPM	
	F_{X0} (N)	$F_{X_{max}}$ (N)	F_{X0} (N)	$F_{X_{max}}$ (N)
71	400	340	500	420
80	660	540	840	680
90	730	600	910	720
100	1030	820	1300	1050

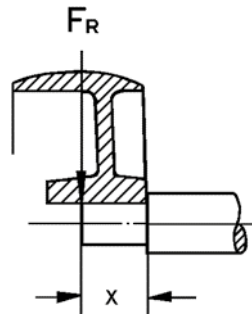

Allowable Axial External Forces

Frame Size	Horizontal Shaft				Vertical Shaft											
	Pulling	Pushing			Shaft / Down						Shaft / Up					
		$F_r=0$	max. F_r		$F_r=0$	Force Down			Force Up			Force Down			Force Up	
		$X_{0'}da$	$X_{max'}da$		$X_{0'}da$	$X_{max'}da$	$F_r=0$	$X_{0'}da$	$X_{max'}da$		$X_{0'}da$	$X_{max'}da$	$F_r=0$	$X_{0'}da$	$X_{max'}da$	$F_r=0$
N	N	N	N	N	N	N	N	N	N	N	N	N	N	N	N	N

2 poles - 3000 RPM

71	100	190	160	230	90	90	90	190	170	250	170	140	220	110	110	110
80	140	320	270	400	120	120	120	340	290	430	300	240	390	160	160	160
90	160	350	290	430	130	130	130	370	320	470	310	250	400	190	190	190
100	220	490	400	590	170	170	170	520	440	650	420	330	540	270	270	270

4 poles -1500 RPM

71	100	280	250	350	90	90	90	290	260	370	260	220	340	120	120	120
80	140	490	420	610	120	120	120	510	440	640	460	390	590	170	170	170
90	160	530	440	650	120	120	120	570	480	700	480	400	610	200	200	200
100	220	740	630	880	150	170	170	790	670	960	650	540	830	290	290	290

Frame, Bearing, End-Shields and Flanges

Frame size 71 - 80 - 90 - 100 : The frame, End-Shields and flanges of the motors are high pressure die-cast from corrosion resistant aluminum alloy.

Enclosure Protection Degrees

GAMAK motors are manufactured in a fully enclosed structure in accordance with IP 55 degree of protection in order to operate in dusty and humid environments, IP 56, IP65 and IP66 degree of protection can be manufactured upon request.

Terminal Box

The end terminal box comply with IP 65 degree of protection and are located on the top of the motor so that the mains cable entry can be easily made from both sides. The electronic start relay and centrifugal switch, the start circuit capacitor and the permanent circuit capacitor are located in the motor terminal box and their connection patterns are shown in a diagram on the End-Shields of the terminal box.

Shaft End

In our standard production, the shaft end of the motors is single-sided and a suitable key is installed (IEC 60072-1). The shaft end is also threaded in accordance with DIN 332 form D. On request, motors can be manufactured with shaft end on both sides (Except MK22D). The runout of the shaft end, the concentricity of the flange bill and the perpendicularity of its surface are within the normal class limits specified in IEC 60072-1.

Vibration

The dynamic balancing of the rotors of our standard motors is made in accordance with the “normal” mechanical vibration class, complete with a half key placed at the shaft end.

Paint

M22D - MS22D - MK22D motors are painted with RAL 7031 (DIN 1843) gray protective paint, on request a special exterior paint resistant to extremely humid atmosphere, chemicals and microorganisms is applied.

Storage

If the motors are to be stored for a long period of time, they should be kept in clean, well ventilated places without moisture and vibration and their insulation resistance should be measured and the windings should be dried if necessary before commissioning.

Bearings

The motors use high quality, noise-controlled, lifetime lubricated by the manufacturer, sealed on both sides (ZZ) single row deep groove ball bearings.

Where required by the application, in order to prevent the shaft from moving in the axial direction, M22D and MS22D motors can be manufactured on request with a fixed bearing arrangement as follows.

Tip	Front	Rear	MKD / MSD Cable Gland	MD Cable Grand
71	6202 ZZ		M16	M20
80	6204 ZZ	6202 ZZ	M16	M20
90	6205 ZZ		M16	M16
100	6206 ZZ		M16	M20

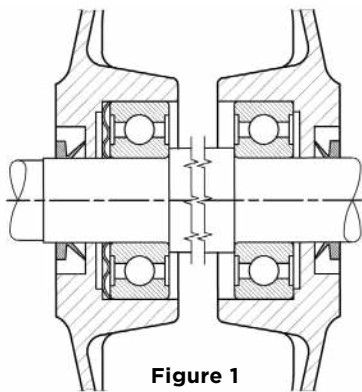

Figure 1
(Standard)

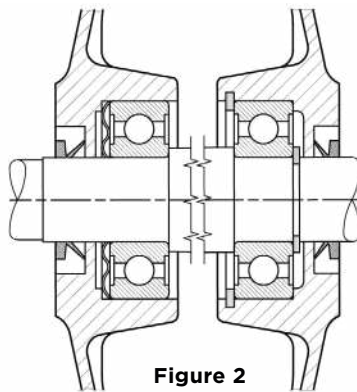

Figure 2
(On Request)

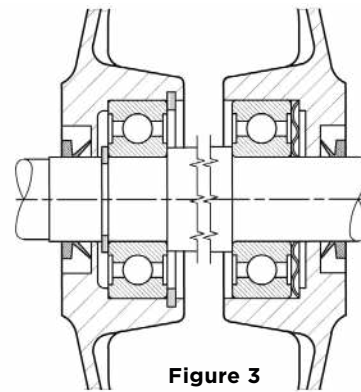

Figure 3
(On Request)

Front	Rear	Front	Rear	Front	Rear
Free Bearing (Spring tensioned)	Free Bearing	Free Bearing (Spring tensioned)	Fixed Bearing	Fixed Bearing	Free Bearing (Spring tensioned)

Voltage and Frequency

Single phase motors are manufactured according to 220-230 V rated voltage and 50 Hz. frequencies as standard. Upon request, 110 V, 240 V mains voltages and 60 Hz. frequency can be manufactured accordingly. Changes of $\pm 5\%$ in rated voltage and frequency practically do not cause any change in motor power. The temperature of motors operating continuously at the upper and lower limits of the allowable voltage variation may exceed the allowable temperature rise limit by a maximum of 10K according to the winding insulation class.

Rated Power

The Rated power P_N is the mechanical power given at the shaft of the motor at the rated values indicated on the nameplate of the motor. The effective power P_1 is the power that the motor draws from the mains and is greater than the mechanical power given by the shaft due to losses.

$$P_1 (W) = U \cdot I \cdot \cos \varphi$$

Efficiency η is the mechanical power divided by the effective power. The efficiency values given in the catalog are calculated by direct measurement method according to IEC 60034-2-1;2024. The rated powers given in this catalog are the mechanical power given by the motor on the shaft at rated voltage and frequency, at 40°C ambient temperature, at altitudes up to 1000 m above sea level and in continuous operation (S1).

Rated Moment

Moment taken from the motor shaft:

$$\text{Rated Moment (Nm)} = 9550 \frac{\text{Rated Power (kW)}}{\text{Rated Speed RPM}}$$

In starting, the motor torque must always be higher than the counter torque of the machine being started.

⚡ Since the rotating field in single-phase motors is generated using only one phase of the mains supply, they produce a lower starting torque compared to three-phase motors. Their vibration and noise levels are also higher than those of three-phase motors. Therefore, in cases where single-phase motors need to be used instead of three-phase motors, please contact our company.

Changing Direction of Rotation

Single-phase motors, like 3-phase motors, are suitable for operation in both directions of rotation. The direction of rotation of motors with permanent capacitors is changed according to the following connection diagram.

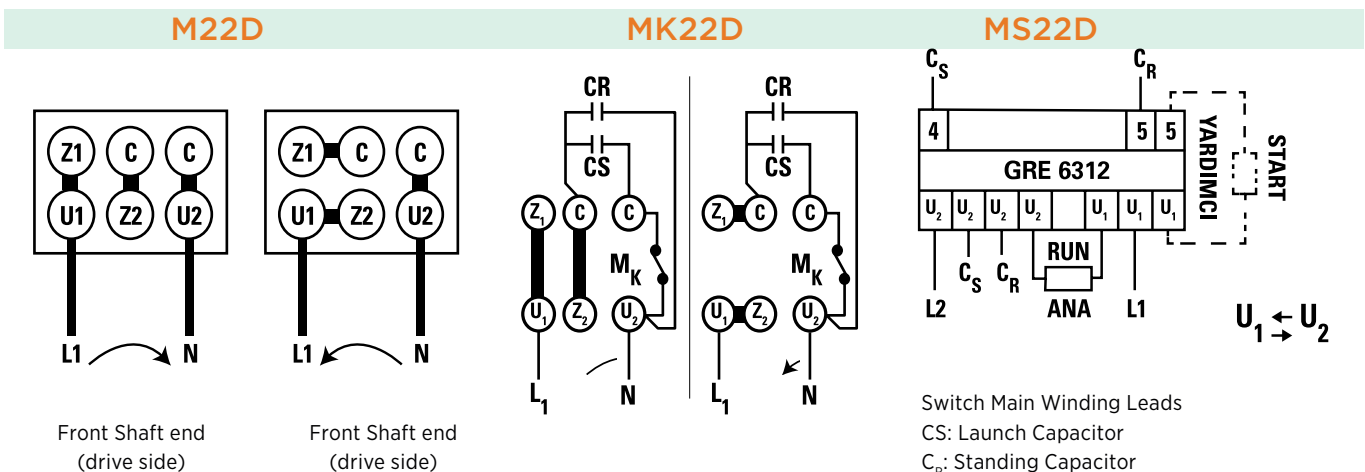

Rotation direction of MK22D motors is changed according to MK22D connection diagram. In motors with start + permanent capacitor, the motor rotation direction is changed by changing the main winding ends of the electronic start relay. Before connecting the motors to the counter machine, the direction of rotation should be checked by making a quick on/off once.

Idle Operation

The voltage value on the capacitors used in single-phase motors reaches the highest value in no-load operation and thus the capacitor life is shortened, in addition, single-phase motors should not be operated idle for a long time since the losses in idle operation are higher than full load operation. Please contact our company as special winding design may be required for the application in cases where long-term idle operation is required.

SINGLE PHASE MOTORS / SPARE PARTS

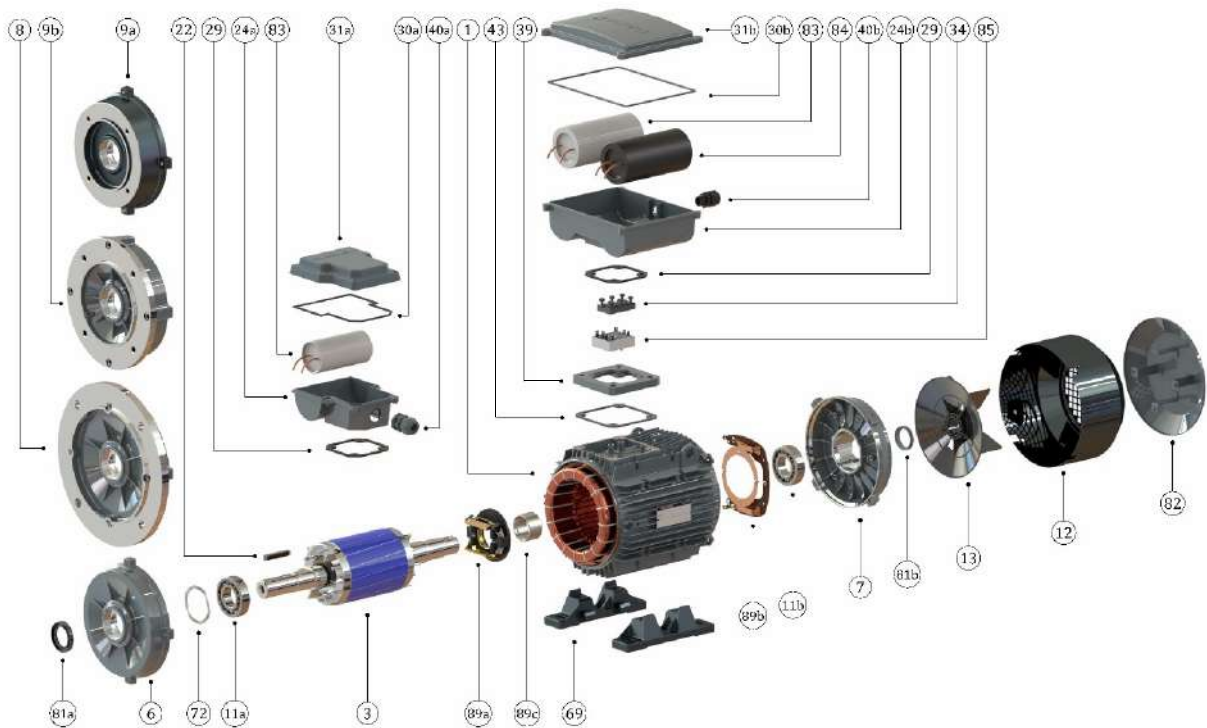

- | | |
|-------|--|
| 1 | Stator with complete windings: Varnished and installed to the body |
| 3 | Complete rotor: With balanced, shaft, machined (excluding keys). |
| 6 | Drive-End Endshield |
| 7 | Non-Drive End Endshield |
| 8 | Flange (Form A - "FF"): B5 |
| 9a | Flange (Form C - "FT"): B14 |
| 9b | Flange (Form C - "FT", Large type): B14/2 |
| 11a | Drive End Bearing |
| 11b | Non-Drive End Bearing |
| 12 | Fan End-Shields |
| 13 | Cooling fan |
| 22 | Shaft and key |
| 24a | End terminal box - Permanent circuit capacitor design (M22D) |
| 24b | End terminal box - Start-up+permanent circuit capacitor design (M22D) (MS22D - MK22D) |
| 29 | Seal- Between end terminal box and motor frame |
| 30a | Seal- (Between end terminal box and End-Shields) Permanent circuit capacitor design |
| 30b | Seal- (Between end terminal box and End-Shields) Start-Up+Permanent circuit capacitor design |
| 31a | End Terminal Box End-Shields-Permanent circuit capacitor design |
| 31b | End Terminal Box End-Shields-Start-Up+Permanent circuit capacitor design |
| 34 | Connector |
| 39 | The intermediate connection part (100 frame) |
| 40a&b | Cable entry gland |
| 43 | Seal-Between end terminal box and motor frame (100 frame) |
| 69 | Foot mounted |
| 72 | Disc spring |
| 81a | Oil seal |
| 81b | Rubber dust seal (V-ring) |
| 82 | Canopi |
| 83 | Permanent circuit capacitor |
| 84 | Start+up capacitor |
| 85 | Electronic start+up relay (Start-up+Permanent circuit capacitor motors) |
| 89a | Centrifugal switch |
| 89b | Centrifugal contact |
| 89c | Centrifugal switch ring |

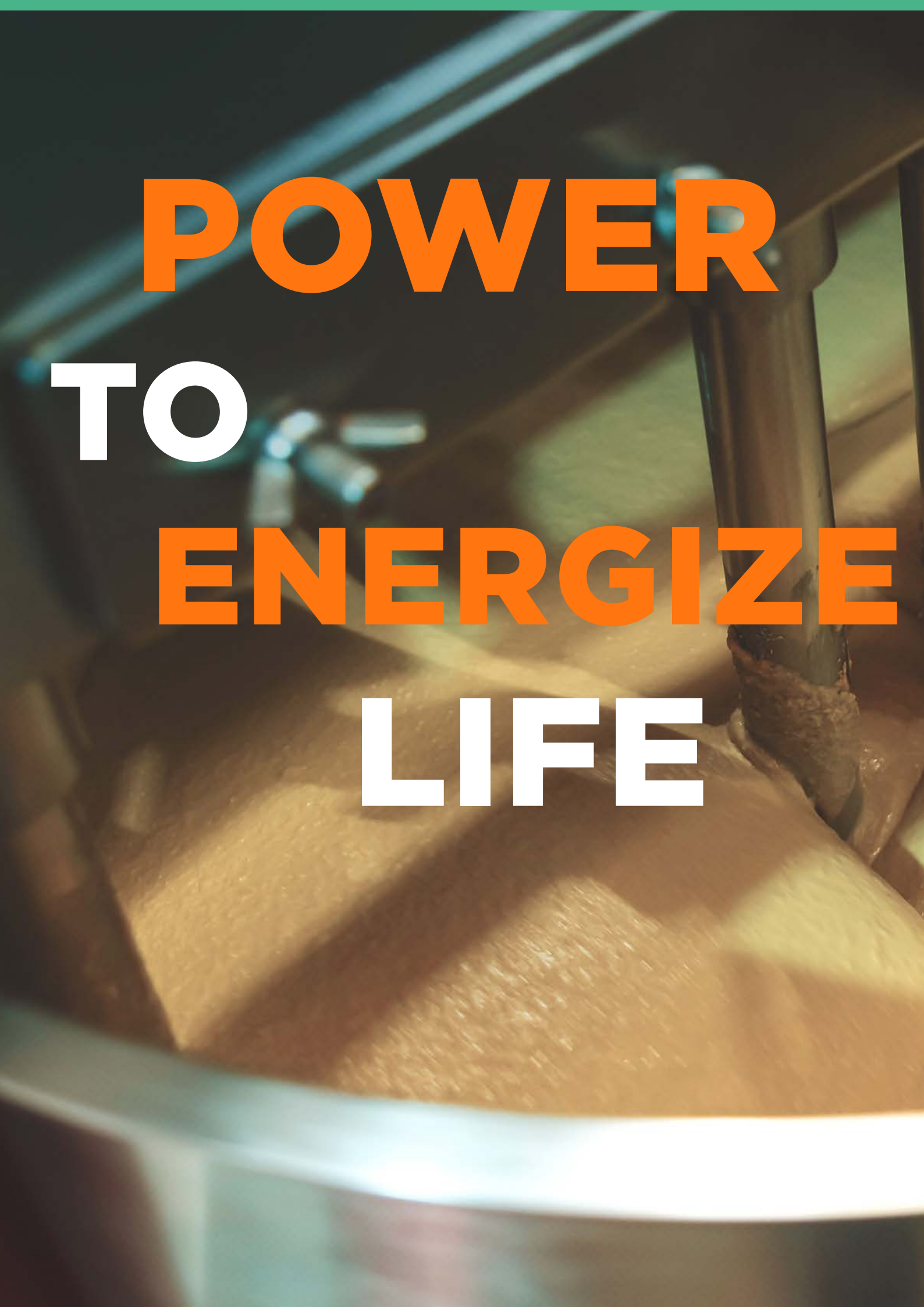

POWER
TO
ENERGIZE
LIFE

A close-up photograph of a dough mixer's motor and mixing bowl. The motor is a dark, cylindrical component on the left, partially obscured by the bowl. The bowl is filled with a thick, yellowish dough that is being mixed. The dough has a smooth, slightly glossy texture. The lighting is warm and focused on the dough, creating a sense of depth and texture. The background is dark and out of focus.

The motor of
these dough
mixing machines
**has a familiar
signature.**

M22D 1 Phase, 220-230 V, 50 Hz, IE2



Duty Type
S1 (Continuous Operation)



Insulation Class
F (155°C)



Protection Class
IP 55



Temperature Rise
B (80 K)



PERMANENT CIRCUIT CAPACITOR MOTORS

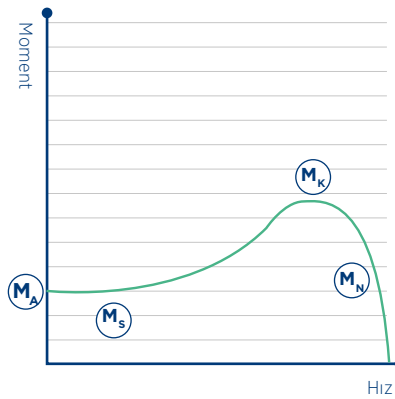
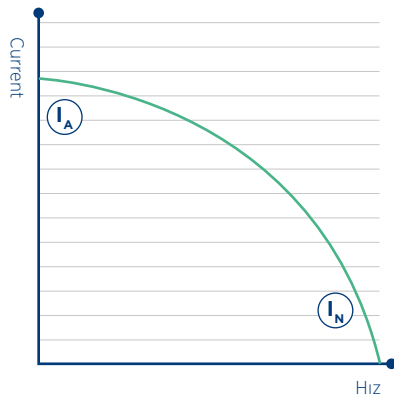

Rated Power	Type	At Rated Power					At Starting		Breakdown Torque Ratio	Permanent Circuit Capacitor μF	Moment of Inertia J	Approx Weight B3
		Speed	Current I_N	Torque M_n	Power Coefficient	Efficiency η	Current Ratio	Torque Ratio				
kW		RPM	A	Nm	$\text{Cos } \phi$	%	I_A / I_N	M_A / M_N	M_k / M_N	kgm^2	kg	

2 poles - 3000 RPM

0,18	M22D 71 M 2a	2855	1,4	0,60	0,97	60,4	3,3	0,41	1,84	10	0,00022	4,9
0,25	M22D 71 M 2b	2760	1,95	0,86	0,90	64,8	2,5	0,43	1,50	15	0,00025	5,5
0,37	M22D 71 M 2c	2800	2,6	1,26	0,93	69,5	2,5	0,50	1,60	20	0,00028	6
0,55	M22D 71 M 2d	2810	3,4	1,86	0,99	74,1	3,0	0,60	1,86	25	0,00031	6,6
0,37	M22D 80 M 2a	2860	2,4	1,23	0,99	69,5	3,0	0,51	1,63	20	0,00034	7,3
0,55	M22D 80 M 2b	2850	3,4	1,84	0,99	74,1	3,5	0,49	1,86	25	0,00043	8,7
0,75	M22D 80 M 2c	2850	4,3	2,50	0,99	77,4	4,0	0,46	1,80	30	0,00056	9,6
1,1	M22D 80 M 2d	2845	6,4	3,69	0,98	79,7	4,0	0,45	1,80	40	0,00070	10,7

4 poles - 1500 RPM

0,12	M22D 71 M 4a	1440	0,93	0,80	0,99	59,1	3,0	0,38	2,10	8	0,00035	5,1
0,18	M22D 71 M 4b	1410	1,3	1,22	0,97	64,7	3,0	0,42	1,80	10	0,00039	5,4
0,25	M22D 71 M 4c	1395	1,83	1,71	0,91	68,5	3,5	0,48	2,10	20	0,00048	5,96
0,37	M22D 71 M 4d	1385	2,45	2,55	0,95	72,7	3,0	0,41	1,90	15	0,00056	7,1
0,37	M22D 80 M 4a	1380	2,4	2,55	0,96	72,7	3,0	0,5	1,70	20	0,00071	8,6
0,55	M22D 80 M 4b	1405	3,4	3,76	0,95	77,1	3,5	0,54	1,80	30	0,00092	9,4
0,75	M22D 80 H 4c	1420	4,5	5,10	0,95	79,6	4,0	0,40	1,42	40	0,00092	9,4

MS22D 1 Phase, 220-230 V, 50 Hz, IE2



Duty Type
S1 (Continuous Operation)



Insulation Class
F (155°C)



Protection Class
IP 55



Temperature Rise
B (80 K)



START + PERMANENT CAPACITOR MOTORS / ELECTRONIC RELAY

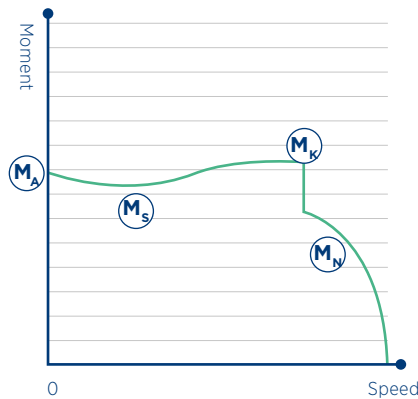
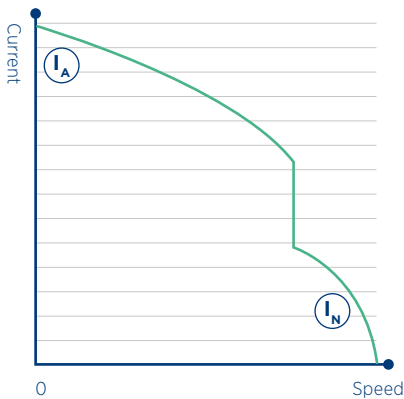

Rated Power	Type	At Rated Power					At Starting		Breakdown Torque Ratio	Start-up Capacitor	Permanent Circuit Capacitor	Moment of Inertia	Approx Weight
		Speed	Current I_N	Torque M_n	Power Coefficient	Efficiency η	Current Ratio	Torque Ratio					
kW		RPM	A	Nm	Cos ϕ	%	I_A / I_N	M_A / M_N	MK / MN	μF	μF	J	B3

2 poles - 3000 RPM

0,18	MS22D 71 M 2a	2855	1,4	0,60	0,97	60,40	4,5	2,1	1,84	108-130	10	0,00022	4,9
0,25	MS22D 71 M 2b	2760	2,0	0,86	0,90	64,80	4,0	2,0	1,50	108-130	15	0,00025	5,5
0,37	MS22D 71 M 2c	2800	2,6	1,26	0,93	69,50	4,0	2,0	1,60	53-64	20	0,00028	6
0,55	MS22D 71 M 2d	2810	3,4	1,86	0,99	74,10	5,0	1,8	1,86	108-130	25	0,00031	6,6
0,37	MS22D 80 M 2a	2860	2,4	1,23	0,99	69,50	4,2	2,0	1,63	88-106	20	0,00034	7,3
0,55	MS22D 80 M 2b	2850	3,4	1,84	0,99	74,10	4,5	2,0	1,86	145-174	25	0,00043	8,7
0,75	MS22D 80 M 2c	2850	4,3	2,50	0,99	77,40	5,0	1,8	1,80	161-193	30	0,00056	9,6
1,1	MS22D 80 M 2d	2820	6,4	3,72	0,98	79,70	4,0	1,6	1,46	161-193	40	0,00070	10,7
0,75	MS22D 90 S 2a	2890	4,5	2,49	0,98	77,40	4,0	1,8	1,60	233-280	40	0,00120	11,5
1,1	MS22D 90 S 2b	2880	6,8	3,65	0,93	79,60	4,5	1,8	1,71	288-331	50	0,00170	15
1,5	MS22D 90 S 2c	2860	8,8	5,00	0,96	81,30	4,0	1,8	1,51	430-516	70	0,00140	13,5
1,8	MS22D 90 L 2d	2875	10,2	5,98	0,97	82,20	5,0	1,8	1,60	460-552	80	0,0020	16
2,2	MS22D 90 L 2e	2865	13,0	7,30	0,93	83,20	4,5	1,8	1,64	460-552	100	0,0027	16
3	MS22D 100 L 2a	2930	16,1	9,76	0,99	84,60	6,0	1,8	2,21	460-552	70	0,00310	22

MS22D 1 Phase, 220-230 V, 50 Hz, IE2



Duty Type
S1 (Continuous Operation)



Protection Class
IP 55



Insulation Class
F (155°C)



Temperature Rise
B (80 K)



START + PERMANENT CAPACITOR MOTORS WITH ELECTRONIC RELAY

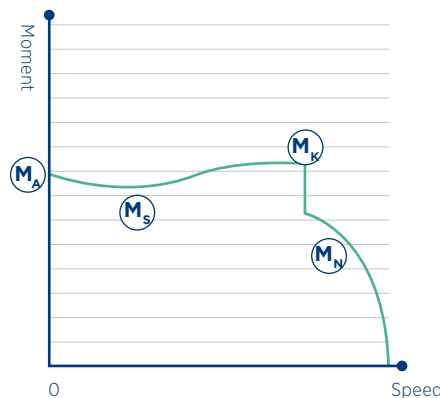
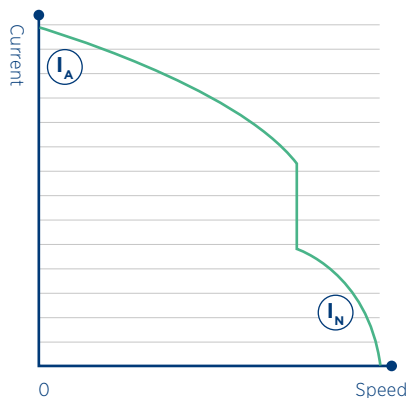

Rated Power	Type	At Rated Power					At Starting		Breakdown Torque Ratio	Start-up Capacitor	Permanent Circuit Capacitor	Moment of Inertia	Approx Weight
		Speed	Current I _N	Torque M _n	Power Coefficient	Efficiency η	Current Ratio	Torque Ratio					
kW		RPM	A	Nm	cos φ	%	I _A / I _N	M _A / M _N	M _K / M _N	μF	μF	J	B3

4 poles - 1500 RPM

0,12	MS22D 71 M 4a	1440	0,93	0,80	0,99	59,10	4,5	1,5	1,64	36-43	8	0,00035	5,1
0,18	MS22D 71 M 4b	1410	1,3	1,22	0,97	64,70	3,8	1,8	1,41	36-43	10	0,00039	5,4
0,25	MS22D 71 M 4c	1395	1,83	1,71	0,91	68,50	6,0	2,0	1,50	36-43	20	0,00048	5,96
0,37	MS22D 71 M 4d	1385	2,45	2,55	0,95	72,70	4,0	2	1,31	53-64	15	0,00056	7,1
0,37	MS22D 80 M 4a	1380	2,4	2,55	0,96	72,70	4,0	1,8	1,31	161-193	20	0,00071	8,6
0,55	MS22D 80 M 4b	1405	3,4	3,76	0,95	77,10	4,5	2,2	1,54	161-193	30	0,00092	9,4
0,55	MS22D 90 S 4a	1435	3,3	3,66	0,99	77,10	4,5	2,1	1,39	233-280	30	0,00250	13,8
0,75	MS22D 90 S 4b	1440	4,4	4,97	0,98	79,60	4,4	2,2	1,47	288-331	35	0,00330	17
1,1	MS22D 90 S 4c	1445	6,3	7,26	0,98	81,40	5,0	2,2	1,62	288-331	40	0,00380	17,8
1,5	MS22D 90 L 4d	1445	8,3	9,90	0,99	82,80	4,5	2,4	1,56	460-522	70	0,00450	18,3
1,8	MS22D 100 L 4a	1440	10,4	11,93	0,94	83,50	4,5	1,8	1,36	430-516	70	0,00520	23
2,2	MS22D 100 L 4b	1450	12,1	14,50	0,98	84,30	4,5	2,0	1,57	430-516	70	0,00680	23
3	MS22D 100 L 4c	1450	16,5	19,80	0,97	85,50	5,5	2,0	1,60	460-552	80	0,00750	23

MK22D | 1 Phase, 220-230 V, 50 Hz, IE2

Duty Type
S1 (Continuous Operation)

Protection Class
IP 55

Insulation Class
F (155°C)

Temperature Rise
B (80 K)



START + PERMANENT CAPACITOR MOTORS / CENTRIFUGAL SWITCH

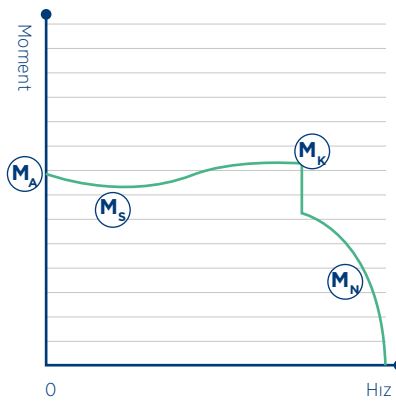
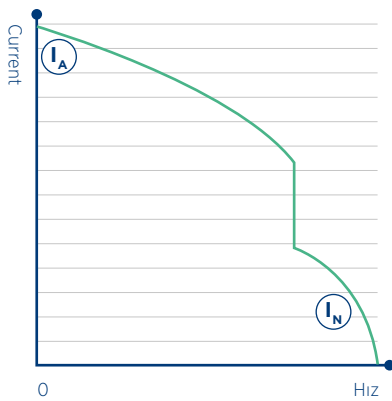

Rated Power kW	Type	At Rated Power					At Starting		Breakdown Torque Ratio MK / MN	Start-up Capacitor μF	Permanent Circuit Capacitor μF	Moment of Inertia J kgm ²	Approx Weight B3 kg
		Speed RPM	Current IN A	Torque Mn Nm	Power Coefficient Cos φ	Efficiency η %	Current Ratio IA / IN	Torque Ratio MA / MN					

2 poles - 3000 RPM

0,18	MK22D 71 M 2a	2855	1,4	0,60	0,97	60,4	4,5	2,1	1,84	108-130	10	0,00022	4,9
0,25	MK22D 71 M 2b	2760	1,95	0,86	0,90	64,8	4,0	2,0	1,50	108-130	15	0,00025	5,5
0,37	MK22D 71 M 2c	2800	2,6	1,26	0,93	69,5	4,0	2,0	1,60	53-64	20	0,00028	6
0,55	MK22D 71 M 2d	2810	3,4	1,86	0,99	74,1	5,0	1,8	1,86	108-130	25	0,00031	6,6
0,37	MK22D 80 M 2a	2860	2,4	1,23	0,99	69,5	4,2	2,0	1,63	88-106	20	0,00034	7,3
0,55	MK22D 80 M 2b	2850	3,4	1,84	0,99	74,1	4,5	2,0	1,86	145-174	25	0,00043	8,7
0,75	MK22D 80 M 2c	2850	4,3	2,50	0,99	77,4	5,0	1,8	1,80	161-193	30	0,00056	9,6
1,1	MK22D 80 M 2d	2820	6,4	3,72	0,98	79,7	4,0	1,6	1,46	161-193	40	0,00070	10,7
0,75	MK22D 90 S 2a	2890	4,5	2,49	0,98	77,4	4,0	1,8	1,60	233-280	40	0,00120	11,5
1,1	MK22D 90 L 2b	2880	6,8	3,65	0,93	79,6	4,5	1,8	1,71	288-331	50	0,00170	15
1,5	MK22D 90 L 2c	2860	8,75	5,00	0,96	81,3	4,0	1,8	1,51	430-516	70	0,00140	13,5
1,8	MK22D 90 H 2d	2875	10,2	5,98	0,97	82,2	5,0	1,8	1,60	460-552	80	0,0020	16
2,2	MK22D 90 H 2e	2865	13	7,30	0,93	83,2	6,5	1,8	1,64	460-552	100	0,0027	16
3	MK22D 100 L 2a	2930	16,1	9,76	0,99	84,6	6,0	1,8	2,21	460-552	70	0,00310	22

MK22D | 1 Phase, 220-230 V, 50 Hz, IE2



Duty Type
S1 (Continuous Operation)



Protection Class
IP 55



Insulation Class
F (155°C)



Temperature Rise
B (80 K)



START + PERMANENT CAPACITOR MOTORS / CENTRIFUGAL SWITCH

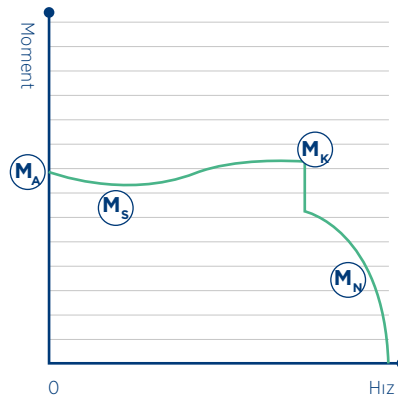
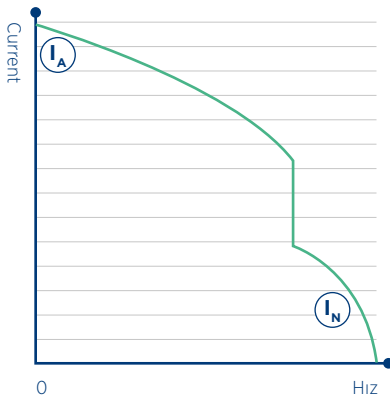

Rated Power	Type	At Rated Power					At Starting		Breakdown Torque Ratio	Start-up Capacitor	Permanent Circuit Capacitor	Moment of Inertia	Approx Weight
		Speed	Current I_N	Torque M_n	Power Coefficient	Efficiency η	Current Ratio	Torque Ratio					
kW		RPM	A	Nm	Cos ϕ	%	I_A / I_N	M_A / M_N	M_K / M_N	μF	μF	J	B3

4 poles - 1500 RPM

0,12	MK22D 71 M 4a	1440	0,93	0,80	0,99	59,1	4,5	1,5	1,64	36-43	8	0,00035	5,1
0,18	MK22D 71 M 4b	1410	1,3	1,22	0,97	64,7	3,8	1,8	1,41	36-43	10	0,00039	5,4
0,25	MK22D 71 M 4c	1395	1,83	1,71	0,91	68,5	6,0	2,0	1,50	36-43	20	0,00048	5,96
0,37	MK22D 71 M 4d	1385	2,45	2,55	0,95	72,7	4,0	2	1,31	53-64	15	0,00056	7,1
0,37	MK22D 80 M 4a	1380	2,4	2,55	0,96	72,7	4,0	1,8	1,31	161-193	20	0,00071	8,6
0,55	MK22D 80 M 4b	1405	3,4	3,76	0,95	77,1	4,5	2,2	1,54	161-193	30	0,00092	9,4
0,75	MK22D 80 H 4c	1420	4,6	5,00	0,93	79,6	4,0	1,8	1,40	130-156	40	0,00092	9,4
0,55	MK22D 90 S 4a	1435	3,3	3,66	0,99	77,1	4,5	2,1	1,39	233-280	30	0,00250	13,8
0,75	MK22D 90 L 4b	1440	4,4	4,97	0,98	79,6	4,4	2,2	1,47	288-331	35	0,00330	17
1,1	MK22D 90 H 4c	1445	6,25	7,26	0,98	81,4	5,0	2,2	1,62	288-331	40	0,00380	17,8
1,5	MK22D 90 H 4d	1445	8,3	9,90	0,99	82,8	4,5	2,4	1,56	460-522	70	0,00450	18,3
1,8	MK22D 100 L 4a	1440	10,4	11,93	0,94	83,5	4,5	1,8	1,36	430-516	70	0,00520	23
2,2	MK22D 100 L 4b	1450	12,1	14,50	0,98	84,3	4,5	2,0	1,57	430-516	70	0,00680	23
3	MK22D 100 H 4c	1450	16,5	19,80	0,97	85,5	5,5	2,0	1,60	460-552	80	0,00800	24,5

SINGLE-PHASE MOTORS / MOTOR DIMENSIONS

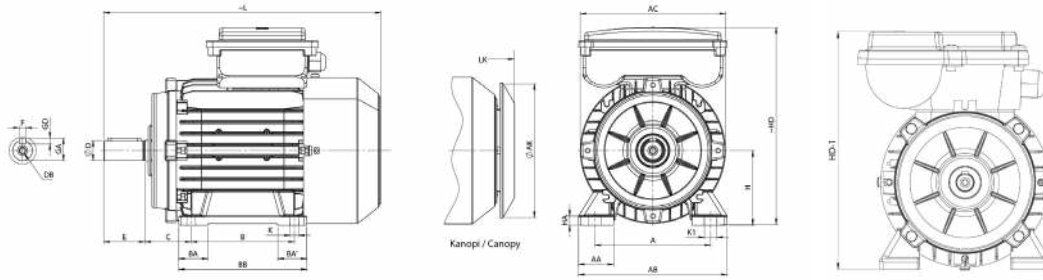

FOOT MOUNTED MOTOR (IEC 60072-1) - B3, B6, B7, B8, V5, V6

Frame Size	H	HD 1	HD 2	HA	A	AA	AB	ACØ	AKØ	K	K1	B	B1	BA	BA1	BB	L	LK	C	E EA	DB DC	DØ DAØ	GA GC	FxGD FAxGF
71	71	194	185	10	112	33	140	138	116	7	11	90	-	27	-	108	259	277	45	30	M5	14	16	5x5
80	80	211	209	10	125	38	160	156	150	10	15	100	-	33	-	125	282	312	50	40	M6	19	21,5	6x6
80 H	80	216	214	10	125	33	160	156	150	10	15	100	-	35	-	125	329	359	50	40	M6	19	21,5	6x6
90 S	90	242	252	12	140	37	180	176	150	10	15	100	-	35	35	130	300	330	56	40	M6	19	21,5	6x6
90 L	90	242	252	12	140	37	180	176	150	10	15	100	125	35	60	155	334	364	56	50	M8	24	27	8x7
90 H	90	242	252	12	140	37	180	176	150	10	15	100	125	35	60	155	360	390	56	50	M8	24	27	8x7
100 L	100	-	280	13	160	39	200	197	188	12	18	140	-	39	39	175	397	437	63	60	M10	28	31	8x7
100 H	100	-	280	13	160	39	200	197	188	12	18	140	-	39	39	175	432	472	63	60	M10	28	31	8x7

*90S 2c - 90S 4c Motors L=310, E=50, DB=M8, ØD=24, GA=27, FxGD=8x7
 *HD 1 dimension belongs to M22D, HD 2 dimension belongs to MK22D and MS22D.
 *B6, B7, B8, V5, V6 installation arrangement do not apply to MK22D.

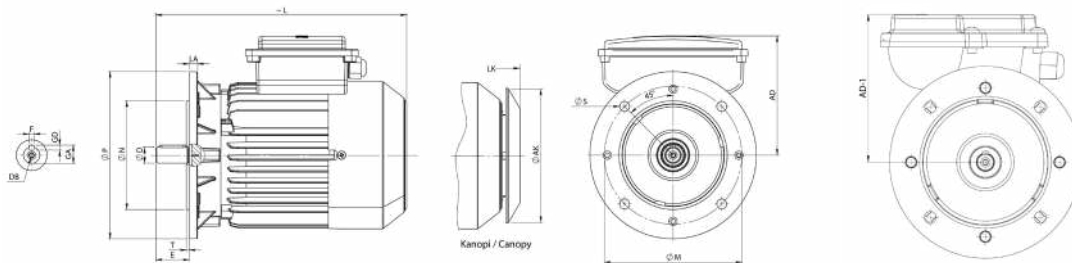

Note: The spindle collar and flange seating surface are in the same plane.

FLANGED MOTOR (TYPE "A" - IEC 60072-1) - B5, V1, V3

Frame Size	Flange No	MØ	NØ	PØ	Fixing Hole		T	LA	AD1	AD2	AKØ	L	LK	E EA	DB DC	DØ DAØ	GA GC	FxGD FAxGF
					No.	SØ												
71	FF130	130	110	160	4	10	3,5	10	123	114	116	259	277	30	M5	14	16	5x5
80	FF165	165	130	200	4	12	3,5	12	131	129	150	282	312	40	M6	19	21,5	6x6
80 H	FF165	165	130	200	4	12	3,5	12	136	134	150	329	359	40	M6	19	22	6x6
90 S	FF165	165	130	200	4	12	3,5	12	152	162	150	300	330	40	M6	19	21,5	6x6
90 L	FF165	165	130	200	4	12	3,5	12	152	162	150	334	364	50	M8	24	27	8x7
90 H	FF165	165	130	200	4	12	3,5	12	152	162	150	360	390	50	M8	24	27	8x7
100 L	FF215	215	180	250	4	14,5	4	15	-	180	188	397	437	60	M10	28	31	8x7
100 H	FF215	215	180	250	4	14,5	4	15	-	180	188	432	472	60	M10	28	31	8x7

*90S 2c - 90S 4c Motors L=310, E=50, DB=M8, ØD=24, GA=27, FxGD=8x7
 *AD 1 dimension belongs to M22D, AD 2 dimension belongs to MK22D and MS22D.
 *V1, V3 installation arrangement are not applicable for MK22D.

All dimensions are in mm.

SINGLE PHASE MOTORS / MOTOR DIMENSIONS

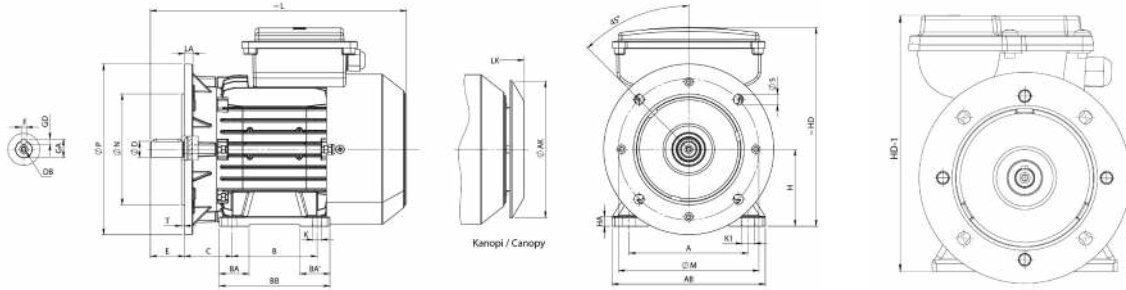

Note: The spindle collar and flange seating surface are in the same plane.

MOTOR WITH FOOT MOUNTED AND FLANGE (TYPE "A" - IEC 60072-1) - B35, V15, V36

Frame Size	H	HD1	HD2	HA	A	AB	ACØ	AKØ	K	K1	B	B'	BA	BA'	BB	Flange No	MØ	NØ	PØ	No	SØ	T	LA	L	LK	C	E	EA	DB	DC	DØ	DAØ	GA	GC	FxGF
71	71	194	185	10	112	140	138	116	7	11	90	-	27	-	108	FF130	130	110	160	4	10	3,5	10	259	278	45	30	M5	14	16	16	16	5x5		
80	80	211	209	10	125	160	156	150	10	15	100	-	33	-	125	FF165	165	130	200	4	12	3,5	12	282	312	50	40	M6	19	21,5	21,5	21,5	6x6		
80 H	80	216	214	10	125	160	156	150	10	15	100	-	33	-	125	FF165	165	130	200	4	12	3,5	12	329	359	50	40	M6	19	21,5	21,5	21,5	6x6		
90 S	90	242	252	12	140	180	176	150	10	15	100	-	35	35	130	FF165	165	130	200	4	12	3,5	12	300	330	56	40	M6	19	21,5	21,5	21,5	6x6		
90 L	90	242	252	12	140	180	176	150	10	15	100	125	35	60	155	FF165	165	130	200	4	12	3,5	12	334	364	56	50	M8	24	27	27	27	8x7		
90 H	90	242	252	12	140	180	176	150	10	15	100	125	35	60	155	FF165	165	130	200	4	12	3,5	12	360	390	56	50	M8	24	27	27	27	8x7		
100 L	100	-	280	13	160	200	197	188	12	18	140	-	39	39	175	FF215	215	180	250	4	14,5	4	15	397	437	63	60	M10	28	31	31	31	8x7		
100 H	100	-	280	13	160	200	197	188	12	18	140	-	39	39	175	FF215	215	180	250	4	14,5	4	15	432	472	63	60	M10	28	31	31	31	8x7		

*90S 2c - 90S 4c Motors L=310, LK=336, E=50, DB=M8, ØD=24, GA=27, FxGD=8x7

*HD 1 size refers to M22D, HD 2 size refers to MK22D and MS22D.

*V15, V36 installation arrangement are not applicable to MK22D.

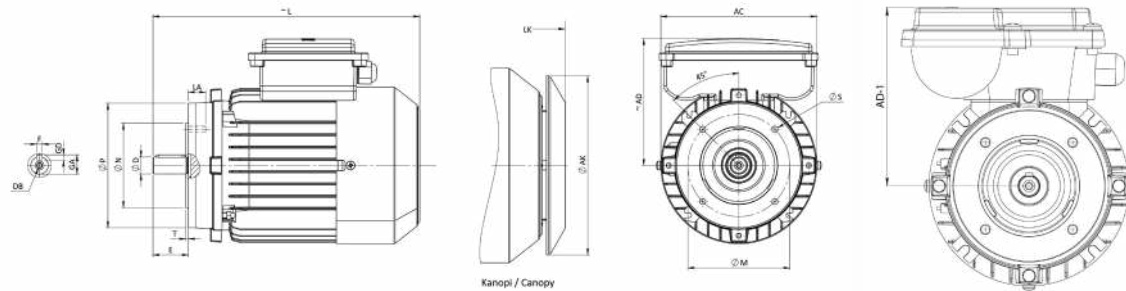

Note: The spindle collar and flange seating surface are in the same plane.

FLANGED MOTOR (TYPE "C"- IEC 60072-1) - B14, V18, V19

Frame Size	Flange No	MØ	NØ	PØ	S	T	LA	ACØ	AKØ	AD1	AD2	L	LK	E	EA	DB	DC	DØ	DAØ	GA	GC	FxGD	FxGF
71	FT85	85	70	105	M6	2,5	12	138	116	123	114	259	278	30	30	M5	14	16	16	16	16	5x5	5x5
80	FT100	100	80	120	M6	3	12	156	150	131	129	282	312	40	40	M6	19	21,5	21,5	21,5	21,5	6x6	6x6
80 H	FT100	100	80	120	M6	3	12	156	150	136	134	329	359	40	40	M6	19	21,5	21,5	21,5	21,5	6x6	6x6
90 S	FT115	115	95	140	M8	3	16	176	150	152	162	300	330	40	40	M6	19	21,5	21,5	21,5	21,5	6x6	6x6
90 L	FT115	115	95	140	M8	3	16	176	150	152	162	334	364	50	50	M8	24	27	27	27	27	8x7	8x7
90 H	FT115	115	95	140	M8	3	16	176	150	152	162	360	390	50	50	M8	24	27	27	27	27	8x7	8x7
100 L	FT130	130	110	160	M8	3,5	16	197	188	-	180	397	437	60	60	M10	28	31	31	31	31	8x7	8x7
100 H	FT130	130	110	160	M8	3,5	16	197	188	-	180	432	472	60	60	M10	28	31	31	31	31	8x7	8x7

*90S 2c - 90S 4c Motors L=310, E=50, DB=M8, ØD=24, GA=27, FxGD=8x7

*AD 1 dimension belongs to M22D, AD 2 dimension belongs to MK22D and MS22D.

*V18, V19 installation arrangement are not valid for MK22D.

All dimensions are in mm.

SINGLE PHASE MOTORS / MOTOR DIMENSIONS

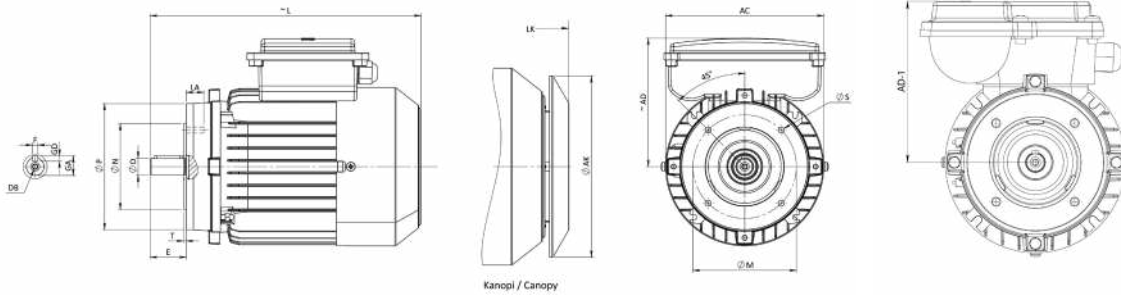

Note: The spindle collar and flange seating surface are in the same plane.

FLANGED MOTOR (TYPE "C" - IEC 60072-1) - B14-2, V18, V19

Frame Size	Flange No	MØ	NØ	PØ	S	T	LA	ACØ	AKØ	AD1	AD2	L	LK	E	EA	DB	DC	DØ	DAØ	GA	GC	FxGD	FAxGF	
71	FT115	115	95	140	M8	3	16	138	116	123	114	259	278	30	M5	14	16	5x5						
80	FT130	130	110	160	M8	3,5	16	156	150	131	129	282	312	40	M6	19	21,5	6x6						
80 H	FT130	130	110	160	M8	3,5	16	156	150	136	134	329	359	40	M6	19	21,5	6x6						
90 S	FT130	130	110	160	M8	3,5	16	176	150	152	162	300	330	40	M6	19	21,5	6x6						
90 L	FT130	130	110	160	M8	3,5	16	176	150	152	162	334	364	50	M8	24	27	8x7						
90 H	FT130	130	110	160	M8	3,5	16	176	150	152	162	360	390	50	M8	24	27	8x7						
100 L	FT165	165	130	200	M10	3,5	20	197	188	-	180	397	437	60	M10	28	31	8x7						
100 H	FT165	165	130	200	M10	3,5	20	197	188	-	180	432	472	60	M10	28	31	8x7						

*90S 2c - 90S 4c Motors L=310, E=50, DB=M8, ØD=24, GA=27, FxGD=8x7
 *AD 1 dimension belongs to M22D, AD 2 dimension belongs to MK22D and MS22D.
 *V18, V19 installation arrangement are not applicable to MK22D.

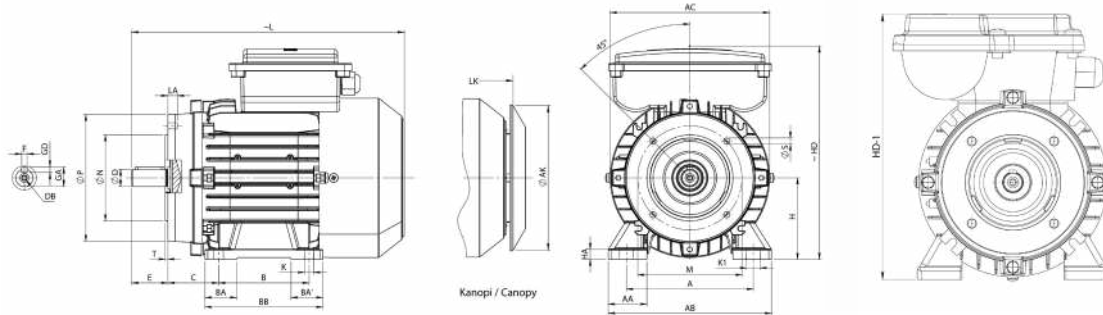

Note: The spindle collar and flange seating surface are in the same plane.

FLANGED MOTOR (TYPE "C" - IEC 60072-1) - B34, V58, V69

Frame Size	H	HD1	HD2	HA	A	AA	AB	ACØ	AKØ	K	K1	B	B'	BA	BA'	BB	Flange No	MØ	NØ	PØ	SØ	T	LA	L	LK	C	E	EA	DB	DC	DØ	DAØ	GA	GC	FxGD	FAxGF
71	71	194	185	10	112	33	140	138	116	7	11	90	-	27	-	108	FT85	85	70	105	M6	2,5	12	259	278	45	30	M5	14	16	5x5					
80	80	211	209	10	125	38	160	156	150	10	15	100	-	33	-	125	FT100	100	80	120	M6	3	12	282	312	50	40	M6	19	21,5	6x6					
80 H	80	216	214	10	125	33	160	156	150	10	15	100	-	35	-	125	FT100	100	80	120	M6	3	12	329	359	50	40	M6	19	21,5	6x6					
90 S	90	242	252	12	140	37	180	176	150	10	15	100	-	35	35	130	FT115	115	95	140	M8	3	16	300	330	56	40	M6	19	21,5	6x6					
90 L	90	242	252	12	140	37	180	176	150	10	15	100	125	35	60	155	FT115	115	95	140	M8	3	16	334	364	56	50	M8	24	27	8x7					
90 H	90	242	252	12	140	37	180	176	150	10	15	100	125	35	60	155	FT115	115	95	140	M8	3	16	360	390	56	50	M8	24	27	8x7					
100 L	100	-	280	13	160	39	200	197	188	12	18	140	-	39	39	175	FT130	130	110	160	M8	3,5	16	397	437	63	60	M10	28	31	8x7					
100 H	100	-	280	13	160	39	200	197	188	12	18	140	-	39	39	175	FT130	130	110	160	M8	3,5	16	432	472	63	60	M10	28	31	8x7					

*90S 2c - 90S 4c Motors L=310, E=50, DB=M8, ØD=24, GA=27, FxGD=8x7
 *HD 1 size refers to M22D, HD 2 size refers to MK22D and MS22D.
 *V58, V69 installation arrangement are not applicable to MK22D.

All dimensions are in mm.

SINGLE-PHASE MOTORS / MOTOR DIMENSIONS

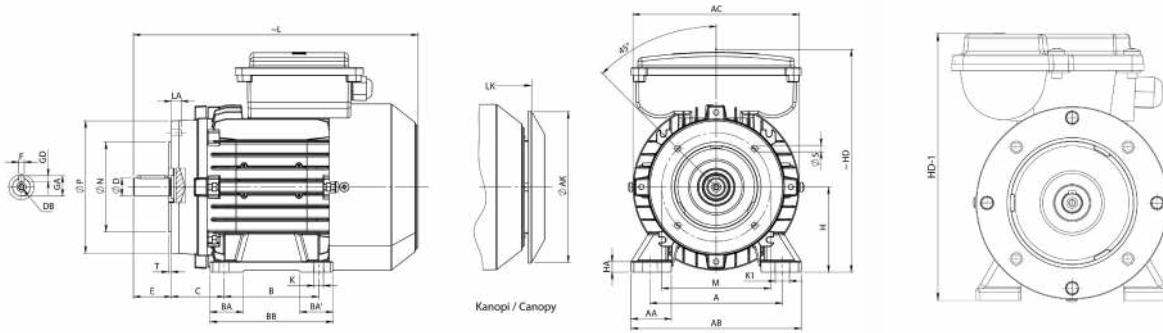

Note: The spindle collar and flange seating surface are in the same plane.

FLANGED MOTOR (TYPE "C" - IEC 60072-1) - B34-2, V58, V69

Frame Size	H	HD1	HD2	HA	A	AA	AB	ACØ	AKØ	K	K1	B	B'	BA	BA'	BB	Flange No	MØ	NØ	PØ	SØ	T	LA	L	LK	C	E EA	DB DC	DØ DAØ	GA GC	FxGD FAxGF
71	71	194	185	10	112	33	140	138	116	7	11	90	-	27	-	108	FT115	115	95	140	M8	3	16	259	278	45	30	M5	14	16	5x5
80	80	211	209	10	125	38	160	156	150	10	15	100	-	33	-	125	FT130	130	110	160	M8	3,5	16	282	312	50	40	M6	19	21,5	6x6
80 H	80	216	214	10	125	33	160	156	150	10	15	100	-	35	-	125	FT100	130	110	160	M8	3,5	16	329	359	50	40	M6	19	21,5	6x6
90 S	90	242	252	12	140	37	180	176	150	10	15	100	-	35	35	130	FT130	130	110	160	M8	3,5	16	300	330	56	40	M6	19	21,5	6x6
90 L	90	242	252	12	140	37	180	176	150	10	15	100	125	35	60	155	FT130	130	110	160	M8	3,5	16	334	364	56	50	M8	24	27	8x7
90 H	90	242	252	12	140	37	180	176	150	10	15	100	125	35	60	155	FT130	130	110	160	M8	3,5	16	360	390	56	50	M8	24	27	8x7
100 L	100	-	280	13	160	39	200	197	188	12	18	140	-	39	39	175	FT165	165	130	200	M10	3,5	20	397	437	63	60	M10	28	31	8x7
100 H	100	-	280	13	160	39	200	197	188	12	18	140	-	39	39	175	FT165	165	130	200	M10	3,5	20	432	472	63	60	M10	28	31	8x7

*HD 1 dimension belongs to M22D, HD 2 dimension belongs to MK22D and MS22D.

*For 90S 2c - 90S 4c Motors L=310, E=50, DB=M8, ØD=24, GA=27, FxGD=8x7

*V58, V69 installation arrangement are not applicable for MK22D.

All dimensions are in mm.

Power for Every Sector

GAMAK SINGLE PHASE ASYNCHRONOUS IE2 MOTORS



THREE PHASE ASYNCHRONOUS MOTORS



Standard
Series





3 PHASE ASYNCHRONOUS MOTORS

GAMAK 3 phase asynchronous motors offer high performance and reliability in a wide range of applications such as pumps, fans, compressors, conveyors, mixers, ventilation and many more. Special design and production support is also provided according to customer needs.

3 Phase Asynchronous Motors Features	
Power Range	0,12-1000 kW
Pole	2,4,6,8 / Double Speed
Efficiency	IE1, IE2, IE3, IE4
Frame Sizes	63-450
Frame Material	Aluminum (63-250) and Cast Iron (132-450)
Protection Class	IP55 (Options on request IP56, IP65, IP66)
Insulation Class	F(155°C), H(180°C)
Cooling Type	IC 411 (Fully enclosed fan cooled)
Installation Arrangement	B3, B5, B14, B34, B35, B14-2, B34-2

GAMAK 3 phase asynchronous motors offer flexible and practical solutions with a wide range of options and create a distinction with their high performance.

Attachable Foot: Our aluminum frame motors have attachable foot. It can be mounted and dismantled in such a way that the terminal box can face in 3 directions between 90-250 frames, and in 71-80 type frames, the terminal box remains on top.

Fixed Foot: The feet in all cast iron frame products are cast together with the frame.

Frame, End-Shields and Flanges: The materials used in the frames, End-Shields and flanges of the motors are given in the table below according to their frame sizes.

Frame Size	Frame Material	End-Shields	Flanges			Attachable Foot	
			B5	B14	B14-2	Aluminum Frame	Cast Iron Frame
63	Aluminum	Aluminum	Aluminum	Aluminum	Aluminum	-	-
71	Aluminum	Aluminum	Aluminum	Aluminum	Aluminum	Available	-
80	Aluminum	Aluminum	Aluminum	Aluminum	Aluminum		-
90	Aluminum	Aluminum	Aluminum	Aluminum	Aluminum		-
100	Aluminum	Aluminum	Aluminum	Aluminum	Aluminum		-
112	Aluminum	Aluminum	Aluminum	Aluminum	Cast Iron		-
132	Aluminum or Cast Iron	Aluminum or Cast Iron	Aluminum or Cast Iron	Cast Iron	Cast Iron		-
160			Cast Iron	-	-		-
180				-	-		-
200				-	-		-
225				-	-		-
250			-	-	-		
280-450	Cast Iron	Cast Iron	-	-	-	-	

3 Phase, 400 V, 50 Hz, IE1



Duty Type
S1 (Continuous Operation)



Protection Class
IP 55



Insulation Class
F (155°C)



Temperature Rise
B (80 K)



Rated Power	Type	At Rated Power						At Starting				Breakdown Torque Ratio	Moment of Inertia	Approx Weight	
		Speed	Current	Torque	Power Coefficient	Efficiency η			Current Ratio		Torque Ratio				
kW		RPM	A	Nm	Cos ϕ	4/4	3/4	1/2	Direct	Y/ Δ	Direct	Y/ Δ			
Aluminum Frame / 2 poles - 3000 RPM															
0,37	AGMEL 71 M 2a	2775	0,9	1,3	0,82	63,9	65,0	63,0	3,8	-	2	-	2,4	0,00027	4,7
0,55	AGMEL 71 M 2b	2790	1,3	1,9	0,80	69,0	77,0	74,9	4,4	-	2,4	-	2,6	0,00034	5,7
0,75	AGMEL 80 M 2a	2815	1,8	2,6	0,81	72,1	76,8	74,0	4,2	-	2,0	-	2,4	0,001	10,4
1,1	AGMEL 80 M 2b	2830	2,6	3,7	0,80	75,0	77,2	74,4	4,4	-	2	-	2,7	0,001	10,4
1,5	AGMEL 90 S 2a	2850	3,4	5	0,82	77,2	78,4	75,3	4,9	-	1,8	-	2,7	0,0038	13,3
2,2	AGMEL 90 L 2b	2860	4,7	7,35	0,85	79,7	82,1	80,3	5,1	-	2,2	-	2,7	0,0020	18,3
3	AGMEL 100 L 2a	2855	5,7	10,03	0,93	81,5	81,5	80	5,1	-	2,3	-	2,5	0,0031	22
4	AGMEL 112 M 2a	2870	7,7	13,3	0,90	83,1	83	82	5,7	1,9	2,2	0,7	2,7	0,0062	18,1
5,5	AGMEL 132 S 2a	2900	10	18,1	0,94	84,7	86,2	85,8	5,6	1,8	2	0,7	2,8	0,015	51
7,5	AGMEL 132 S 2b	2910	13,1	24,6	0,96	86	87,5	87,9	5,8	2	2,2	0,7	2,9	0,015	51
11	AGMEL 160 M 2a	2940	21,8	35,8	0,75	87,6	87,8	87,1	5,5	1,8	1,6	0,5	2,4	0,027	82
15	AGMEL 160 M 2b	2940	27,5	48,8	0,89	88,7	88,7	88	6,3	2,1	1,6	0,5	2,7	0,027	82
18,5	AGMEL 160 L 2c	2950	33,5	59,9	0,89	89,3	89,3	89	7,1	2,4	1,9	0,6	3	0,043	110,3
22	AGMEL 180 M 2a	2955	40,8	71,1	0,87	89,9	89,9	89	7,8	2,7	2,3	0,7	3,5	0,066	122
30	AGMEL 200 L 2a	2960	53	96,7	0,90	90,7	90,7	89,8	7,8	2,6	2,7	0,9	3,1	0,13	142
37	AGMEL 200 L 2b	2960	64,5	119,2	0,91	91,2	91,2	90,3	7,7	2,6	2,8	0,9	3,1	0,15	172
45	AGMEL 225 M 2a	2970	77,9	144,5	0,91	91,7	91,7	90,8	8	2,6	2,4	0,8	2,9	0,23	249
55	AGMEL 250 M 2a	2970	100	176,7	0,86	92,1	92,3	92,0	7,6	2,5	2,6	0,9	2,7	0,32	279

3 Phase, 400 V, 50 Hz, IE1



Duty Type
S1 (Continuous Operation)



Protection Class
IP 55



Insulation Class
F (155°C)



Temperature Rise
B (80 K)



Rated Power	Type	At Rated Power							At Starting				Breakdown Torque Ratio	Moment of Inertia	Approx Weight
		Speed	Current	Torque	Power Coefficient	Efficiency η			Current Ratio		Torque Ratio				
kW		RPM	A	Nm	Cos ϕ	4/4	3/4	1/2	Direct	Y/ Δ	Direct	Y/ Δ			
Aluminum Frame / 4 poles - 1500 RPM															
0,25	AGMEL 71 M 4a	1415	0,78	1,7	0,68	61,5	66,0	59,4	3,3	-	1,6	-	2,1	0,0004	4,9
0,37	AGMEL 71 M 4b	1405	1,04	2,5	0,72	66,0	70,3	64,9	3,5	-	1,6	-	2,1	0,00059	6,3
0,55	AGMEL 80 M 4a	1400	1,6	3,8	0,72	70,0	70,6	65,9	3,5	-	1,7	-	2,1	0,00095	8,3
0,75	AGMEL 80 M 4b	1405	2,1	5,1	0,73	72,1	72,1	67,6	3,6	-	1,7	-	2,1	0,0014	10,9
1,1	AGMEL 90 S 4a	1410	2,6	7,45	0,81	75	78,1	75,7	3,9	-	1,7	-	2,1	0,0038	13,3
1,5	AGMEL 90 L 4b	1410	3,5	10,15	0,80	77,2	80,4	78,7	4,3	-	2	-	2,4	0,0020	18,3
2,2	AGMEL 100 L 4a	1425	4,9	14,75	0,81	79,7	82,9	82	4,6	-	1,7	-	2,3	0,0052	26,3
3	AGMEL 100 L 4b	1430	6,4	20,1	0,83	81,5	84,2	83,5	4,9	-	2,1	-	2,6	0,0057	25,8
4	AGMEL 112 M 4a	1455	8,40	26,3	0,83	83,1	83,1	82	6,6	2,2	2,5	0,8	3,3	0,0106	29,5
5,5	AGMEL 132 S 4a	1440	12	36,5	0,78	84,7	85,7	84,4	4,6	1,5	1,9	0,6	2,4	0,021	38,4
7,5	AGMEL 132 M 4b	1450	15,8	49,5	0,80	86	87,7	87,1	5,1	1,7	2,1	0,7	2,6	0,026	46,5
11	AGMEL 160 M 4a	1455	22,3	72,3	0,81	87,6	88,4	88	5,2	1,7	1,9	0,6	2,4	0,061	86,3
15	AGMEL 160 L 4b	1455	31,2	98,5	0,78	88,7	88,7	88,2	5,4	1,8	2	0,7	2,5	0,082	94
18,5	AGMEL 180 M 4a	1465	34,6	120,8	0,86	89,3	91	90,7	6,2	2,1	2	0,7	2,7	0,177	160
22	AGMEL 180 L 4b	1470	41,4	143,8	0,85	89,9	91,5	90,9	6,5	2,2	2,1	0,7	2,8	0,192	170
30	AGMEL 200 L 4a	1465	57	195,6	0,84	90,7	90,7	89,8	6,5	2,2	2,4	0,8	2,9	0,227	215
37	AGMEL 225 S 4a	1470	73,6	240,4	0,8	91,2	91,2	91	7,2	2,3	3	1	3	0,3	225
45	AGMEL 225 M 4b	1470	85	292,3	0,84	91,7	91,7	90	7,3	2,4	3	1	3	0,36	246
55	AGMEL 250 M 4a	1470	102	357,3	0,85	92,1	92,3	92	6,4	2,3	2,5	0,8	2,6	0,6	280

3 Phase, 400 V, 50 Hz, IE1



Duty Type
S1 (Continuous Operation)



Protection Class
IP 55



Insulation Class
F (155°C)



Temperature Rise
B (80 K)



Rated Power	Type	At Rated Power							At Starting				Breakdown Torque Ratio	Moment of Inertia	Approx Weight
		Speed	Current	Torque	Power Coefficient	Efficiency η			Current Ratio		Torque Ratio				
kW		RPM	A	Nm	Cos ϕ	4/4	3/4	1/2	Direct	Y/ Δ	Direct	Y/ Δ			
Aluminum Frame / 6 poles - 1000 RPM															
0,37	AGMEL 80 M 6a	940	1,2	3,7	0,75	59,7	59,5	59	3,1	-	1,3	-	1,9	0,0019	11,2
0,55	AGMEL 80 M 6b	950	1,7	5,6	0,71	65,8	65,8	64	3,5	-	1,9	-	2,3	0,001	10,4
0,75	AGMEL 90 S 6a	940	2,2	7,6	0,70	70	72,1	67,1	3,4	-	1,6	-	2,1	0,0038	13,3
1,1	AGMEL 90 L 6b	940	3,2	11,2	0,73	72,9	74,7	70,2	3,6	-	1,7	-	2,2	0,0020	18,3
1,5	AGMEL 100 L 6a	920	3,8	15,6	0,76	75,2	77,3	76,5	3,5	-	1,7	-	2,1	0,011	22,8
2,2	AGMEL 112 M 6a	940	5,3	22,4	0,77	77,7	77,7	76	4,1	-	1,9	-	2,2	0,016	30
3	AGMEL 132 S 6a	960	7,1	29,8	0,77	79,7	79,6	78	4,6	1,5	1,8	0,6	2,3	0,019	35
4	AGMEL 132 M 6b	960	9,3	39,8	0,76	81,4	81,3	80	4,7	1,5	2	0,6	2,5	0,028	49
5,5	AGMEL 132 M 6c	960	12,7	54,7	0,75	83,1	83,1	82	4,9	1,6	2,2	0,7	2,6	0,036	63
7,5	AGMEL 160 M 6a	960	15,9	75,1	0,80	84,7	87,4	86,9	5	1,7	1,9	0,6	2,5	0,076	82
11	AGMEL 160 L 6b	960	23	109,4	0,8	86,4	86,4	86	5,4	1,8	1,9	0,6	2,6	0,109	108
15	AGMEL 180 L 6a	975	30	146,9	0,81	87,7	90,6	90	6,9	2,3	2,3	0,7	3,2	0,216	162
18,5	AGMEL 200 L 6a	965	36,9	183,9	0,82	88,6	90,2	90,3	5	1,7	1,6	0,5	2,3	0,227	215
22	AGMEL 200 L 6b	970	43,9	217,9	0,81	89,2	90,5	90,2	5,3	1,7	1,5	0,5	2,4	0,227	215
30	AGMEL 225 M 6a	980	58	292,3	0,83	90,2	90,2	89,2	7	2,3	3	1	2,6	0,56	280
37	AGMEL 250 M 6a	970	75	364,3	0,78	90,8	91,0	90,5	6,4	2,1	3	1	2,2	0,76	293

3 Phase, 400 V, 50 Hz, IE1



Duty Type
S1 (Continuous Operation)



Protection Class
IP 55



Insulation Class
F (155°C)



Temperature Rise
B (80 K)



Rated Power	Type	At Rated Power							At Starting				Breakdown Torque Ratio	Moment of Inertia	Approx Weight
		Speed	Current	Torque	Power Coefficient	Efficiency η			Current Ratio		Torque Ratio				
kW		RPM	A	Nm	Cos ϕ	4/4	3/4	1/2	Direct	Y/ Δ	Direct	Y/ Δ			

Aluminum Frame / 8 poles - 750 RPM

0,18	AGMEL 80 M 8a	710	0,9	2,4	0,76	38	37,6	37,4	2,5	-	1,6	-	2,3	0,00066	8,8
0,25	AGMEL 80 M 8b	720	1,2	3,4	0,69	43,4	43,4	43	2,7	-	1,6	-	2,4	0,0019	11,2
0,37	AGMEL 90 S 8a	720	1,65	4,9	0,65	49,7	49,2	49	2,8	-	1,6	-	2,2	0,001	10,4
0,55	AGMEL 90 L 8b	720	2,2	7,3	0,64	56,1	56	55,7	3,1	-	1,6	-	2,1	0,00066	8,8
0,75	AGMEL 100 L 8a	700	2,5	10,2	0,71	61,2	61,2	60	3,1	-	1,6	-	2	0,0062	18,1
1,1	AGMEL 100 L 8b	710	3,6	14,9	0,66	66,5	66,5	66	3,4	-	1,9	-	2,3	0,007	19,2
1,5	AGMEL 112 M 8a	700	4,40	20,5	0,70	70,2	71	71	3,6	-	1,9	-	2,2	0,018	31
2,2	AGMEL 132 S 8a	690	5,85	31,05	0,73	74,2	74,2	74	3,5	1,2	1,9	0,6	3,2	0,028	34
3	AGMEL 132 M 8b	690	7,8	41,5	0,72	77	79,1	77,3	3,7	1,2	2,3	1,2	2,4	0,036	63
4	AGMEL 160 M 8a	700	10,4	54,5	0,70	79,2	79,1	77,4	3,4	1,1	1,5	0,5	2	0,06	71
5,5	AGMEL 160 M 8b	710	15	76	0,65	81,4	80,3	77,5	4	1,3	2,3	0,7	2,6	0,06	71
7,5	AGMEL 160 L 8c	710	19,3	100,9	0,68	83,1	82,2	81,7	4,1	1,4	2,4	0,8	2,6	0,15	128
11	AGMEL 180 L 8a	715	26,2	148,6	0,71	85	86,7	85,4	4,4	1,5	2,1	0,7	2,6	0,18	140
15	AGMEL 200 L 8a	720	32,5	199,8	0,77	86,2	87,7	87,2	4,6	1,5	1,7	0,6	2,3	0,227	215
22	AGMEL 225 M 8b	735	39,4	285,35	0,78	86,9	86,9	86,5	6,3	2,1	1,7	0,6	1,9	0,48	250
18,5	AGMEL 225 S 8a	740	44	239,1	0,83	87,4	87,4	86,8	5,82	1,94	1,67	0,55	2,35	0,52	265
30	AGMEL 250 M 8a	735	59	389,8	0,82	88,3	88,3	87,2	6,1	2	1,8	0,6	2,6	0,92	380

3 Phase, 400 V, 50 Hz, IE2



Duty Type
S1 (Continuous Operation)



Protection Class
IP 55



Insulation Class
F (155°C)



Temperature Rise
B (80 K)



Rated Power	Type	At Rated Power							At Starting				Breakdown Torque Ratio	Moment of Inertia	Approx Weight
		Speed	Current	Torque	Power Coefficient	Efficiency η			Current Ratio		Torque Ratio				
kW		RPM	A	Nm	Cos ϕ	4/4	3/4	1/2	Direct	Y/ Δ	Direct	Y/ Δ			

Aluminum Frame / 2 poles - 3000 RPM

0,18	AGM2E 63 M 2a	2805	0,55	0,6	0,78	60,4	60,4	59,1	3,9	-	2,3	-	2,8	0,00011	3,6
0,25	AGM2E 63 M 2b	2830	0,65	0,8	0,86	64,8	64,8	64,3	4,3	-	2,9	-	3,3	0,00013	4
0,37	AGM2EL 71 M 2a	2800	1	1,3	0,77	69,5	69,5	67,9	5	-	2,4	-	2,6	0,00026	4,9
0,55	AGM2EL 71 M 2b	2740	1,3	1,9	0,83	74,1	77,4	76,8	4,1	-	2,2	-	2,4	0,00034	6
0,75	AGM2EL 80 M 2a	2845	1,7	2,5	0,82	77,4	77,4	76,4	4,5	1,5	2	0,7	2,7	0,00050	9
1,1	AGM2EL 80 M 2b	2835	2,5	3,7	0,8	79,6	79,6	78,6	4,3	1,4	1,8	0,6	2,7	0,00066	9,2
1,5	AGM2EL 90 S 2a	2865	3,2	5	0,83	81,3	81,3	80,2	5,2	1,7	1,9	0,6	2,5	0,0011	11,9
2,2	AGM2EL 90 L 2b	2875	4,5	7,3	0,85	83,2	83,2	82,3	6	-	2,2	-	2,8	0,0014	15,2
3	AGM2EL 100 L 2a	2880	5,80	9,9	0,88	84,6	84,6	84,1	6	-	2,5	-	3	0,0025	21,2
4	AGM2EL 112 M 2a	2880	7,90	13,3	0,85	85,8	85,8	85,6	7,2	2,3	2,8	0,9	3,5	0,0039	25,2
5,5	AGM2EL 132 S 2a	2905	9,85	18,1	0,93	87,0	87,0	86,5	6,5	2,1	2,2	0,7	2,5	0,013	41
7,5	AGM2EL 132 S 2b	2910	13,6	24,6	0,90	88,1	88,1	87,9	7,2	2,3	2,8	0,9	3	0,014	50
11	AGM2EL 160 M 2a	2945	19,3	35,7	0,92	89,4	89,4	88,6	6,6	2,1	2	0,6	2,6	0,027	82
15	AGM2EL 160 M 2b	2945	26,1	48,6	0,92	90,3	90,3	89,7	7,2	2,3	2,1	0,7	2,8	0,035	93,8
18,5	AGM2EL 160 L 2c	2950	32,3	59,9	0,91	90,9	90,8	90,1	7,7	2,5	2,5	0,8	3	0,043	110,3
22	AGM2EL 180 M 2a	2950	38,3	71,2	0,91	91,3	91,3	90,8	8,2	2,6	3	1	3,5	0,066	122
30	AGM2EL 200 L 2a	2970	52,0	96,5	0,91	92,0	92,0	91,2	8,3	2,7	2,7	0,9	3	0,13	142
37	AGM2EL 200 L 2b	2970	65,0	119	0,89	92,5	92,5	91,7	8,3	2,7	2,7	0,9	3	0,15	172
45	AGM2EL 225 M 2a	2975	75,0	144,5	0,93	92,9	93,0	91,8	8	2,6	2,4	0,8	2,9	0,23	375
55	AGM2EL 250 M 2a	2980	94,0	176,3	0,91	93,20	93,70	92,20	7,6	2,5	2,6	0,9	2,7	0,41	445

3 Phase, 400 V, 50 Hz, IE2



Duty Type
S1 (Continuous Operation)



Protection Class
IP 55



Insulation Class
F (155°C)



Temperature Rise
B (80 K)



Rated Power	Type	At Rated Power							At Starting				Breakdown Torque Ratio	Moment of Inertia	Approx Weight
		Speed	Current	Torque	Power Coefficient	Efficiency η			Current Ratio		Torque Ratio				
kW		RPM	A	Nm	Cos ϕ	4/4	3/4	1/2	Direct	Y/ Δ	Direct	Y/ Δ			
Aluminum Frame / 4 poles - 1500 RPM															
0,12	AGM2E 63 M 4a	1365	0,40	0,8	0,73	59,1	59,1	58	3,1	-	2	-	2,2	0,00017	3,4
0,18	AGM2E 63 M 4b	1340	0,55	1,3	0,73	64,7	64,7	63	2,9	-	2	-	2	0,00021	3,9
0,25	AGM2EL 71 M 4a	1415	0,79	1,7	0,67	68,5	65,5	59	3,3	-	1,6	-	2,2	0,0004	4,9
0,37	AGM2EL 71 M 4b	1410	1	2,5	0,73	72,7	70,5	67	3,6	-	1,8	-	2,2	0,00059	6,3
0,55	AGM2EL 80 M 4a	1420	1,5	3,7	0,69	77,1	77	76	4	-	1,9	-	2,4	0,00095	8,3
0,75	AGM2EL 80 M 4b	1415	1,9	5,1	0,72	79,6	79,5	78,6	4,3		2		2,5	0,0014	10,9
1,1	AGM2EL 90 S 4a	1420	2,5	7,4	0,78	81,4	81,4	80,4	4,7	-	2	-	2,4	0,0025	13,8
1,5	AGM2EL 90 L 4b	1435	3,5	10	0,75	82,8	82,7	81,8	5,2	-	2,3	-	3	0,0033	17
2,2	AGM2EL 100 L 4a	1420	4,90	14,8	0,77	84,3	84,3	82,5	5,6	-	2,4	-	2,7	0,0044	23,1
3	AGM2EL 100 L 4b	1435	6,3	20	0,80	85,5	85,7	84,0	6,4	-	2,9	-	3,4	0,0057	25,8
4	AGM2EL 112 M 4a	1440	8,40	26,5	0,79	86,6	86,8	85,3	6,6	2,2	2,5	0,8	3,3	0,0106	29,5
5,5	AGM2EL 132 S 4a	1465	11,2	35,9	0,81	87,7	87,7	87,2	7	2,3	2,8	0,9	3,5	0,021	38,4
7,5	AGM2EL 132 M 4b	1465	15,4	48,9	0,79	88,7	88,8	88,1	7,1	2,3	2,7	0,9	3,4	0,026	46,5
11	AGM2EL 160 M 4a	1460	21,6	72	0,82	89,8	89,9	89,3	6,8	2,2	2,4	0,8	3	0,061	86,3
15	AGM2EL 160 L 4b	1470	29,4	97,4	0,81	90,6	90,7	89,7	7,4	2,4	2,8	0,9	3,2	0,082	94
18,5	AGM2EL 180 M 4a	1470	34,5	120,2	0,85	91,2	91,4	90,4	7,7	2,5	3,2	1	3,4	0,13	129
22	AGM2EL 180 L 4b	1470	42,5	142,9	0,82	91,6	91,6	90,6	8,3	2,7	2,7	0,9	3,8	0,15	140
30	AGM2EL 200 L 4a	1470	53,5	194,9	0,88	92,3	92,3	92,1	7,8	2,5	2,8	0,9	2,8	0,227	215
37	AGM2EL 225 S 4a	1470	67,0	240,4	0,86	92,7	92,7	92,2	7,2	2,3	3	1	3	0,3	355
45	AGM2EL 225 M 4b	1470	80,0	292,3	0,87	93,1	93,1	92,4	7,3	2,4	3	1	3	0,36	375
55	AGM2EL 250 M 4a	1475	96,8	356,1	0,88	93,50	93,60	93,20	7,6	2,5	3,1	1,0	2,9	0,72	420

3 Phase, 400 V, 50 Hz, IE2



Duty Type
S1 (Continuous Operation)



Protection Class
IP 55



Insulation Class
F (155°C)



Temperature Rise
B (80 K)



Rated Power	Type	At Rated Power							At Starting				Breakdown Torque Ratio	Moment of Inertia	Approx Weight
		Speed	Current	Torque	Power Coefficient	Efficiency η			Current Ratio		Torque Ratio				
kW		RPM	A	Nm	cos ϕ	4/4	3/4	1/2	Direct	Y/ Δ	Direct	Y/ Δ			

Aluminum Frame / 6 poles - 1000 RPM

0,18	AGM2EL 71 M 6a	860	0,68	2	0,67	56,6	58,1	53,2	2,2	-	1,4	-	1,5	0,00064	5
0,25	AGM2EL 71 M 6b	895	0,9	2,7	0,65	61,6	60,7	56	2,5	-	1,7	-	2	0,00086	5,7
0,37	AGM2EL 80 M 6a	920	1,2	3,84	0,66	67,6	67,6	65	2,8	-	1,4	-	1,9	0,00095	8,3
0,55	AGM2EL 80 M 6b	950	1,75	5,6	0,65	73,1	72,5	69,6	3,4	-	1,6	-	2,4	0,00095	8,3
1,1	AGM2EL 90 L 6b	950	3,1	11,1	0,66	78,1	78,1	77,1	4,1	-	2	-	2,6	0,0051	15,2
1,5	AGM2EL 100 L 6a	945	3,6	15,2	0,75	79,8	79,7	76,4	4,5	-	2,2	-	2,4	0,0077	19,3
2,2	AGM2EL 112 M 6a	950	5,4	22,1	0,72	81,8	81,7	78,5	4,7	-	2,2	-	2,5	0,013	26,1
3	AGM2EL 132 S 6a	960	7,10	29,8	0,73	83,3	83,2	80,4	4,6	1,5	1,8	0,6	2,3	0,019	35
4	AGM2EL 132 M 6b	960	9,30	39,8	0,73	84,6	84,5	81,6	4,7	1,5	2	0,6	2,5	0,024	44
5,5	AGM2EL 132 M 6c	960	12,7	54,7	0,73	86,0	86,0	83,1	4,9	1,6	2,2	0,7	2,6	0,032	54,8
7,5	AGM2EL 160 M 6a	975	16,0	73,5	0,78	87,2	87,2	84,5	6,3	2	2,6	0,8	3,5	0,076	82
11	AGM2EL 160 L 6b	970	22,5	108,3	0,80	88,7	88,7	85,7	6,2	2	3	1	3	0,109	108
15	AGM2EL 180 L 6a	965	29,0	148,4	0,83	89,7	89,7	86,8	6,5	2,1	2,4	0,8	3	0,2	147
18,5	AGM2EL 200 L 6a	980	37,1	180,3	0,80	90,4	90,4	87,7	7,2	2,32	2,3	0,7	3,2	0,234	167
22	AGM2EL 200 L 6b	980	43,4	214,4	0,80	90,9	90,9	88,4	6,7	2,3	2,3	0,7	2,8	0,283	187
30	AGM2EL 225 M 6a	980	58,0	292,3	0,81	91,7	91,7	89,6	7	2,3	3	1	2,6	0,57	
37	AGM2EL 250 M 6a	985	71,4	358,7	0,81	92,20	92,20	90,10	7,0	2,3	3,0	1,0	2,6	0,77	380

Aluminum Frame / 8 poles - 750 RPM

0,12	AGM2EL 71 M 8b	675	0,6	1,7	0,72	39,8	39,8	37	2,2	-	1,9	-	2	0,00089	6
0,18	AGM2EL 80 M 8a	710	0,9	2,45	0,63	45,9	45,9	44	2,6	-	2,2	-	2,7	0,0019	8,6
0,25	AGM2EL 80 M 8b	700	1,3	3,4	0,65	50,6	50,6	48	2,8	-	2,6	-	2,8	0,0025	10
0,37	AGM2EL 90 S 8a	715	1,5	4,92	0,63	56,1	56,1	54	2,8	-	1,6	-	2,2	0,003	12
0,55	AGM2EL 90 L 8b	710	2,1	7,47	0,61	61,7	61,7	60	3,1	-	1,6	-	2,1	0,004	13,8

3 Phase, 400 V, 50 Hz, IE3



Duty Type
S1 (Continuous Operation)



Protection Class
IP 55



Insulation Class
F (155°C)



Temperature Rise
B (80 K)



Rated Power	Type	At Rated Power							At Starting				Breakdown Torque Ratio	Moment of Inertia	Approx Weight
		Speed	Current	Torque	Power Coefficient	Efficiency η			Current Ratio		Torque Ratio				
kW		RPM	A	Nm	Cos ϕ	4/4	3/4	1/2	Direct	Y/ Δ	Direct	Y/ Δ			

Aluminum Frame / 2 poles - 3000 RPM

0,18	AGM3E 63 M 2a	2805	0,55	0,6	0,74	65,9	65,9	61,3	3,9	-	2,3	-	2,8	0,00011	3,6
0,25	AGM3E 63 M 2b	2830	0,7	0,8	0,75	69,7	69,7	68,3	4,3	-	2,9	-	3,3	0,00013	4
0,37	AGM3EL 71 M 2a	2775	0,89	1,3	0,82	73,8	75,5	73,9	3,8	-	1,9	-	2,4	0,00028	5,2
0,55	AGM3EL 71 M 2b	2785	1,28	1,9	0,8	77,8	77,3	74,9	4,4	-	2,4	-	2,6	0,00036	6,3
0,75	AGM3EL 80 M 2a	2860	1,6	2,5	0,84	80,7	80,7	80,4	5,7	-	2,4	-	3,0	0,00050	9
1,1	AGM3EL 80 M 2b	2865	2,3	3,7	0,83	82,7	82,7	82,1	5,9	-	2,8	-	3,4	0,00066	9,2
1,5	AGM3EL 90 S 2a	2895	3,1	4,9	0,83	84,2	84,2	83	6,5	-	2,4	-	3,2	0,0014	13,5
2,2	AGM3EL 90 L 2b	2900	4,8	7,24	0,77	85,9	85,9	85,5	6,9	2,3	3,1	1	3,5	0,0095	16
3	AGM3EL 100 L 2a	2910	6,1	9,84	0,81	87,1	87,1	86,5	7,4	2,5	2,7	0,9	3,9	0,09	22
4	AGM3EL 112 M 2a	2900	7,5	13,1	0,88	88,1	87,5	86,3	7,4	2,5	2,5	0,8	3,5	0,0048	24,1
5,5	AGM3EL 132 S 2a	2925	10,2	18	0,87	89,2	89,0	87,4	7,2	2,3	2,1	0,7	3,0	0,015	51
7,5	AGM3EL 132 M 2b	2925	13,5	24,5	0,93	90,1	90,1	89,5	7,6	2,5	2,6	0,9	3,3	0,021	63
11	AGM3EL 160 M 2a	2950	19,8	35,7	0,92	91,2	91,2	90,4	7,2	2,3	2,2	0,6	3,0	0,031	90
15	AGM3EL 160 M 2b	2955	25,7	48,5	0,92	91,9	91,8	91,2	7,9	2,5	2,2	0,7	2,9	0,041	105
18,5	AGM3EL 160 L 2c	2960	31,4	59,7	0,92	92,4	92,5	92,0	8,1	2,6	2,2	0,7	3,1	0,049	122
22	AGM3EL 180 M 2a	2960	36,9	71	0,93	92,7	92,6	92,2	8,5	2,7	2,9	0,9	3,4	0,091	157
30	AGM3EL 200 L 2a	2955	51,8	96,9	0,9	93,3	93,4	92,9	7,5	2,5	2,5	0,8	3	0,116	161
37	AGM3EL 200 L 2b	2980	63,0	118,6	0,90	93,7	93,7	93,1	8,3	2,7	2,8	0,9	3,1	0,17	191
45	AGM3EL 225 M 2a	2975	78,3	144,6	0,89	94	93,9	93,1	8,0	2,7	2,7	0,9	3,0	0,26	400
55	AGM3EL 250 M 2a	2985	92,0	176	0,92	94,3	94,5	93,3	8,7	2,9	2,9	1,0	3,0	0,41	445

3 Phase, 400 V, 50 Hz, IE3



Duty Type
S1 (Continuous Operation)



Protection Class
IP 55



Insulation Class
F (155 °C)



Temperature Rise
B (80 K)



Rated Power	Type	At Rated Power							At Starting				Breakdown Torque Ratio	Moment of Inertia	Approx Weight
		Speed	Current	Torque	Power Coefficient	Efficiency η			Current Ratio		Torque Ratio				
kW		RPM	A	Nm	Cos ϕ	4/4	3/4	1/2	Direct	Y/ Δ	Direct	Y/ Δ			

Aluminum Frame / 4 poles - 1500 RPM

0,12	AGM3E 63 M 4a	1370	0,45	0,8	0,59	64,8	61,5	55,3	2,9	-	2,2	-	2,4	0,00071	3,4
0,18	AGM3E 63 M 4b	1380	0,62	1,25	0,6	69,9	68	62,8	2,8	-	2,1	-	2,5	0,00019	3,7
0,25	AGM3EL 71 M 4a	1425	0,73	1,7	0,68	73,5	72,6	68	4	-	1,9	-	2,5	0,00059	6,3
0,37	AGM3EL 71 M 4b	1420	1	2,5	0,7	77,3	75,6	72	4,1	-	2	-	2,4	0,00077	7,8
0,55	AGM3EL 80 M 4a	1430	1,5	3,6	0,66	80,8	80,7	79,8	5	-	2,5	-	3	0,00095	8,3
0,75	AGM3EL 80 M 4b	1430	1,83	5	0,73	82,5	81,2	78,9	5,1	-	2,5	-	2,7	0,0015	11
1,1	AGM3EL 90 S 4a	1450	2,5	7,2	0,76	84,1	84	83	6,1	-	2,7	-	3,5	0,0025	13,8
1,5	AGM3EL 90 L 4b	1450	3,5	9,9	0,75	85,3	85,3	84,3	6,3	-	2,9	-	3,6	0,0033	17
2,2	AGM3EL 100 L 4a	1445	4,7	14,5	0,78	86,7	86,8	85,0	5,9	-	2,7	-	3,3	0,0052	26,3
3	AGM3EL 100 L 4b	1445	6,60	19,8	0,75	87,7	87,8	86,1	6,7	-	2,5	-	3,4	0,0057	25,8
4	AGM3EL 112 M 4a	1450	8,00	26,3	0,81	88,6	88,5	88,0	7	2,4	2,8	0,95	3,45	0,012	36
5,5	AGM3EL 132 S 4a	1450	11,0	36,2	0,81	89,6	89,6	88,8	6	2	2,4	0,9	3	0,026	38,4
7,5	AGM3EL 132 M 4b	1450	15,1	49,3	0,8	90,4	90,5	89,6	5,9	2	2,5	0,9	2,80	0,032	49,3
11	AGM3EL 160 M 4a	1470	21,6	71,5	0,81	91,4	91	90,6	7,5	2,5	2,6	0,87	3,1	0,066	98
15	AGM3EL 160 L 4b	1475	29,7	97,1	0,79	92,1	92,0	91,8	7,5	2,5	2,5	0,85	3,3	0,102	115
18,5	AGM3EL 180 M 4a	1475	34,0	119,8	0,85	92,6	92,6	91,6	8,5	2,7	2,9	0,95	3,9	0,177	160
22	AGM3EL 180 L 4b	1475	38	142,4	0,87	93,0	92,8	92,0	7,5	2,4	2,9	1	3,5	0,192	176
30	AGM3EL 200 L 4a	1476	54,7	194,1	0,85	93,6	93,2	92,6	8,7	2,9	3,5	1,15	3,7	0,23	207
37	AGM3EL 225 S 4a	1475	67,0	239,6	0,85	93,9	93,9	93,5	7,5	2,4	3,1	1	3,3	0,36	350
45	AGM3EL 225 M 4b	1480	80,2	290,5	0,86	94,2	94,3	94	7,97	2,7	3,4	1,1	3,1	0,44	380
55	AGM3EL 250 M 4a	1480	96,0	354,9	0,87	94,6	94,7	94	7,7	2,6	3,2	1,1	3	0,72	420

3 Phase, 400 V, 50 Hz, IE3



Duty Type
S1 (Continuous Operation)



Protection Class
IP 55



Insulation Class
F (155°C)



Temperature Rise
B (80 K)



Rated Power	Type	At Rated Power							At Starting				Breakdown Torque Ratio	Moment of Inertia	Approx Weight
		Speed	Current	Torque	Power Coefficient	Efficiency η			Current Ratio		Torque Ratio				
kW		RPM	A	Nm	Cos ϕ	4/4	3/4	1/2	Direct	Y/ Δ	Direct	Y/ Δ			
Aluminum Frame / 6 poles - 1000 RPM															
0,37	AGM3EL 80 M 6a	945	1,1	3,7	0,66	73,5	74	70,1	3,7	-	1,9	-	2,4	0,00066	9,2
0,55	AGM3EL 80 H 6b	940	1,6	5,6	0,64	77,2	75	72,1	3,4	-	1,7	-	2	0,0020	11,4
0,75	AGM3EL 90 S 6a	950	2	7,6	0,69	78,9	78,9	77,9	4,1	-	1,7	-	2,3	0,0038	13,2
1,1	AGM3EL 90 L 6b	950	3	11,1	0,65	81	81	80	4,4	-	2	-	2,6	0,0051	15,1
1,5	AGM3EL 100 L 6a	955	3,60	15	0,73	82,5	82,3	80,3	5,1	-	2,4	-	3	0,011	22,8
2,2	AGM3EL 112 M 6a	960	5,30	21,9	0,71	84,3	84,1	82,1	5,8	-	2,6	-	3,2	0,016	30
3	AGM3EL 132 S 6a	960	7,10	29,8	0,73	83,3	83,2	85,2	5,4	1,7	2,1	0,7	2,9	0,023	39
4	AGM3EL 132 M 6b	975	10,2	39,2	0,65	86,8	86,7	86,4	5,6	1,8	2,5	0,8	3,1	0,028	49
5,5	AGM3EL 132 M 6c	975	13,7	53,9	0,66	88,0	87,8	87,5	5,9	1,9	2,6	0,8	3,3	0,036	63
7,5	AGM3EL 160 M 6a	970	16,2	73,8	0,75	89,1	89,0	88,1	6,7	2,2	2,6	0,8	3,4	0,091	96
11	AGM3EL 160 L 6b	975	24	107,7	0,77	90,3	90,3	89,0	7,6	2,5	3	1	3,8	0,13	122
15	AGM3EL 180 L 6a	975	28,5	147	0,83	91,2	91,8	91,5	6	2	1,6	0,6	2,5	0,216	162
18,5	AGM3EL 200 L 6a	980	37,5	180,3	0,78	91,7	91,6	91,3	7,9	2,5	2,6	0,9	3,7	0,289	188
22	AGM3EL 200 L 6b	980	42,2	214,4	0,82	92,2	92,0	91,7	6,8	2,2	1,9	0,7	3,1	0,344	215
30	AGM3EL 225 M 6a	985	58,0	290,9	0,80	92,9	92,9	92,1	7	2,3	3,3	1,1	2,7	0,69	350
37	AGM3EL 250 M 6a	985	70,0	358,7	0,82	93,3	93,2	92,9	7	2,3	2,8	0,9	2,6	0,77	380

3 Phase, 400 V, 50 Hz, IE3



Duty Type
S1 (Continuous Operation)



Protection Class
IP 55



Insulation Class
F (155°C)



Temperature Rise
B (80 K)



Rated Power	Type	At Rated Power							At Starting				Breakdown Torque Ratio	Moment of Inertia	Approx Weight
		Speed	Current	Torque	Power Coefficient	Efficiency η			Current Ratio		Torque Ratio				
kW		RPM	A	Nm	Cos ϕ	4/4	3/4	1/2	Direct	Y/ Δ	Direct	Y/ Δ			

Aluminum Frame / 8 poles - 750 RPM

0,18	AGM3EL 80 M 8a	710	0,9	2,4	0,49	58,7	52,4	44,2	2,5	-	1,6	-	2,3	0,00095	8,3
0,25	AGM3EL 80 M 8b	720	1,2	3,4	0,47	64,1	57,6	49,6	2,7	-	1,6	-	2,4	0,00095	8,3
0,37	AGM3EL 90 S 8a	715	1,5	4,92	0,51	69,3	69,3	98	2,8	-	1,6	-	2,2	0,0038	13,2
0,55	AGM3EL 90 L 8b	710	2,1	7,47	0,52	73	68,1	62,2	3,1	-	1,6	-	2,1	0,0051	15,1
0,75	AGM3EL 100 L 8a	710	2,3	10,1	0,63	75	75	74	3,6	-	1,8	-	2,2	0,0062	18,1
1,1	AGM3EL 100 L 8b	715	3,3	14,7	0,61	77,7	76,8	76	4,2	-	2,1	-	2,67	0,007	19,2
1,5	AGM3EL 112 M 8a	710	4,45	20,2	0,61	79,7	79,7	78,5	4,1	-	2,2	-	2,6	0,018	31
2,2	AGM3EL 132 S 8a	705	5,2	29,8	0,75	81,9	81,2	81,1	4,5	1,5	2,35	0,8	2,7	0,028	34
3	AGM3EL 132 M 8b	700	6,9	40,9	0,76	83,5	83,5	82,5	4,4	1,4	2,4	0,8	2,6	0,023	39
4	AGM3EL 160 M 8a	710	9,2	53,8	0,74	84,8	84,8	83,8	4,3	1,4	1,8	0,6	2,3	0,06	71
5,5	AGM3EL 160 M 8b	720	12,9	73	0,72	86,2	86,2	85,2	5,4	1,8	2,4	0,7	3	0,092	81
7,5	AGM3EL 160 L 8c	720	17,65	99,5	0,7	87,3	87,3	86,3	1,85	0,6	2	0,7	2,1	0,15	128
11	AGM3EL 180 L 8a	725	23,2	144,9	0,78	88,6	88,5	87,7	6,3	2,1	2,8	0,9	3,4	0,18	140
15	AGM3EL 200 L 8a	725	31	197,6	0,78	89,6	89,6	88,6	6,1	2	2,3	0,8	3,1	0,34	162
18,5	AGM3EL 225 S 8a	740	38,8	239,1	0,76	90,1	90,1	89,3	6,3	2,1	1,7	0,6	1,9	0,48	228
22	AGM3EL 225 M 8b	735	44,1	285,35	0,8	90,6	90,6	89,6	5,82	1,94	1,67	0,55	2,35	0,52	232
30	AGM3EL 250 M 8a	735	59	389,8	0,8	91,3	91,3	90,3	6,1	2	1,8	0,6	2,6	0,77	380

3 Phase, 400 V, 50 Hz, IE4



Duty Type
S1 (Continuous Operation)



Protection Class
IP 55



Insulation Class
F (155°C)



Temperature Rise
B (80 K)



Rated Power	Type	At Rated Power							At Starting				Breakdown Torque Ratio	Moment of Inertia	Approx Weight
		Speed	Current	Torque	Power Coefficient	Efficiency η			Current Ratio		Torque Ratio				
kW		RPM	A	Nm	Cos ϕ	4/4	3/4	1/2	Direct	Y/ Δ	Direct	Y/ Δ			

Aluminum Frame / 2 poles - 3000 RPM

0,18	AGM4E 63 M 2a	2820	0,55	0,6	0,67	70,8	68	66	4,6	-	2,9	-	2,9	0,00011	3,6
0,25	AGM4E 63 M 2b	2840	0,65	0,8	0,75	74,3	72	70	4,5	-	2,5	-	2,9	0,00013	4
0,75	AGM4EL 80 M 2a	2900	1,7	2,5	0,76	83,5	81,5	78,1	6,7	-	3,2	-	4,1	0,00066	8,8
1,1	AGM4EL 80 H 2b	2870	2,3	3,7	0,81	85,2	85,4	84,3	6,6	-	3,2	-	3,7	0,001	10,4
1,5	AGM4EL 90 L 2a	2910	3	4,9	0,83	86,5	85,3	83,4	6,9	-	2,8	-	3,7	0,0014	15,2
2,2	AGM4EL 90 L 2b	2910	4,4	7,2	0,82	88	86,7	84,8	6,9	-	3,4	-	4,1	0,0014	15,2
3	AGM4EL 100 L 2a	2915	5,6	9,8	0,87	89,1	88	86,6	8,3	-	3,1	-	3,9	0,0031	22
4	AGM4EL 112 H 2a	2895	6,7	13,2	0,96	90	88,5	88,4	7,3	2,4	2,3	0,8	3	0,0045	28,2
5,5	AGM4EL 132 S 2a	2930	9,9	17,9	0,88	90,9	89,9	88,7	6,7	2,2	2,6	0,9	3,5	0,013	41
7,5	AGM4EL 132 M 2b	2930	12,3	24,4	0,96	91,7	91,5	91,5	7,4	2,5	2,2	0,7	3	0,021	63
11	AGM4EL 160 M 2a	2950	17,5	35,6	0,98	92,6	92	91,3	7,6	2,5	2	0,7	2,9	0,035	93,8
15	AGM4EL 160 L 2b	2960	25,5	48,4	0,91	93,3	93,1	92,3	9,1	3	2,5	0,8	3,4	0,043	110,3
18,5	AGM4EL 160 L 2c	2955	31,3	59,6	0,91	93,7	93,9	93,9	8,5	2,8	2,3	0,8	3,2	0,043	110,3
22	AGM4EL 180 M 2a	2950	36,1	70,9	0,94	94	93,8	93,9	8,8	2,9	2,7	0,9	3,5	0,066	122
30	AGM4EL 200 L 2a	2965	50,2	96,5	0,91	94,5	94,5	93,8	8,8	2,9	3,1	1	3,4	0,15	161
37	AGM4EL 200 H 2b	2970	61,9	119,1	0,91	94,8	94,8	94,2	8,7	2,9	3,1	1	3,2	0,579	264
45	AGM4EL 225 M 2a	2975	74,4	144,4	0,92	95,0	94,9	94,4	8,5	2,8	2,8	0,9	3,0	0,67	400
55	AGM4EL 250 M 2a	2980	92	176,2	0,91	95,3	95	94,6	9,1	3,0	3,0	1,0	3,3	0,37	480

Aluminum Frame / 4 poles - 1500 RPM

0,55	AGM4EL 80 H 4a	1450	1,4	3,6	0,68	83,9	82,5	79,4	6,1	-	3,2	-	3,7	0,0019	11,2
1,1	AGM4EL 90 L 4a	1450	2,4	7,2	0,76	87,2	86,3	84,8	6,6	-	2,9	-	3,3	0,0014	15,2
1,5	AGM4EL 90 H 4b	1450	3,3	9,9	0,74	88,2	86,9	85,2	7,4	-	3,6	-	3,8	0,0020	18,3
7,5	AGM4EL 160 M 4e	1480	15	48,4	0,78	92,6	92,2	90,9	9,1	3	3,1	1	4,1	0,076	90
11	AGM4EL 160 H 4a	1480	22,4	70,9	0,77	93,3	92,7	91,4	8,0	2,7	3,0	1,0	4,2	0,102	115
15	AGM4EL 180 M 4d	1475	26	97,1	0,89	93,9	93,6	93,3	8,7	2,9	2,7	0,9	3,4	0,190	176
18,5	AGM4EL 180 M 4a	1480	33,2	119,4	0,85	94,2	93,7	93	9,3	3,1	3,2	1,1	4,0	0,192	182
22	AGM4EL 180 L 4b	1475	39,2	142,3	0,86	94,5	94,1	93,6	8,4	2,8	2,7	0,9	3,6	0,228	215
30	AGM4EL 200 H 4a	1480	52,9	193,9	0,86	94,9	94,8	94,4	9,4	3,1	3,4	1,1	3,9	0,581	267
37	AGM4EL 225 S 4a	1480	65,3	238,7	0,86	95,2	95,2	94,5	8,8	2,9	3,5	1,2	3,4	0,6	350
45	AGM4EL 225 M 4b	1480	79,2	290,4	0,86	95,4	95,2	94,6	9,3	3,1	3,9	1,3	3,6	0,67	380
55	AGM4EL 250 M 4a	1485	105,1	353,7	0,79	95,7	95,7	95	8,5	2,8	4,3	1,4	3,5	0,77	460

3 Phase, 400 V, 50 Hz, IE4



Duty Type
S1 (Continuous Operation)



Protection Class
IP 55



Insulation Class
F (155°C)



Temperature Rise
B (80 K)



Rated Power	Type	At Rated Power							At Starting				Breakdown Torque Ratio	Moment of Inertia	Approx Weight
		Speed	Current	Torque	Power Coefficient	Efficiency η			Current Ratio		Torque Ratio				
kW		RPM	A	Nm	cos ϕ	4/4	3/4	1/2	Direct	Y/ Δ	Direct	Y/ Δ			

Aluminum Frame / 6 poles - 1000 RPM

0,37	AGM4EL 80 H 6a	960	1,1	3,7	0,62	78	75,4	70,9	4,4	-	2,2	-	2,9	0,0019	11,2
0,75	AGM4EL 90 S 6a	960	2,1	7,5	0,62	82,7	80,2	76,6	4,8	-	2,2	-	2,9	0,0038	13,3
1,1	AGM4EL 90 H 6b	960	2,9	10,85	0,65	84,5	83,8	81,2	4,9	-	2,1	-	3,1	0,0020	18,3
1,5	AGM4EL 100 H 6a	960	3,6	14,9	0,7	85,9	85,2	83,6	5,1	-	2,2	-	2,7	0,0076	28,3
3	AGM4EL 132 S 6a	970	6,7	29,5	0,73	88,6	89,1	88,2	6	2	2,3	1,2	2,9	0,019	35
4	AGM4EL 132 M 6b	970	9,5	39,2	0,68	89,5	88,7	87,1	6,4	2,1	2,8	0,9	3,4	0,024	44
5,5	AGM4EL 132 M 6c	970	12,5	54,1	0,7	90,5	90,5	89	5,4	1,8	2,1	0,7	2,7	0,028	49
7,5	AGM4EL 160 M 6a	980	15,6	73,4	0,76	91,3	90,8	89,9	7,5	2,5	2,6	0,9	3,7	0,076	82
15	AGM4EL 180 L 6a	980	29,8	146,9	0,78	92,9	92,6	91,75	7	2,3	1,9	0,6	3,3	0,15	140
18,5	AGM4EL 200 L 6a	980	37,3	181,1	0,77	93,4	93,3	92,4	8,3	2,8	2,4	0,8	4,1	0,264	225
22	AGM4EL 200 H 6b	980	43,5	213,8	0,78	93,7	93,9	93,1	7,6	2,5	1,9	0,6	3,6	0,579	264
30	AGM4EL 225 M 6a	990	57,5	289,4	0,8	94,2	94,2	93,5	7,1	2,4	3,1	1,0	2,7	0,85	400
37	AGM4EL 250 M 6a	990	70,7	356,9	0,8	94,5	94	93,3	7,5	2,5	3,3	1,1	2,9	1,04	440

Aluminum Frame / 8 poles - 750 RPM

0,37	AGM4EL 90 S 8a	725	1,3	5	0,55	74,3	74,3	73,8	3,1	-	1,2	-	1,8	0,0038	13,3
0,55	AGM4EL 90 H 8b	710	1,8	7,5	0,59	77	75,1	71,8	3	-	1	-	1,7	0,05	17,7
0,75	AGM4EL 100 L 8a	715	2,3	10,06	0,6	78,4	77,2	73,6	4	-	2,1	-	2,6	0,0057	25,8
1,1	AGM4EL 100 H 8b	710	3,4	15	0,58	80,8	79,1	76,3	3,9	-	2,1	-	2,4	0,0076	28,3
1,5	AGM4EL 112 H 8a	715	4,5	20,2	0,58	82,6	80	77	4,1	-	2,1	-	2,6	0,015	36
2,2	AGM4EL 132 S 8a	710	5,9	29,8	0,64	84,5	82,6	80,2	4,5	1,5	2,6	0,9	3	0,019	35
3	AGM4EL 132 M 8b	710	7,65	40,2	0,66	85,9	84,3	82,2	5	1,7	2,9	0,9	3,2	0,03	36
4	AGM4EL 160 M 8a	720	10,3	53,2	0,64	87,1	85,7	83,6	4,8	1,6	2,2	0,7	2,9	0,076	82
5,5	AGM4EL 160 M 8b	730	14	72,4	0,64	88,3	87,3	85,5	5,5	1,8	2,5	0,8	3,3	0,091	96
7,5	AGM4EL 160 L 8c	730	17,9	99,5	0,68	89,3	88,6	87,1	5,8	1,9	2,3	0,8	3,3	0,124	132
11	AGM4EL 180 L 8a	730	23,1	144,7	0,76	90,4	90,7	90	6,7	2,2	3	1	3,6	0,2	147
15	AGM4EL 200 L 8a	730	34,9	195,9	0,68	91,2	89,9	88,3	6	2	2,5	0,8	3,5	0,289	188

3 Phase, 400 V, 50 Hz, IE1



Duty Type
S1 (Continuous Operation)



Protection Class
IP 55



Insulation Class
F (155°C)



Temperature Rise
B (80 K)



Rated Power	Type	At Rated Power							At Starting				Breakdown Torque Ratio	Moment of Inertia	Approx Weight
		Speed	Current	Torque	Power Coefficient	Efficiency η			Current Ratio		Torque Ratio				
kW		RPM	A	Nm	Cos ϕ	4/4	3/4	1/2	Direct	Y/ Δ	Direct	Y/ Δ			

Cast Iron Frame / 2 poles - 3000 RPM

5,5	GMEL 132 S 2a	2900	10	18,1	0,94	84,7	86,2	85,8	5,6	1,8	2	0,7	2,8	0,015	66,5
7,5	GMEL 132 S 2b	2910	13,1	24,6	0,96	86	87,5	87,9	5,8	2	2,2	0,7	2,9	0,015	66,5
11	GMEL 160 M 2a	2940	21,8	35,8	0,75	87,6	87,8	87,1	5,5	1,8	1,6	0,5	2,4	0,027	91
15	GMEL 160 M 2b	2940	27,5	48,8	0,89	88,7	88,7	88	6,3	2,1	1,6	0,5	2,7	0,035	117
18,5	GMEL 160 L 2c	2950	33,5	59,9	0,89	89,3	89,3	89	7,1	2,4	1,9	0,6	3	0,043	135
22	GMEL 180 M 2a	2955	40,8	71,1	0,87	89,9	89,9	89	7,8	2,7	2,3	0,7	3,5	0,066	158
30	GMEL 200 L 2a	2960	53	96,7	0,90	90,7	90,7	89,8	7,8	2,6	2,7	0,9	3,1	0,13	190
37	GMEL 200 L 2b	2960	64,5	119,2	0,91	91,2	91,2	90,3	7,7	2,6	2,8	0,9	3,1	0,15	220
45	GMEL 225 M 2a	2970	77,9	144,5	0,91	91,7	91,7	90,8	8	2,6	2,4	0,8	2,9	0,23	375
55	GM 250 M 2a	2970	100	176,7	0,86	92,1	92,3	92,0	7,6	2,5	2,6	0,9	2,7	0,32	350
75	GM 280 S 2a	2975	136	240,7	0,86	92,7	92,9	92,5	7	2,3	2,4	0,8	2,5	0,53	512
90	GM 280 M 2b	2970	160	288,9	0,87	93	93	92,7	8,3	2,8	2,6	0,9	2,9	0,55	522
110	GM 315 S 2a	2980	197	352,5	0,86	93,3	93,2	93,0	7,2	2,4	2,6	0,9	3,1	0,94	635
132	GM 315 M 2b	2980	235	423	0,87	93,5	93,5	93,0	8,3	2,8	2,6	0,9	3,1	1,1	680
160	GM 315 M 2c	2980	266	512,7	0,93	93,8	93,7	92,9	8	2,7	2,7	0,9	3,3	1,3	756

Cast Iron Frame / 4 poles - 1500 RPM

5,5	GMEL 132 S 4a	1440	12	36,5	0,78	84,7	85,7	84,4	4,6	1,5	1,9	0,6	2,4	0,021	48
7,5	GMEL 132 M 4b	1450	15,8	49,5	0,80	86	87,7	87,1	5,1	1,7	2,1	0,7	2,6	0,032	56
11	GMEL 160 M 4a	1455	22,3	72,3	0,81	87,6	88,4	88	5,2	1,7	1,9	0,6	2,4	0,076	124
15	GMEL 160 L 4b	1455	31,2	98,5	0,78	88,7	88,7	88,2	5,4	1,8	2	0,7	2,5	0,082	132
18,5	GMEL 180 M 4a	1465	34,6	120,8	0,86	89,3	91	90,7	6,2	2,1	2	0,7	2,7	0,13	165
22	GMEL 180 L 4b	1470	41,4	143,8	0,85	89,9	91,5	90,9	6,5	2,2	2,1	0,7	2,8	0,15	180
30	GMEL 200 L 4a	1465	57	197	0,84	90,7	90,7	89,8	6,5	2,2	2,4	0,8	2,9	0,13	190
55	GM 250 M 4a	1470	102	357,3	0,85	92,1	92,3	92	6,4	2,3	2,5	0,8	2,6	0,6	350
75	GM 280 S 4a	1475	140	485,6	0,83	92,7	92,5	92	6,4	2,1	2,2	0,7	2,4	0,9	530
90	GM 280 M 4b	1480	166	580,7	0,84	93	93	92,2	6,9	2,1	2,6	0,9	2,7	1,11	595
110	GM 315 S 4a	1485	195	707,4	0,87	93,3	93,3	92,5	6,9	2,3	1,8	0,7	2,6	1,85	692
132	GM 315 M 4b	1480	247	851,8	0,82	93,5	93,5	92,8	6,8	2,1	1,7	0,7	2,6	2,26	780
160	GM 315 M 4c	1485	296	1028,9	0,83	93,8	92,0	92,0	6,8	2,1	1,7	0,7	2,6	2,76	953
185	GMM 315 L 4d	1485	323	1189,6	0,87	94	94	93	7,1	2,4	2	0,7	2,8	3,01	1051
200	GMM 315 L 4e	1485	370	1286,1	0,83	94	94,0	93,5	7,8	2,6	2,4	0,8	2,9	3,34	1168



3 Phase, 400 V, 50 Hz, IE1



Duty Type
S1 (Continuous Operation)



Protection Class
IP 55



Insulation Class
F (155°C) - H(180°C)



Temperature Rise
B (80 K)



Rated Power	Type	At Rated Power						At Starting				Breakdown Torque Ratio	Moment of Inertia	Approx Weight	
		Speed	Current	Torque	Power Coefficient	Efficiency η			Current Ratio		Torque Ratio				
kW		RPM	A	Nm	Cos ϕ	4/4	3/4	1/2	Direct	Y/ Δ	Direct	Y/ Δ			
Cast Iron Frame / 6 poles - 1000 RPM															
3	GMEL 132 S 6a	960	7,1	29,8	0,77	79,7	79,6	78	4,6	1,5	1,8	0,6	2,3	0,023	53
4	GMEL 132 M 6b	960	9,3	39,8	0,76	81,4	81,3	80	4,7	1,5	2	0,6	2,5	0,028	62
5,5	GMEL 132 M 6c	960	12,7	54,7	0,75	83,1	83,1	82	4,9	1,6	2,2	0,7	2,6	0,028	62
7,5	GMEL 160 M 6a	960	15,9	75,1	0,80	84,7	87,4	86,9	5	1,7	1,9	0,6	2,5	0,076	105
11	GMEL 160 L 6b	960	23	109,4	0,8	86,4	86,4	86	5,4	1,8	1,9	0,6	2,6	0,109	133
15	GMEL 180 L 6a	975	30	146,9	0,81	87,7	90,6	90	6,9	2,3	2,3	0,7	3,2	0,2	186
18,5	GMEL 200 L 6a	965	36,9	183,9	0,82	88,6	90,2	90,3	5	1,7	1,6	0,5	2,3	0,234	203
22	GMEL 200 L 6b	970	43,9	217,9	0,81	89,2	90,5	90,2	5,3	1,7	1,5	0,5	2,4	0,283	231
30	GMEL 225 M 6a	980	58	292,3	0,83	90,2	90,2	89,2	7	2,3	3	1	2,6	0,56	278
37	GM 250 M 6a	970	75	364,3	0,78	90,8	91,0	90,5	6,4	2,1	3	1	2,2	0,76	378
45	GM 280 S 6a	980	92	438,5	0,77	91,4	91,4	91,0	7	2,3	3,3	1,1	2,6	1,2	500
55	GM 280 M 6b	985	112	533,2	0,77	91,9	91,9	91,6	7	2,3	3,3	1,1	2,6	1,5	553
75	GM 315 S 6a	985	146	727,1	0,80	92,6	92,6	92,2	6,8	2,3	1,9	0,6	2,9	1,98	698
90	GM 315 M 6b	990	166	868,1	0,84	92,9	92,9	92	6,8	2,3	1,9	0,6	2,9	2,38	750
110	GM 315 M 6c	990	197,6	1061	0,86	93,3	93,3	92,5	6,6	2,2	1,8	0,6	2,8	3,09	860
132	GMM 315 L 6d	990	240	1273,2	0,85	93,5	93,5	93	7,2	2,4	2,5	0,8	3,2	3,4	1100
160	GMM 315 L 6e	990	286	1547,4	0,86	93,8	94,8	95,4	6	2	1,8	0,6	2,3	3,83	1160

3 Phase, 400 V, 50 Hz, IE1



Duty Type
S1 (Continuous Operation)



Protection Class
IP 55



Insulation Class
F (155°C) - H(180°C)



Temperature Rise
B (80 K)



Rated Power kW	Type	At Rated Power							At Starting				Breakdown Torque Ratio	Moment of Inertia	Approx Weight
		Speed RPM	Current A	Torque Nm	Power Coefficient Cos φ	Efficiency η			Current Ratio		Torque Ratio				
						4/4	3/4	1/2	Direct	Y/Δ	Direct	Y/Δ			

Cast Iron Frame / 8 poles - 750 RPM

2,2	GMEL 132 S 8a	690	5,85	31,05	0,73	74,2	74,2	74	3,5	1,2	1,9	0,6	3,2	0,029	51
3	GMEL 132 M 8b	690	7,8	41,5	0,72	77	79,1	77,3	3,7	1,2	2,3	1,2	2,4	0,032	61
4	GMEL 160 M 8a	700	10,4	54,5	0,70	79,2	79,1	77,4	3,4	1,1	1,5	0,5	2	0,06	71
5,5	GMEL 160 M 8b	710	15	76	0,65	81,4	80,3	77,5	4	1,3	2,3	0,7	2,6	0,095	102
7,5	GMEL 160 L 8c	710	19,3	100,9	0,68	83,1	82,2	81,7	4,1	1,4	2,4	0,8	2,6	0,17	124
11	GMEL 180 L 8a	715	26,2	148,6	0,71	85	86,7	85,4	4,4	1,5	2,1	0,7	2,6	0,2	147
15	GMEL 200 L 8a	720	32,5	199,8	0,77	86,2	87,7	87,2	4,6	1,5	1,7	0,6	2,3	0,36	221
18,5	GMEL 225 S 8a	735	39,4	285,35	0,78	86,9	86,9	86,5	6,3	2,1	1,7	0,6	1,9	0,48	257
22	GMEL 225 M 8b	740	44	239,1	0,83	87,4	87,4	86,8	5,82	1,94	1,67	0,55	2,35	0,52	272
30	GM 250 M 8a	735	59	389,8	0,82	88,3	88,3	87,2	6,1	2	1,8	0,6	2,6	0,92	383
37	GM 280 S 8a	730	73,0	484	0,82	88,8	88,8	85,2	4,7	1,6	2	0,7	2	1,3	465
45	GM 280 M 8b	730	86	588,7	0,83	89,2	89,2	88,1	4,9	1,6	1,9	0,6	1,8	1,6	508
55	GM 315 S 8a	740	110	709,8	0,77	89,7	89,7	88,6	5,7	1,9	1,8	0,6	1,99	2	708
75	GM 315 M 8b	740	153	967,9	0,76	90,3	90,3	89,1	5,9	2	1,9	0,6	2	2,5	745
90	GM 315 M 8c	740	180	1161,5	0,77	90,7	90,7	89,6	6,2	2,1	1,9	0,6	2	3	820
110	GMM 315 L 8d	740	209	1419,6	0,82	91,1	91,1	90	6,5	2,2	1,9	0,6	2	4	860
132	GMM 315 L 8e	740	262	1703,5	0,78	91,5	91,5	90,4	6	2	1,9	0,6	2	4,3	980
132	GMM 355 M 8a	740	290	1703,5	0,73	91,5	91,5	90,6	5,7	1,9	1,9	0,6	2	4,3	1222
160	GMM 355 M 8b	740	320	2064,9	0,76	91,9	91,9	91	5,9	2	1,9	0,6	2	8,9	1328
200	GMM 355 M 8c	740	420	2581,1	0,73	92,5	92,5	91,8	6,2	2,1	1,9	0,6	2	11	1590
250	GMM 355 L 8d	740	475	3226,4	0,7	92,5	92,5	91,9	6,5	2,2	1,9	0,6	2	13	2020
315	GMM 400 L 8a	745	650	4037,9	0,76	92,5	92,5	92	5,9	2	1,8	0,6	2,3	24,5	2555
355	GMM 400 L 8b	745	735	4550,7	0,73	92,5	92,5	92	6	2	1,8	0,6	2,3	26,6	2685
400	GMM 400 L 8c	745	845	5127,5	0,75	92,5	92,5	92	6,1	2	1,8	0,6	2,4	29	2835
450	GMM 400 L 8d	745	914	5768,5	0,75	92,5	92,5	92	6,2	2,1	1,8	0,6	2,5	32	3010

3 Phase, 400 V, 50 Hz, IE2



Duty Type
S1 (Continuous Operation)



Protection Class
IP 55



Insulation Class
F (155°C) - H(180°C)



Temperature Rise
B (80 K)



Rated Power	Type	At Rated Power							At Starting				Breakdown Torque Ratio	Moment of Inertia	Approx Weight
		Speed	Current	Torque	Power Coefficient	Efficiency η			Current Ratio		Torque Ratio				
kW		RPM	A	Nm	Cos ϕ	4/4	3/4	1/2	Direct	Y/ Δ	Direct	Y/ Δ			

Cast Iron Frame / 2 poles - 3000 RPM

5,5	GM2EL 132 S 2a	2905	9,85	18,1	0,93	87	87	86,5	6,5	2,1	2,2	0,7	2,5	0,013	45
7,5	GM2EL 132 S 2b	2910	13,6	24,6	0,90	88,1	88,1	87,9	7,2	2,3	2,8	0,9	3	0,014	64,5
11	GM2EL 160 M 2a	2945	19,33	35,7	0,92	89,4	89,4	88,6	6,6	2,1	2	0,6	2,6	0,027	105
15	GM2EL 160 M 2b	2945	26,1	48,6	0,92	90,3	90,3	89,7	7,2	2,3	2,1	0,7	2,8	0,035	117
18,5	GM2EL 160 L 2c	2950	32,3	59,9	0,91	90,9	90,8	90,1	7,7	2,5	2,5	0,8	3	0,043	135
22	GM2EL 180 M 2a	2950	38,3	71,2	0,91	91,3	91,3	90,8	8,2	2,6	3	1	3,5	0,066	158
30	GM2EL 200 L 2a	2970	52,0	96,5	0,91	92,0	92,0	91,2	8,3	2,7	2,7	0,9	3	0,13	190
37	GM2EL 200 L 2b	2970	65,0	119	0,89	92,5	92,5	91,7	8,3	2,7	2,7	0,9	3	0,15	220
45	GM2EL 225 M 2a	2975	75,0	144,5	0,93	92,9	93,0	91,8	8	2,6	2,4	0,8	2,9	0,23	375
55	GM2E 250 M 2a	2980	94,0	176,3	0,91	93,20	93,70	92,20	7,6	2,5	2,6	0,9	2,7	0,41	445
75	GM2E 280 S 2a	2980	128	240,4	0,91	93,80	94,00	92,50	7,0	2,3	2,4	0,8	2,5	0,53	512
90	GM2E 280 M 2b	2980	152	288,4	0,91	94,10	94,10	92,70	8,5	2,8	2,7	0,9	3,0	0,62	585
110	GM2E 315 S 2a	2980	192	352,5	0,88	94,30	94,30	92,80	7,0	2,3	2,5	0,8	3,0	1	675
132	GM2E 315 M 2b	2980	224	423,0	0,90	94,60	94,50	92,90	8,0	2,7	2,5	0,8	3,0	1,2	742
160	GM2E 315 M 2c	2980	266	512,8	0,92	94,80	94,80	93,40	7,8	2,6	2,5	0,8	3,2	1,4	812
185	GMM2E 315 L 2d	2980	307	592,9	0,92	95,00	95,00	93,60	8,0	2,7	2,5	0,8	3,0	1,5	912
200	GMM2E 315 L 2e	2980	330,00	640,9	0,92	95,00	95,00	93,60	8,0	2,7	2,5	0,8	3,0	1,5	912
250	GMM2E 355 M 2a	2980	420,00	801,2	0,90	95,00	95,00	93,60	8,0	2,7	2,0	0,7	2,3	3,3	1170
315	GMM2E 355 M 2b	2980	530,00	1009,5	0,90	95,00	95,00	93,70	8,0	2,7	2,0	0,7	2,3	4,1	1300
355	GMM2E 355 M 2c	2980	600,00	1137,7	0,90	95,00	95,00	93,80	8,0	2,7	2,0	0,7	2,3	4,5	1360
400	GMM2E 355 L 2d	2980	670,0	1281,9	0,91	95,00	95,00	93,80	8,0	2,7	2,0	0,7	2,3	4,7	1520

3 Phase, 400 V, 50 Hz, IE2



Duty Type
S1 (Continuous Operation)



Protection Class
IP 55



Insulation Class
F (155°C) - H(180°C)



Temperature Rise
B (80 K)



Rated Power	Type	At Rated Power							At Starting				Breakdown Torque Ratio	Moment of Inertia	Approx Weight
		Speed	Current	Torque	Power Coefficient	Efficiency η			Current Ratio		Torque Ratio				
kW		RPM	A	Nm	Cos ϕ	4/4	3/4	1/2	Direct	Y/ Δ	Direct	Y/ Δ			

Cast Iron Frame / 4 poles - 1500 RPM

5,5	GM2EL 132 S 4a	1465	11,2	35,9	0,81	87,7	87,7	87,2	7	2,3	2,8	0,9	3,5	0,021	48
7,5	GM2EL 132 M 4b	1465	15,4	48,9	0,79	88,7	88,8	88,1	7,1	2,3	2,7	0,9	3,4	0,026	56
11	GM2EL 160 M 4a	1460	21,6	72	0,82	89,8	89,9	89,3	6,8	2,2	2,4	0,8	3	0,061	113
15	GM2EL 160 L 4b	1470	29,4	97,4	0,81	90,6	90,7	89,7	7,4	2,4	2,8	0,9	3,2	0,082	132
18,5	GM2EL 180 M 4a	1470	34,5	120,2	0,85	91,2	91,4	90,4	7,7	2,5	3,2	1	3,4	0,13	165
22	GM2EL 180 L 4b	1470	42,5	142,9	0,82	91,6	91,6	90,6	8,3	2,7	2,7	0,9	3,8	0,15	180
30	GM2EL 200 L 4a	1470	53,52	194,9	0,88	92,3	92,3	92,1	7,8	2,5	2,8	0,9	2,8	0,227	232
37	GM2EL 225 S 4a	1470	67,0	240,4	0,86	92,7	92,7	92,2	7,2	2,3	3	1	3	0,3	355
45	GM2EL 225 M 4b	1470	80,0	292,3	0,87	93,1	93,1	92,4	7,3	2,4	3	1	3	0,36	375
55	GM2E 250 M 4a	1475	96,8	356,1	0,88	93,5	93,6	93,2	7,6	2,5	3,1	1,0	2,9	0,72	420
75	GM2E 280 S 4a	1480	133	484,0	0,87	94	94,1	93,4	7,0	2,3	2,6	0,9	2,8	0,96	550
90	GM2E 280 M 4b	1480	158	580,7	0,87	94,2	94,5	93,8	7,4	2,5	2,9	1,0	3,0	1,15	615
110	GM2E 315 S 4a	1485	195	707,4	0,86	94,5	94,5	93,8	7,4	2,5	2,0	0,7	3,0	2,1	784
132	GM2E 315 M 4b	1485	230	848,9	0,87	94,7	94,5	93,8	7,4	2,5	2,1	0,7	3,0	2,5	861
160	GM2E 315 M 4c	1485	280	1029,0	0,87	94,9	94,9	94,0	7,0	2,3	2,0	0,7	2,9	2,8	882
185	GMM2E 315 L 4d	1485	323	1189,7	0,87	95,1	95,1	94,2	7,4	2,5	2,2	0,7	3,0	2,9	962
200	GMM2E 315 L 4e	1485	350	1286,2	0,87	95,1	95,4	94,2	8,0	2,7	2,5	0,8	3,0	3,1	1015
250	GM2E 315 H 4f	1485	455	1607,1	0,83	95,1	95,1	94,5	8,1	2,7	2,3	0,8	3,0	3,5	1070
250	GMM2E 355 M 4a	1485	445	1607,7	0,85	95,1	95,1	94,2	6,4	2,1	2,1	0,7	2,8	5,5	1378
315	GMM2E 355 M 4b	1490	560	2019	0,85	95,1	95,1	94,5	6,4	2,1	2,0	0,7	2,8	6,0	1400
355	GMM2E 355 M 4c	1490	630	2275,3	0,86	95,1	95,4	94,2	7,0	2,3	2,0	0,7	2,8	6,5	1438
400	GMM2E 355 L 4d	1490	710	2563,8	0,86	95,1	95,1	94,5	7,0	2,3	2,0	0,7	2,8	7,2	1639

3 Phase, 400 V, 50 Hz, IE2



Duty Type
S1 (Continuous Operation)



Protection Class
IP 55



Insulation Class
F (155°C) - H(180°C)



Temperature Rise
B (80 K)



Rated Power	Type	At Rated Power							At Starting				Breakdown Torque Ratio	Moment of Inertia	Approx Weight
		Speed	Current	Torque	Power Coefficient	Efficiency η			Current Ratio		Torque Ratio				
kW		RPM	A	Nm	cos ϕ	4/4	3/4	1/2	Direct	Y/ Δ	Direct	Y/ Δ			

Cast Iron Frame / 6 poles - 1000 RPM

3	GM2EL 132 S 6a	960	7,1	29,8	0,74	83,3	83,2	80,4	4,6	1,5	1,8	0,6	2,3	0,019	50
4	GM2EL 132 M 6b	960	9,3	39,8	0,73	84,6	84,5	81,6	4,7	1,5	2	0,6	2,5	0,024	60
5,5	GM2EL 132 M 6c	960	12,7	54,7	0,73	86,0	86,0	83,1	4,9	1,6	2,2	0,7	2,6	0,032	70
7,5	GM2EL 160 M 6a	975	16,0	73,5	0,78	87,2	87,2	84,5	6,3	2	2,6	0,8	3,5	0,076	105
11	GM2EL 160 L 6b	970	22,5	108,3	0,80	88,7	88,7	85,7	6,2	2	3	1	3	0,109	133
15	GM2EL 180 L 6a	965	29,0	148,4	0,83	89,7	89,7	86,8	6,5	2,1	2,4	0,8	3	0,2	186
18,5	GM2EL 200 L 6a	980	37,1	180,3	0,80	90,4	90,4	87,7	7,2	2,3	2,3	0,7	3,2	0,234	203
22	GM2EL 200 L 6b	980	43,4	214,4	0,80	90,9	90,9	88,4	6,7	2,3	2,3	0,7	2,8	0,283	231
30	GM2EL 225 M 6a	980	58,0	292,3	0,81	91,7	91,7	89,6	7	2,3	3	1	2,6	0,57	330
37	GM2E 250 M 6a	985	71,4	358,7	0,81	92,20	92,2	90,1	7,0	2,3	3,0	1,0	2,6	0,77	380
45	GM2E 280 S 6a	985	92,0	436,3	0,76	92,70	92,7	90,9	7,0	2,3	3,3	1,1	2,6	1,2	500
55	GM2E 280 M 6b	985	107	533,2	0,80	93,10	93,1	91,5	7,0	2,3	3,3	1,1	2,6	1,5	553
75	GM2E 315 S 6a	990	139	723,5	0,83	93,70	93,7	92,4	7,0	2,3	2,0	0,7	3,0	2,4	727
90	GM2E 315 M 6b	990	166	868,2	0,83	94,00	94,0	92,6	7,0	2,3	2,0	0,7	3,0	2,9	805
110	GM2E 315 M 6c	990	198	1061,1	0,85	94,30	94,3	92,7	7,0	2,3	2,0	0,7	3,0	3,5	860
132	GMM2E 315 L 6d	990	237	1273,3	0,85	94,60	94,6	93,0	7,0	2,3	2,3	0,8	3,0	3,6	1020
160	GMM2E 315 L 6e	990	290	1543,4	0,84	94,80	94,8	93,2	7,0	2,3	2,3	0,8	3,0	4,2	1120
160	GMM2E 355 M 6a	990	305	1543,4	0,80	94,80	94,8	93,2	7,0	2,3	2,5	0,8	2,4	6,8	1035
200	GMM2E 355 M 6b	990	380	1929,3	0,80	95	95	93,5	7,0	2,3	2,5	0,8	2,4	6,8	1185
250	GMM2E 355 M 6c	990	470	2411,6	0,81	95	95	93,5	7,0	2,3	2,5	0,8	2,4	8,3	1390
315	GMM2E 355 L 6d	990	580	3038,6	0,83	95	95	93,5	7,0	2,3	2,5	0,8	2,4	10,7	1746
355	GMM2E 355 L 6e	990	650	3424,5	0,83	95	95	93,5	7,0	2,3	2,5	0,8	2,4	11,7	1890
355	GMM2E 400 L 6a	995	655	3407,3	0,82	95	95	93,5	7,0	2,3	2,0	0,7	2,6	19,6	2250
400	GMM2E 400 L 6b	995	740	3839,2	0,82	95	95	93,5	7,0	2,3	2,0	0,7	2,6	24,5	2575

3 Phase, 400 V, 50 Hz, IE3



Duty Type
S1 (Continuous Operation)



Protection Class
IP 55



Insulation Class
F (155°C) - H(180°C)



Temperature Rise
B (80 K)



Rated Power	Type	At Rated Power							At Starting				Breakdown Torque Ratio	Moment of Inertia	Approx Weight
		Speed	Current	Torque	Power Coefficient	Efficiency η			Current Ratio		Torque Ratio				
kW		RPM	A	Nm	Cos ϕ	4/4	3/4	1/2	Direct	Y/ Δ	Direct	Y/ Δ			

Cast Iron Frame / 2 poles - 3000 RPM

5,5	GM3EL 132 S 2a	2925	10,2	18	0,87	89,2	89,0	87,4	7,2	2,3	2,1	0,7	3	0,015	66,5
7,5	GM3EL 132 M 2b	2925	13,5	24,5	0,93	90,1	90,1	89,5	7,6	2,5	2,6	0,85	3,3	0,021	80,4
11	GM3EL 160 M 2a	2950	19,8	35,7	0,92	91,2	91,2	90,4	7,2	2,3	2,2	0,6	3	0,031	113
15	GM3EL 160 M 2b	2955	25,7	48,5	0,92	91,9	91,8	91,2	7,9	2,5	2,2	0,7	2,9	0,041	128
18,5	GM3EL 160 L 2c	2960	31,4	59,7	0,92	92,4	92,5	92,0	8,1	2,6	2,2	0,7	3,1	0,049	145
22	GM3EL 180 M 2a	2960	36,9	71	0,93	92,7	92,6	92,2	8,5	2,7	2,9	0,9	3,4	0,091	193
30	GM3EL 200 L 2a	2955	51,8	96,9	0,9	93,3	93,4	92,9	7,5	2,5	2,5	0,8	3	0,116	210
37	GM3EL 200 L 2b	2980	63,0	118,6	0,90	93,7	93,7	93,1	8,3	2,7	2,8	0,9	3,1	0,17	240
45	GM3EL 225 M 2a	2975	78,3	144,6	0,89	94	93,9	93,1	8,0	2,7	2,7	0,9	3,0	0,26	400
55	GM3E 250 M 2a	2980	95	176,25	0,88	94,3	94,3	94	8,9	3	3	1	3,3	0,35	423
75	GM3E 280 S 2a	2985	127	239,9	0,90	94,7	94,6	94	8,0	2,7	2,9	1,0	3,2	0,62	585
90	GM3E 280 M 2b	2985	148	287,9	0,92	95	95	93,7	8,2	2,7	2,9	1,0	3,0	0,74	645
110	GM3E 315 S 2a	2985	186	351,9	0,90	95,2	95,2	94	8,0	2,7	2,5	0,8	3,0	1,2	742
132	GM3E 315 M 2b	2985	223	422,3	0,90	95,4	95,4	94,1	8,0	2,7	2,4	0,8	3,5	1,4	812
160	GM3E 315 M 2c	2985	265	511,9	0,91	95,6	95,6	94,2	8,0	2,7	2,5	0,8	3,0	1,5	912
185	GMM3E 315 L 2d	2985	304	591,9	0,92	95,8	95,7	94,2	7,5	2,5	2,5	0,8	2,8	1,8	1110
200	GMM3E 315 L 2e	2985	324	639,9	0,93	95,8	95,8	94,6	7,5	2,5	2,5	0,8	2,8	1,8	1110
250	GM3E 315 H 2f	2990	410	798,5	0,92	95,8	95,8	94,6	7,5	2,5	2,5	0,8	2,8	1,8	1200
250	GMM3E 355 M 2a	2990	413	798,5	0,91	95,8	95,8	94,6	7,0	2,3	2,0	0,7	2,5	3,6	1170
315	GMM3E 355 M 2b	2990	516	1006,1	0,92	95,8	95,8	94,7	7,0	2,3	2,0	0,7	2,5	4,5	1360
355	GMM3E 355 M 2c	2990	575	1133,9	0,93	95,8	95,7	94,8	7,2	2,4	2,0	0,7	2,5	4,7	1420
400	GMM3E 355 L 2d	2990	660	1277,6	0,92	95,8	95,8	94,9	7,0	2,3	2,0	0,7	2,5	5,3	1630
450	GMM3E 355 L 2e	2980	737	1442,1	0,92	95,8	95,8	94,6	7,0	2,3	2,0	0,7	2,6	5,6	1720
450	GMM3E 400 L 2a	2985	729	1439,7	0,93	95,8	95,8	94,7	7,0	2,3	1,5	0,5	2,2	7,42	2310
500	GMM3E 355 L 2f	2980	810	1602,3	0,93	95,8	95,8	94,6	7,0	2,3	2,0	0,7	2,6	6,13	1810
500	GMM3E 400 L 2b	2985	810	1599,7	0,93	95,8	95,8	94,7	7,0	2,3	1,5	0,5	2,2	8,3	2577
560	GMM3E 400 L 2c	2990	912	1788,6	0,92	95,8	95,8	95	7,0	2,3	1,5	0,5	2,2	9,2	2719
630	GMM3E 400 L 2d	2985	1010	2015,6	0,94	95,8	95,8	95,1	7,0	2,3	1,5	0,5	2,2	10,39	2959

3 Phase, 400 V, 50 Hz, IE3



Duty Type
S1 (Continuous Operation)



Protection Class
IP 55



Insulation Class
F (155°C) - H(180°C)



Temperature Rise
B (80 K)



Rated Power	Type	At Rated Power							At Starting				Breakdown Torque Ratio	Moment of Inertia	Approx Weight
		Speed	Current	Torque	Power Coefficient	Efficiency η			Current Ratio		Torque Ratio				
kW		RPM	A	Nm	Cos ϕ	4/4	3/4	1/2	Direct	Y/ Δ	Direct	Y/ Δ			

Cast Iron Frame / 4 poles - 1500 RPM

5,5	GM3EL 132 S 4a	1450	11,0	36,2	0,81	89,6	89,6	88,8	6,0	2,0	2,4	0,9	3,0	0,026	48
7,5	GM3EL 132 M 4b	1450	15,1	49,3	0,8	90,4	90,5	89,6	5,9	2,0	2,5	0,9	2,8	0,032	56
11	GM3EL 160 M 4a	1470	21,1	71,5	0,82	91,4	91,3	91,0	6,1	2,0	1,9	0,6	2,6	0,076	124
15	GM3EL 160 L 4b	1475	29,7	97,1	0,79	92,1	92,0	91,8	7,5	2,5	2,5	0,9	3,3	0,0102	151
18,5	GM3EL 180 M 4a	1474	34,4	119,9	0,86	92,6	92,3	91,4	8,4	2,8	2,75	0,92	3,7	0,17	166
22	GM3EL 180 L 4b	1475	40,1	142,5	0,86	93	92,5	91,8	8	2,7	2,7	0,9	3,4	0,17	192
30	GM3EL 200 L 4a	1475	52,8	194,2	0,88	93,6	93,5	93,0	8,2	2,6	2,4	0,8	3,0	0,264	273
37	GM3EL 225 S 4a	1475	67,0	239,6	0,85	93,9	93,9	93,5	7,5	2,4	3,1	1,0	3,3	0,36	350
45	GM3EL 225 M 4b	1480	80,2	290,5	0,86	94,2	94,3	94	8,0	2,7	3,4	1,1	3,1	0,44	380
55	GM3E 250 M 4a	1480	96,0	354,9	0,87	94,6	94,7	94	7,7	2,6	3,2	1,1	3,0	0,72	420
75	GM3E 280 S 4a	1485	134,1	483,9	0,85	95	95,4	95	7,3	2,4	2,8	0,9	3,0	1,11	605
90	GM3E 280 M 4b	1485	160,6	577,9	0,85	95,2	95,4	94,9	7,5	2,5	2,7	0,9	2,9	1,32	665
110	GM3E 315 S 4a	1484	199	707,8	0,84	95,4	95,2	95	7,4	2,5	2,2	0,7	3,4	1,67	876
132	GM3E 315 M 4b	1485	232	850	0,86	95,6	95,4	95,3	8,2	2,7	2,5	0,8	3,5	2	1032
160	GM3E 315 L 4c	1485	277	1027	0,87	95,8	95,6	95,6	7,3	2,4	2	0,7	3	2,34	1098
185	GMM3E 315 L 4d	1485	324	1190,5	0,86	96	96	95,8	8,1	2,7	2,4	0,8	3,5	2,54	1112
200	GMM3E 315 L 4e	1485	350	1284	0,86	96	95,8	95,8	7,8	2,6	2,5	0,8	3,3	2,81	1100
250	GM3E 315 H 4f	1485	423	1596	0,89	96	95,8	95,8	8	2,7	2,2	0,7	3,3	3,88	1299
250	GMM3E 355 M 4a	1489	465	1603,42	0,81	96	96	95,8	7	2,3	2,4	0,8	3,1	5	1378
315	GMM3E 355 M 4b	1490	580	2018	0,82	96	96	95,8	6,7	2,2	2,2	0,73	3	5,2	1556
355	GMM3E 355 M 4c	1490	655	2275,33	0,81	96	96	95,8	7,5	2,5	2,6	0,85	3,4	6,86	1720
400	GMM3E 355 L 4d	1490	730	2563,75	0,82	96	96	95,8	7,5	2,5	2,6	0,85	3,4	7,1	1833
450	GMM3E 355 L 4e	1490	805	2884,22	0,84	96	96	95,8	6,5	2,2	2,2	0,73	3	9	-
450	GMM3E 400 L 4a	1490	770	2884,2	0,88	96	96	95	7,0	2,3	1,9	0,6	2,6	15,26	2425
500	GMM3E 400 L 4b	1490	849	3204,7	0,89	96	96	95	6,4	2,1	1,8	0,6	2,6	17,28	2530
560	GMM3E 400 L 4c	1490	975	3589,3	0,87	96	96	95	7,0	2,3	1,9	0,6	2,6	20,41	2801
630	GMM3E 400 L 4d	1490	1090	4037,9	0,87	96	96	95	7,2	2,4	2,0	0,7	2,8	21,3	2814
710	GMM3E 400 L 4e	1495	1228	4535,5	0,87	96	96	95,2	7,2	2,4	2,0	0,7	3,0	23,8	3055

3 Phase, 400 V, 50 Hz, IE3



Duty Type
S1 (Continuous Operation)



Protection Class
IP 55



Insulation Class
F (155°C) - H(180°C)



Temperature Rise
B (80 K)



Rated Power	Type	At Rated Power							At Starting				Breakdown Torque Ratio	Moment of Inertia	Approx Weight
		Speed	Current	Torque	Power Coefficient	Efficiency η			Current Ratio		Torque Ratio				
kW		RPM	A	Nm	Cos ϕ	4/4	3/4	1/2	Direct	Y/ Δ	Direct	Y/ Δ			

Cast Iron Frame / 6 poles - 1000 RPM

3	GM3EL 132 S 6a	970	7,3	29,5	0,69	85,6	85,6	85,2	5,4	1,7	2,1	0,7	2,9	0,023	53
4	GM3EL 132 M 6b	975	10,2	39,2	0,65	86,8	86,7	86,4	5,6	1,8	2,5	0,8	3,1	0,028	62
5,5	GM3EL 132 M 6c	975	13,7	53,9	0,66	88,0	87,8	87,5	5,9	1,9	2,6	0,8	3,3	0,036	71
7,5	GM3EL 160 M 6a	970	16,2	73,8	0,75	89,1	89,0	88,1	6,7	2,2	2,6	0,8	3,4	0,091	119
11	GM3EL 160 L 6b	975	24	107,7	0,77	90,3	90,3	89,0	7,6	2,5	3,0	1,0	3,8	0,13	145
15	GM3EL 180 L 6a	975	28,5	147	0,83	91,2	91,8	91,5	6,0	2,0	1,6	0,6	2,5	0,216	201
18,5	GM3EL 200 L 6a	980	37,5	180,3	0,78	91,7	91,6	91,3	7,9	2,5	2,6	0,9	3,7	0,289	236
22	GM3EL 200 L 6b	980	42,2	214,4	0,82	92,2	92,0	91,7	6,8	2,2	1,9	0,7	3,1	0,344	262
30	GM3EL 225 M 6a	985	58,0	290,9	0,80	92,9	92,9	92,1	7,0	2,3	3,3	1,1	2,7	0,69	350
37	GM3E 250 M 6a	985	70,0	358,7	0,82	93,3	93,2	92,9	7,0	2,3	2,8	0,9	2,6	0,77	380
45	GM3E 280 S 6a	990	88,0	434,1	0,79	93,7	93,7	92,9	6,9	2,3	3,0	1,0	2,8	1,5	553
55	GM3E 280 M 6b	990	112	530,6	0,75	94,1	94,1	92,8	7,3	2,4	3,3	1,1	3,2	1,7	578
75	GM3E 315 S 6a	990	140	723,5	0,82	94,6	94,6	94,4	7,2	2,4	2,7	0,9	3,0	2,9	805
90	GM3E 315 M 6b	990	166	868,2	0,82	94,9	94,9	94,5	7,2	2,4	2,7	0,9	3,0	3,5	860
110	GM3E 315 M 6c	990	198	1061,1	0,84	95,1	95,1	94,9	7,2	2,4	2,7	0,9	3,0	4,2	980
132	GMM3E 315 L 6d	990	235	1273,3	0,85	95,4	95,4	95,2	7,2	2,4	2,7	0,9	3,0	4,3	1150
160	GM3E 315 L 6e	990	291,1	1543,4	0,83	95,6	96,2	96	7,7	2,6	2,3	0,8	3,1	4,5	1200
160	GMM3E 355 M 6a	995	290	1535,7	0,83	95,6	95,6	95	7,0	2,3	2,4	0,8	3,2	6,8	1185
200	GMM3E 355 M 6b	995	345	1919,6	0,87	95,8	95,8	95,3	7,0	2,3	2,4	0,8	3,2	8,3	1390
250	GMM3E 355 L 6c	995	437	2399,5	0,86	95,8	95,8	95,4	7,0	2,3	2,4	0,8	3,2	10,4	1716
315	GMM3E 355 L 6d	995	555	3023,4	0,86	95,8	95,7	95,5	7,0	2,3	2,4	0,8	3,2	11,7	1890
355	GMM3E 400 L 6a	995	610	3407,3	0,88	95,8	95,8	95,7	6,8	2,3	2,2	0,7	2,9	23,6	2450
400	GMM3E 400 L 6b	995	690	3839,2	0,87	95,8	95,8	95,7	6,8	2,3	2,2	0,7	2,9	26,6	2705
450	GMM3E 400 L 6c	995	827	4319,1	0,82	95,8	95,8	94,8	6,5	2,2	1,8	0,6	2,6	28,64	2913
500	GMM3E 400 L 6d	995	900	4799	0,84	95,8	95,8	94,8	7,0	2,3	1,8	0,6	2,6	32	3130
560	GMM3E 400 L 6e	995	994	5374,9	0,85	95,8	95,8	95	7,0	2,3	1,8	0,6	2,6	33,41	3144

3 Phase, 400 V, 50 Hz, IE3



Duty Type
S1 (Continuous Operation)



Protection Class
IP 55



Insulation Class
F (155°C) - H(180°C)



Temperature Rise
B (80 K)



Rated Power	Type	At Rated Power							At Starting				Breakdown Torque Ratio	Moment of Inertia	Approx Weight
		Speed	Current	Torque	Power Coefficient	Efficiency η			Current Ratio		Torque Ratio				
kW		RPM	A	Nm	Cos ϕ	4/4	3/4	1/2	Direct	Y/ Δ	Direct	Y/ Δ			

Cast Iron Frame / 8 poles - 750 RPM

2,2	GM3EL 132 S 8a	705	5,2	29,8	0,75	81,9	81,2	81,1	4,5	1,5	2,4	0,8	2,7	0,029	51
3	GM3EL 132 M 8b	700	6,9	40,9	0,76	83,5	83,5	82,5	4,4	1,4	2,4	0,8	2,6	0,032	61
4	GM3EL 160 M 8a	710	9,2	53,8	0,74	84,8	84,8	83,8	4,3	1,4	1,8	0,6	2,3	0,06	89
5,5	GM3EL 160 M 8b	720	12,9	73	0,72	86,2	86,2	85,2	5,4	1,8	2,4	0,7	3,0	0,095	102
7,5	GM3EL 160 L 8c	720	17,65	99,5	0,7	87,3	87,3	86,3	1,9	0,6	2,1	0,7	2,2	0,17	124
11	GM3EL 180 L 8a	725	23,2	144,9	0,78	88,6	88,5	87,7	6,3	2,1	2,8	0,9	3,4	0,2	147
15	GM3EL 200 L 8a	725	31	197,6	0,78	89,6	89,6	88,6	6,1	2,0	2,3	0,8	3,1	0,36	221
18,5	GM3EL 225 S 8a	740	38,8	239,1	0,76	90,1	90,1	89,3	6,3	2,1	1,7	0,6	1,9	0,48	228
22	GM3EL 225 M 8b	735	44,1	285,35	0,8	90,6	90,6	89,6	5,8	1,9	1,7	0,6	2,4	0,52	232
30	GM3EL 250 M 8a	735	59	389,8	0,8	91,3	91,3	90,3	6,1	2	1,8	0,6	2,6	0,77	380
37	GM3E 280 S 8a	735	71,5	480,3	0,82	91,8	91,8	90,8	6,2	2,1	2,6	0,8	2,4	1,5	470
45	GM3E 280 M 8b	735	84,4	584	0,84	92,2	92,2	91,2	5,2	1,7	2,0	0,6	2,1	1,7	512
55	GM3E 315 S 8a	740	108	707	0,79	92,5	92,5	92,1	5,7	1,9	2,2	0,7	2,0	2	715
75	GM3E 315 M 8b	740	155,7	972	0,75	93,1	93,1	92,5	6,0	2,0	2,2	0,7	2,1	2,5	749
90	GM3E 315 M 8c	745	179,5	1156	0,77	93,4	93,4	92,4	6,5	2,2	2,7	0,9	2,3	3	825
110	GMM3E 315 L 8d	740	220,1	1414,9	0,77	93,7	93,7	92,7	5,9	2,0	2,6	0,8	2,1	4,2	875
132	GMM3E 315 L 8e	745	278	1692,1	0,73	94	94	93,4	5,7	1,9	2,3	0,7	2,2	4,4	1000
132	GMM3E 355 M 8a	740	289,6	1703,5	0,7	94	94	93	5,5	1,8	2,3	0,8	2,5	4,3	1000
160	GMM3E 355 M 8b	745	319	2051,01	0,77	94,3	94,3	93,3	5,5	1,9	1,8	0,6	2,3	4,3	1225
200	GMM3E 355 M 8c	740	433	2581,1	0,71	94,6	94,6	93,7	6,0	2,0	2,1	0,7	2,6	11	1600
250	GMM3E 355 L 8d	745	562	3204,7	0,81	94,6	94,6	93,8	6,5	2,2	1,9	0,6	2,0	13	2025
315	GMM3E 400 L 8a	740	650	4037,9	0,74	94,6	94,6	93,6	5,9	2,0	1,8	0,6	2,3	24,8	2560
355	GMM3E 400 L 8b	745	732,0	4550,7	0,74	94,6	94,6	93,6	6,0	2,0	1,8	0,6	2,3	26,6	2685
400	GMM3E 400 L 8c	745	840,00	5127,5	0,73	94,6	94,6	93,6	6,1	2,0	1,8	0,6	2,4	29	2835
450	GMM3E 400 L 8d	745	904	5768,5	0,76	94,6	94,6	93,6	6,2	2,1	1,8	0,6	2,5	33	3020

3 Phase, 400 V, 50 Hz, IE4



Duty Type
S1 (Continuous Operation)



Protection Class
IP 55



Insulation Class
F (155°C) - H(180°C)



Temperature Rise
B (80 K)



Rated Power	Type	At Rated Power							At Starting				Breakdown Torque Ratio	Moment of Inertia	Approx Weight
		Speed	Current	Torque	Power Coefficient	Efficiency η			Current Ratio		Torque Ratio				
kW		RPM	A	Nm	Cos ϕ	4/4	3/4	1/2	Direct	Y/ Δ	Direct	Y/ Δ			

Cast Iron Frame / 2 poles - 3000 RPM

5,5	GM4EL 132 S 2a	2930	9,9	17,9	0,88	90,9	89,9	88,7	6,7	2,2	2,6	0,9	3,5	0,013	45
7,5	GM4EL 132 M 2b	2930	12,3	24,4	0,96	91,7	91,5	91,5	7,4	2,5	2,2	0,7	3,0	0,021	80,4
11	GM4EL 160 M 2a	2950	17,5	35,6	0,98	92,6	92	91,3	7,6	2,5	2,0	0,7	2,9	0,035	117
15	GM4EL 160 L 2b	2960	25,5	48,4	0,91	93,3	93,1	92,3	9,1	3,0	2,5	0,8	3,4	0,043	135
18,5	GM4EL 160 L 2c	2955	31,3	59,6	0,91	93,7	93,9	93,9	8,5	2,8	2,3	0,8	3,2	0,043	135
22	GM4EL 180 M 2a	2950	36,1	70,9	0,94	94	93,8	93,9	8,8	2,9	2,7	0,9	3,5	0,066	158
30	GM4EL 200 L 2a	2965	50,2	96,5	0,91	94,5	94,5	93,8	8,8	2,9	3,1	1,0	3,4	0,17	240
37	GM4EL 200 H 2b	2970	61,9	119,1	0,91	94,8	94,8	94,2	8,7	2,9	3,1	1,0	3,2	0,581	267
45	GM4EL 225 M 2a	2975	74,4	144,4	0,92	95	95,16	94,65	8,5	2,8	2,8	0,9	3,0	0,67	400
55	GM4E 250 M 2a	2980	92	176,2	0,91	95,3	95,35	94,74	9,1	3,0	3,0	1,0	3,3	0,37	480
75	GM4E 280 S 2a	2980	126	240,3	0,9	95,6	95,5	94,7	9,1	3,0	3,2	1,1	3,1	0,56	585
90	GM4E 280 M 2b	2975	149	288,8	0,91	95,8	95,9	95,4	8,4	2,8	2,8	0,9	3,0	0,62	645
110	GM4E 315 S 2a	2975	192,3	353	0,86	96	95,67	94,58	8,1	2,7	2,5	0,8	3,7	0,93	742
132	GM4E 315 M 2b	2975	225,1	423,6	0,88	96,2	96,22	95,72	7,6	2,5	2,4	0,8	3,5	1,1	812
160	GM4E 315 M 2c	2980	266,5	512,7	0,9	96,3	96,29	95,75	8,1	2,7	2,3	0,8	3,5	1,31	912
185	GM4E 315 L 2d	2975	308	593,8	0,9	96,5	96,63	96,22	8,0	2,7	2,7	0,9	3,7	1,44	1110
200	GM4E 315 L 2e	2980	325,2	640,8	0,92	96,5	96,57	96,19	8,6	2,9	2,9	1,0	3,8	1,91	1110
250	GM4E 315 H 2f	2975	403	802,4	0,93	96,5	96,7	96,5	7,8	2,6	2,4	0,8	3,4	2,12	1200
250	GM4E 355 M 2a	2985	411	799,7	0,91	96,5	96,3	95,6	8,2	2,7	2,2	0,7	3,7	3,1	1170
400	GMM4E 355 L 2d	2985	651	1279,6	0,92	96,5	96,3	95,6	8,4	2,8	2,5	0,8	3,6	4,37	1630

3 Phase, 400 V, 50 Hz, IE4



Duty Type
S1 (Continuous Operation)



Protection Class
IP 55



Insulation Class
F (155°C) - H(180°C)



Temperature Rise
B (80 K)



Rated Power	Type	At Rated Power							At Starting				Breakdown Torque Ratio	Moment of Inertia	Approx Weight
		Speed	Current	Torque	Power Coefficient	Efficiency η			Current Ratio		Torque Ratio				
kW		RPM	A	Nm	cos ϕ	4/4	3/4	1/2	Direct	Y/ Δ	Direct	Y/ Δ			

Cast Iron Frame / 4 poles - 1500 RPM

7,5	GM4EL 160 M 4e	1480	15	48,4	0,78	92,6	92,2	90,9	9,1	3,0	3,1	1,0	4,1	0,076	110
11	GM4EL 160 H 4a	1480	22,4	70,9	0,77	93,3	92,7	91,4	8,0	2,7	3,0	1,0	4,2	0,102	150
15	GM4EL 180 M 4d	1475	26	97,1	0,89	93,9	93,6	93,3	8,7	2,9	2,7	0,9	3,4	0,190	208
18,5	GM4EL 180 M 4a	1480	33,2	119,4	0,85	94,2	93,7	93	9,3	3,1	3,2	1,1	4,0	0,192	215
22	GM4EL 180 L 4b	1475	39,2	142,3	0,86	94,5	94,1	93,6	8,4	2,8	2,7	0,9	3,6	0,228	147
30	GM4EL 200 H 4a	1480	52,9	193,9	0,86	94,9	94,8	94,4	9,4	3,1	3,4	1,1	3,9	0,581	267
37	GM4EL 225 S 4a	1480	64,5	238,7	0,87	95,2	95,2	94,8	8,7	2,9	3,6	1,2	3,4	0,6	350
45	GM4EL 225 M 4b	1480	79,2	290,3	0,86	95,4	95,4	95	9,2	3,1	3,8	1,3	3,6	0,67	380
55	GM4E 250 M 4a	1485	105,1	353,6	0,79	95,7	95,7	95	8,5	2,8	4,3	1,4	3,5	0,77	460
75	GM4E 280 S 4a	1485	134,3	482,2	0,84	96	96,19	95,89	8,4	2,8	3,3	1,1	3,5	1,25	605
90	GM4E 280 H 4b	1485	161	578,7	0,84	96,1	96,23	95,81	8,8	2,9	3,4	1,1	3,6	1,25	665
110	GM4E 315 S 4a	1485	194	707,8	0,85	96,3	96,2	96	7,9	2,6	2,2	0,7	3,5	1,94	880
132	GM4E 315 M 4b	1485	227	849,5	0,87	96,4	96,7	96,4	8,7	2,9	2,6	0,9	3,7	2,47	1034
160	GM4E 315 L 4c	1490	275	1026	0,87	96,6	96,7	96,4	8,6	2,9	2,3	0,8	3,5	3,08	1110
185	GM4E 315 L 4d	1490	318	1189	0,87	96,7	96,7	96,4	9	3	2,6	0,9	3,8	3,21	1015
200	GMM4E 315 L 4e	1490	344	1282	0,87	96,7	96,93	96,74	8,5	2,8	2,6	0,9	3,6	3,61	1100
250	GM4E 315 H 4f	1490	425	1595	0,88	96,7	96,6	96,1	9	3	2,6	0,9	3,7	4,21	1200
250	GM4E 355 M 4a	1490	440	1602,2	0,85	96,7	96,9	96,7	6,6	2,2	2,0	0,7	2,9	5,29	1400
315	GM4E 355 M 4b	1490	553	2018,8	0,85	96,7	96,8	96,2	7,6	2,5	2,4	0,8	3,2	7,78	1538
355	GMM4E 355 L 4c	1490	631	2275,2	0,84	96,7	96,7	96,2	8,3	2,8	2,6	0,9	3,6	8,23	1490
400	GMM4E 355 L 4d	1490	694	2563,5	0,86	96,7	96,9	96,5	7,1	2,4	2,2	0,7	3,0	7,9	1720

3 Phase, 400 V, 50 Hz, IE4



Duty Type
S1 (Continuous Operation)



Protection Class
IP 55



Insulation Class
F (155°C) - H(180°C)



Temperature Rise
B (80 K)



Rated Power	Type	At Rated Power							At Starting				Breakdown Torque Ratio	Moment of Inertia	Approx Weight
		Speed	Current	Torque	Power Coefficient	Efficiency η			Current Ratio		Torque Ratio				
kW		RPM	A	Nm	Cos ϕ	4/4	3/4	1/2	Direct	Y/ Δ	Direct	Y/ Δ			

Cast Iron Frame / 6 poles - 1000 RPM

3	GM4EL 132 S 6a	970	6,7	29,5	0,73	88,6	89,1	88,2	6,0	2	2,3	1,2	2,9	0,019	50
4	GM4EL 132 M 6b	970	9,5	39,2	0,68	89,5	88,7	87,1	6,4	2,1	2,8	0,9	3,4	0,024	60
5,5	GM4EL 132 M 6c	970	12,5	54,1	0,7	90,5	90,5	89	5,4	1,8	2,1	0,7	2,7	0,036	71
7,5	GM4EL 160 M 6a	980	15,6	73,4	0,76	91,3	90,8	89,9	7,5	2,5	2,6	0,9	3,7	0,061	113
15	GM4EL 180 L 6a	980	29,8	146,9	0,78	92,9	92,6	91,75	7,0	2,3	1,9	0,6	3,3	0,216	201
18,5	GM4EL 200 L 6a	980	37,3	181,1	0,77	93,4	93,3	92,4	8,3	2,8	2,4	0,8	4,1	0,227	232
22	GM4EL 200 H 6b	980	43,5	213,8	0,78	93,7	93,9	93,1	7,6	2,5	1,9	0,6	3,6	0,581	267
30	GM4EL 225 M 6a	990	57,5	289,3	0,8	94,2	94,36	93,7	7,1	2,4	3,1	1,0	2,7	0,85	400
37	GM4E 250 M 6a	990	70,7	356,8	0,8	94,5	94,66	93,96	7,5	2,5	3,3	1,1	2,9	1,04	440
45	GM4E 280 S 6a	990	86,8	434	0,79	94,8	94,8	94,1	6,1	2,0	2,2	0,7	2,5	1,25	553
55	GM4E 280 M 6b	990	105,7	530,5	0,79	95,1	95,1	94,4	6,8	2,3	2,3	0,8	2,8	1,57	578
75	GM4E 315 S 6a	990	144	723,4	0,79	95,4	95,54	94,67	7,7	2,6	2,4	0,8	3,3	2,34	805
90	GM4E 315 M 6b	990	169	868,1	0,8	95,6	95,75	95,34	7,4	2,5	2,1	0,7	3,0	2,88	860
110	GM4E 315 M 6c	990	210	1061	0,79	95,8	95,88	95,34	7,9	2,6	2,4	0,8	3,4	3,42	980
132	GM4E 315 L 6d	990	236,3	1273,2	0,84	96	96,24	96,07	6,9	2,3	1,8	0,6	2,8	3,78	1150
160	GM4E 315 L 6e	990	289,3	1543,3	0,83	96,2	96,2	95,8	7,6	2,5	2,3	0,8	3,0	4,5	1200
160	GM4E 355 M 6a	995	286	1535,5	0,84	96,2	96,23	95,7	8,0	2,7	2,1	0,7	3,0	7,32	1325
185	GM4E 355 M 6f	995	334	1775,4	0,83	96,3	96,38	95,9	7,2	2,4	2,1	0,7	2,8	7,69	1390
200	GM4E 355 M 6b	995	361	1919,4	0,83	96,3	96,3	95,8	7,7	2,6	2,2	0,7	3,2	8,24	1495
250	GM4E 355 L 6c	995	450	2399,3	0,83	96,5	96,5	96,1	7,5	2,5	2,0	0,7	3,1	10,8	1856
315	GM4E 355L 6d	995	561	3029,4	0,84	96,6	96,6	96,2	7,7	2,6	2,2	0,7	3	11,9	1950

3 Phase, 400 V, 50 Hz, IE4



Duty Type
S1 (Continuous Operation)



Protection Class
IP 55



Insulation Class
F (155°C) - H(180°C)



Temperature Rise
B (80 K)



Rated Power	Type	At Rated Power							At Starting				Breakdown Torque Ratio	Moment of Inertia	Approx Weight
		Speed	Current	Torque	Power Coefficient	Efficiency η			Current Ratio		Torque Ratio				
kW		RPM	A	Nm	Cos ϕ	4/4	3/4	1/2	Direct	Y/ Δ	Direct	Y/ Δ			
Cast Iron Frame / 8 poles - 750 RPM															
2,2	GM4EL 132 S 8a	710	5,9	29,8	0,64	84,5	82,6	80,2	4,5	1,5	2,6	0,9	3,0	0,019	50
3	GM4EL 132 M 8b	710	7,65	40,2	0,66	85,9	84,3	82,2	5,0	1,7	2,9	0,9	3,2	0,032	61
4	GM4EL 160 M 8a	720	10,3	53,2	0,64	87,1	85,7	83,6	4,8	1,6	2,2	0,7	2,9	0,061	113
5,5	GM4EL 160 M 8b	730	14	72,4	0,64	88,3	87,3	85,5	5,5	1,8	2,5	0,8	3,3	0,091	119
7,5	GM4EL 160 L 8c	730	17,9	99,5	0,68	89,3	88,6	87,1	5,8	1,9	2,3	0,8	3,3	0,124	162
11	GM4EL 180 L 8a	730	23,1	144,7	0,76	90,4	90,7	90	6,7	2,2	3,0	1,0	3,6	0,216	201
15	GM4EL 200 L 8a	730	34,9	195,9	0,68	91,2	89,9	88,3	6,0	2,0	2,5	0,8	3,5	0,227	232
55	GM4E 315 S 8a	740	108,6	709,7	0,78	93,7	93,7	93	5,8	1,9	2,3	0,8	2,0	2,84	715
75	GM4E 315 M 8b	740	153,3	967,8	0,75	94,2	94,4	93,65	4,7	1,6	1,9	0,6	1,9	3,56	749
90	GM4E 315 M 8c	745	176,5	1153,6	0,78	94,4	94,4	93,7	6,0	2,0	2,4	0,8	2,1	4,27	825
110	GM4E 315 L 8d	740	220,7	1419,4	0,76	94,7	95	94,63	4,7	1,6	1,6	0,5	2,0	5,34	875
132	GM4E 315 L 8e	745	257,5	1691,9	0,78	94,9	94,9	94,2	5,9	2,0	2,4	0,8	2,0	6,17	1000



3 PHASE COMPACT ASYNCHRONOUS MOTORS

Gamak has been strengthening the Turkish industry since 1961 and stands out with its 3-phase asynchronous motor solutions that combine compact structure with high performance. Our compact range is specially designed for spacesaving applications, offering high performance and durability despite their small size.

3 Phase Compact Asynchronous Motors Features

Power Range	0,25-110 kW
Pole	2, 4 and 6
Efficiency	IE1, IE2, IE3, IE4
Frame	80-280 Frame
Protection Class	Aluminum (80-250) and Cast Iron (132-280)
Insulation Class	IP55 (Options on request IP56, IP65, IP66)
Cooling Type	F(155°C), H(180°C)
Installation Arrangement	IC 411 (Totally enclosed fan cooled) B3, B5, B14, B34, B35, B14-2, B34-2

Compact 3 phase asynchronous motors are widely used in many industrial areas such as machine manufacturing, automation systems, fan and pump applications. Developed with Gamak's engineering power, these motors are manufactured in accordance with IEC standards and operate safely even in harsh conditions with IP55 protection class and F insulation class.

Gamak compact motor series are lightweight and durable with aluminum and cast iron frame options. With a wide range of power and speed options, these motors are both practical and economical solutions for businesses with their ease of installation and maintenance-free structure.

Compact motors, which are offered with IE3 and IE4 class options in terms of energy efficiency, attract attention with their low operating costs as well as their environmentally friendly approach. Combined with Gamak's production quality and reliability, these compact motors guarantee long-lasting performance.

Turkey's motor powerhouse Gamak continues to add value to your projects with its compact motor solutions. For those looking for more power in less space, Gamak compact induction motors are the right choice!



**POWER
TO
ENERGIZE
LIFE**

3 Phase, 400 V, 50 Hz, IE1-IE2



Duty Type
S1 (Continuous Operation)



Protection Class
IP 55



Insulation Class
F (155°C)



Temperature Rise
B (80 K)



Rated Power	Type	At Rated Power							At Starting				Breakdown Torque Ratio	Moment of Inertia	Approx Weight
		Speed	Current	Torque	Power Coefficient	Efficiency η			Current Ratio		Torque Ratio				
kW		RPM	A	Nm	Cos ϕ	4/4	3/4	1/2	Direct	Y/ Δ	Direct	Y/ Δ			

Aluminum Frame / 2 poles - 3000 RPM

0,37	C.AGM2E 63 M 2c	2850	1,05	1,20	0,73	69,50	69,50	68,00	5,0	-	2,5	-	2,7	0,00018	4,7
0,75	C.AGMEL 71 M 2c	2785	1,75	2,6	0,80	72,1	78,5	76,4	4,4	-	2,5	-	2,8	0,00034	6
0,75	C.AGM2EL 71 M 2c	2785	1,75	2,6	0,80	77,4	78,5	76,4	4,4	-	2,5	-	2,8	0,00034	6
1,5	C.AGMEL 80 M 2c	2850	3,4	5,0	0,81	77,2	80,3	78,1	4,9	-	2,2	-	2,9	0,001	10,4
1,5	C.AGMEL 80 M 2c	2850	3,4	5,0	0,81	77,2	80,3	78,1	4,9	-	2,2	-	2,9	0,001	10,4
3	C.AGM2EL 90 L 2c	2845	5,9	10,1	0,87	84,6	84,6	84	5,6	-	2,3	-	2,6	0,0019	18,1
3	C.AGMEL 90 L 2c	2845	5,9	10,1	0,9	81,5	81,5	80	5,6	-	2,3	-	2,6	0,0019	18,1
4	C.AGMEL 100 L 2b	2845	7,8	13,4	0,89	83,1	84,2	83,9	5,4	1,8	1,9	0,6	2,5	0,0031	22,5
4	C.AGM2EL 100 L 2b	2880	7,90	13,3	0,84	86,6	86,5	86,0	7,2	2,3	2,8	0,9	3	0,0031	22,5
5,5	C.AGMEL 112 M 2b	2900	10,3	18,1	0,91	84,7	84,7	83	7	2,3	2,4	0,8	3,3	0,007	19,2
5,5	C.AGM2EL 112 M 2b	2905	9,90	18,1	0,92	87,0	87,0	86,5	6,2	2	2	0,6	2,5	0,0045	28,2
7,5	C.AGMEL 112 M 2c	2895	14	24,7	0,90	86	86	85	7	2,3	2,4	0,8	3,3	0,0045	28,2
7,5	C.AGM2EL 112 H 2c	2910	13,6	24,6	0,91	88,1	88,1	87,5	6,2	2	2	0,6	2,5	0,0062	29,5
9,2	C.AGMEL 132 S 2c	2915	16,6	30,1	0,90	86,8	89,4	89	6,8	2,3	2,1	0,7	3	0,018	55
9,2	C.AGM2EL 132 S 2c	2915	16,6	30,1	0,90	86,8	89,4	89	6,8	2,3	2,1	0,7	3	0,018	55
11	C.AGMEL 132 M 2d	2920	19,9	36	0,91	87,6	87,6	85,5	7,5	2,5	2,4	0,8	3,2	0,021	63
11	C.AGM2EL 132 M 2d	2945	19,4	35,7	0,91	89,4	89,4	88,6	6,5	2,1	2,1	0,7	2,6	0,021	63
22	C.AGMEL 160 L 2d	2945	37,9	71,3	0,93	89,9	89,9	89,8	7,1	2,4	1,8	0,6	2,7	0,1	115
22	C.AGM2EL 160 L 2d	2950	38,0	71,2	0,92	91,3	91,3	90,8	7,1	2,3	2,3	0,7	2,9	0,05	120
30	C.AGMEL 180 L 2b	2960	55,3	96,7	0,86	90,7	90,7	90,5	9,2	3,1	2,8	0,9	4	0,09	157
30	C.AGM2EL 180 L 2b	2970	52,0	96,5	0,91	92,0	92,0	91,2	8,3	2,7	2,7	0,9	3	0,09	157
45	C.AGMEL 200 L 2c	2960	77,7	145,2	0,91	91,7	91,7	90	8	2,6	2,7	0,9	2,9	0,23	191
45	C.AGM2EL 200 L 2c	2975	77,0	144,5	0,91	92,9	93,0	91,8	8	2,6	2,7	0,9	2,9	0,23	191
55	C.AGM2EL 225 M 2b	2980	94,0	176,3	0,91	93,2	93,2	92,2	7,6	2,5	2,6	0,8	2,7	0,41	430

C.AGME(L): IE1 efficiency class
C.AGM2E(L): IE2 efficiency class

3 Phase, 400 V, 50 Hz, IE1-IE2



Duty Type
S1 (Continuous Operation)



Protection Class
IP 55



Insulation Class
F (155°C)



Temperature Rise
B (80 K)



Rated Power	Type	At Rated Power							At Starting				Breakdown Torque Ratio	Moment of Inertia	Approx Weight
		Speed	Current	Torque	Power Coefficient	Efficiency η			Current Ratio		Torque Ratio				
kW		RPM	A	Nm	Cos ϕ	4/4	3/4	1/2	Direct	Y/ Δ	Direct	Y/ Δ			

Aluminum Frame / 4 poles - 1500 RPM

0,25	C.AGM 63 M 4c	1350	0,95	1,8	0,63	60,70	60,70	56,80	3,0	-	2,0	-	2,0	0,00026	4,5
0,55	C.AGMEL 71 M 4c	1385	1,6	3,8	0,75	68,6	68,6	67,6	3,4	-	1,9	-	2,1	0,00062	6,4
1,1	C.AGMEL 80 M 4c	1395	2,9	7,5	0,73	75	76	73,6	3,8	-	1,9	-	2,2	0,00066	8,8
1,1	C.AGM2EL 80 H 4c	1415	2,8	7,4	0,7	81,4	81,4	80	4,5	1,5	2,5	0,8	2,8	0,0019	11,2
2,2	C.AGMEL 90 L 4c	1420	5	14,8	0,8	79,7	82,5	80,9	4,9	-	2,2	-	2,6	0,0020	18,3
2,2	C.AGM2EL 90 H 4c	1420	5,1	14,8	0,74	84,3	84,3	82,5	5	-	2,2	-	2,6	0,004	18,1
4	C.AGMEL 100 L 4c	1420	8,7	26,9	0,80	83,1	84,7	84,1	5,1	1,7	2,2	0,7	2,6	0,0031	25
4	C.AGM2EL 100 H 4c	1440	8,50	26,5	0,78	86,6	86,7	85,3	6,6	2,1	2,5	0,8	3,3	0,0076	28,1
5,5	C.AGMEL 112 M 4b	1440	11,5	36,5	0,82	84,7	84,2	83	5,7	1,9	2,2	0,7	2,7	0,015	36
5,5	C.AGM2EL 112 M 4b	1465	11,3	35,9	0,80	87,7	88,0	87,2	7	2,3	2,8	0,9	3,5	0,015	36
9,2	C.AGMEL 132 M 4c	1445	19,4	60,8	0,80	86	87,4	86,7	5,1	1,7	2,2	0,7	2,5	0,031	70
9,2	C.AGM2EL 132 M 4c	1455	19,3	60,1	0,77	89,8	89,8	89,4	6,6	2,2	2,6	0,9	3,1	0,031	70
11	C.AGMEL 132 M 4d	1450	23,2	72,5	0,78	87,6	87,6	86,7	5,3	1,8	2,2	0,7	2,7	0,039	90
11	C.AGM2EL 132 M 4d	1450	22	72,4	0,80	89,8	89,9	89,3	6,8	2,2	2,4	0,8	3	0,039	90
18,5	C.AGMEL 160 L 4c	1460	36,6	121	0,82	89,3	89,2	89	6,3	2,1	2,1	0,7	2,9	0,1	115
18,5	C.AGM2EL 160 L 4c	1470	35,0	120,2	0,84	91,2	91,2	90,4	7,7	2,5	3,2	1	3,4	0,1	115
30	C.AGMEL 180 L 4c	1470	55	194,9	0,87	90,7	90,7	90,2	6,9	2,3	2,1	0,7	2,9	0,21	176
30	C.AGM2EL 180 L 4c	1470	53,7	194,9	0,87	92,3	92,3	92,1	7,8	2,5	2,8	0,9	2,8	0,21	176
37	C.AGMEL 200 L 4b	1465	70,3	240,9	0,83	91,2	91,2	90,2	6,8	2,3	2,5	0,8	3,1	0,23	191
37	C.AGM2EL 200 L 4b	1470	67,0	240,4	0,86	92,7	92,7	92,2	7,2	2,3	3	1	3	0,3	225
55	C.AGM2EL 225 M 4c	1475	96,0	356,1	0,88	93,5	93,5	93,2	7,6	2,5	3,1	1	2,9	0,72	405

C.AGME(L): IE1 efficiency class
 C.AGM2E(L): IE2 efficiency class

3 Phase, 400 V, 50 Hz, IE1-IE2



Duty Type
S1 (Continuous Operation)



Protection Class
IP 55



Insulation Class
F (155°C)



Temperature Rise
B (80 K)



Rated Power	Type	At Rated Power							At Starting				Breakdown Torque Ratio	Moment of Inertia	Approx Weight
		Speed	Current	Torque	Power Coefficient	Efficiency η			Current Ratio		Torque Ratio				
kW		RPM	A	Nm	Cos ϕ	4/4	3/4	1/2	Direct	Y/ Δ	Direct	Y/ Δ			

Cast Iron / 2 poles - 3000 RPM

9,2	C.GMEL 132 S 2c	2920	16,6	30,1	0,93	86	86	85	6,8	2,3	2,1	0,7	3	0,018	55
9,2	C.GM2EL 132 S 2c	2915	16,6	30,1	0,90	86,8	89,4	89	6,8	2,3	2,1	0,7	3	0,018	55
11	C.GMEL 132 M 2d	2920	19,9	36	0,91	87,6	87,6	85,5	7,5	2,5	2,4	0,8	3,2	0,030	79
11	C.GM2EL 132 M 2d	2945	19,4	35,7	0,91	89,4	89,4	88,6	6,5	2,1	2,1	0,7	2,6	0,021	63
22	C.GMEL 160 L 2d	2945	37,9	71,3	0,93	89,9	89,9	89,8	7,1	2,4	1,8	0,6	2,7	0,1	151
22	C.GM2EL 160 L 2d	2950	38,0	71,2	0,92	91,3	91,3	90,8	7,1	2,3	2,3	0,7	2,9	0,05	120
30	C.GMEL 180 L 2b	2960	55,3	96,7	0,86	90,7	90,7	90,5	9,2	3,1	2,8	0,9	4	0,09	193
30	C.GM2EL 180 L 2b	2970	52,0	96,5	0,91	92,0	92,0	91,2	8,3	2,7	2,7	0,9	3	0,09	157
45	C.GMEL 200 L 2c	2960	77,7	145,2	0,91	91,7	91,7	90	8	2,6	2,7	0,9	2,9	0,23	191
45	C.GM2EL 200 L 2c	2975	77,0	144,5	0,91	92,9	93,0	91,8	8	2,6	2,7	0,9	2,9	0,23	191
55	C.GM2EL 225 M 2b	2980	94,0	176,3	0,91	93,2	93,2	92,2	7,6	2,5	2,6	0,8	2,7	0,41	430

Cast Iron / 4 poles - 1500 RPM

9,2	C.GMEL 132 M 4c	1445	19,4	60,8	0,80	86	87,4	86,7	5,1	1,7	2,2	0,7	2,5	0,031	58
11	C.GMEL 132 M 4d	1450	23,2	72,5	0,78	87,6	87,6	86,7	5,3	1,8	2,2	0,7	2,7	0,039	90
11	C.GM2EL 132 M 4d	1450	22	72,4	0,80	89,8	89,9	89,3	6,8	2,2	2,4	0,8	3	0,039	90
18,5	C.GMEL 160 L 4c	1460	36,6	121	0,82	89,3	89,2	89	6,3	2,1	2,1	0,7	2,9	0,1	115
19,5	C.GM2EL 160 L 4c	1470	35,0	120,2	0,84	91,2	91,2	90,4	7,7	2,5	3,2	1	3,4	0,1	115
30	C.GMEL 180 L 4c	1470	55	194,9	0,87	90,7	90,7	90,2	6,9	2,3	2,1	0,7	2,9	0,21	176
30	C.GM2EL 180 L 4c	1470	53,7	194,9	0,87	92,3	92,3	92,1	7,8	2,5	2,8	0,9	2,8	0,21	176
37	C.GMEL 200 L 4b	1465	70,3	240,9	0,83	91,2	91,2	90,2	6,8	2,3	2,5	0,8	3,1	0,581	267
37	C.GM2EL 200 L 4b	1470	67,0	240,4	0,86	92,7	92,7	92,2	7,2	2,3	3	1	3	0,3	225
55	C.GM2EL 225 M 4c	1475	96,0	356,1	0,88	93,5	93,5	93,2	7,6	2,5	3,1	1	2,9	0,72	405
75	C.GM2E 250 M 4b	1475	132	485,6	0,87	94,0	94,0	93,2	7,5	2,5	3,1	1,1	2,7	1	490
110	C.GM2E 280 M 4c	1485	195,0	707,4	0,86	94,5	94,5	93,8	7,4	2,5	2,9	1,0	3,0	2,1	750

C.GMEL(L): IE1 efficiency class
C.GM2E(L): IE2 efficiency class

3 Phase, 400 V, 50 Hz, IE3



Duty Type
S1 (Continuous Operation)



Protection Class
IP 55



Insulation Class
F (155°C)



Temperature Rise
B (80 K)



Rated Power	Type	At Rated Power							At Starting				Breakdown Torque Ratio	Moment of Inertia	Approx Weight
		Speed	Current	Torque	Power Coefficient	Efficiency η			Current Ratio		Torque Ratio				
kW		RPM	A	Nm	Cos ϕ	4/4	3/4	1/2	Direct	Y/ Δ	Direct	Y/ Δ			
Aluminum Frame / 2 poles - 3000 RPM															
1,5	C.AGM3EL 80 H 2c	2875	3,1	5	0,83	84,2	84,1	82,8	6,2	-	2,9	-	3,4	0,0020	11,4
3	C.AGM3EL 90 H 2c	2890	6	9,9	0,83	87,1	87,1	86,2	6,8	-	3,2	-	3,9	0,0020	18,3
4	C.AGM3EL 100 L 2b	2900	7,2	13,2	0,91	88,1	88,1	87,8	8	2,7	2,9	1	3,6	0,0031	22,2
5,5	C.AGM3EL 112 M 2b	2915	10	18	0,89	89,2	89,2	88,5	7,8	2,6	2,6	0,9	3,9	0,0045	28,2
9,2	C.AGM3EL 132 M 2c	2930	16,1	30,0	0,92	90,1	90,1	89,5	8,0	2,7	2,2	0,7	3,3	0,026	74
11	C.AGM3EL 132 M 2d	2930	19	35,9	0,92	91,2	91,2	89,8	8,3	2,8	2,6	0,9	3,4	0,030	79
22	C.AGM3EL 160 H 2d	2950	37,5	71,1	0,91	92,7	92,7	91,7	8,2	2,7	2,3	0,8	3,1	0,049	122
30	C.AGM3EL 180 L 2b	2960	50	97	0,93	93,3	93,3	92,4	8,1	2,7	2,95	1	3,6	0,09	158
45	C.AGM3EL 200 H 2c	2960	77,3	145,2	0,89	94	94	93,6	8	2,7	2,9	1	3,1	0,579	264
55	C.AGM3EL 225 M 2b	2975	91,8	176,5	0,92	94,3	94,3	93	8,5	2,8	3	1	3	1,013	281
Aluminum Frame / 4 poles - 1500 RPM															
1,1	C.AGM3EL 80 H 4c	1430	2,75	7,34	0,68	84,1	84,1	83,5	4,8	1,6	2,3	0,75	2,6	0,0018	9
2,2	C.AGM3EL 90 H 4c	1440	5	14,6	0,73	86,7	85,8	84,2	6	-	2,95	-	3,3	0,004	18,1
9,2	C.AGM3EL 132 M 4c	1460	18,3	60,1	0,80	90,4	90,5	90,4	6,6	2,2	2,6	0,9	2,9	0,042	56,3
10	C.AGM3EL 132 H 4d	1470	21,1	65	0,77	91,2	91,2	90,5	7,14	2,38	3,24	1,1	3,61	0,05	75
18,5	C.AGM3EL 160 H 4c	1475	36,1	120	0,8	92,6	92,6	92,2	8,5	2,8	3	1	3,9	0,076	92
30	C.AGM3EL 180 L 4c	1475	54,3	195,2	0,85	93,6	93,6	93,3	7,8	2,5	2,6	1	3,3	0,2	213
37	C.AGM3EL 200 L 4b	1475	65,4	239,6	0,87	93,9	93,9	93,5	8,1	2,7	2,9	0,9	3,3	0,735	228
55	C.AGM3EL 225 M 4c	1480	95,7	354,7	0,88	94,6	94,6	94	9	3	3,9	1,3	3,5	0,71	400
72,5	C.AGM3EL 250 H 4b	1480	138	486,1	0,83	95	94,7	94,5	7,6	2,5	3,5	1,1	2,9	2,1	525
Aluminum Frame / 6 poles - 1000 RPM															
45	C.AGM3EL 250 M 6b	990	84,9	435,5	0,82	93,7	93,7	92,7	7,8	2,6	3,7	1,2	3,1	1,1	382

3 Phase, 400 V, 50 Hz, IE3-IE4



Duty Type
S1 (Continuous Operation)



Protection Class
IP 55



Insulation Class
F (155°C)



Temperature Rise
B (80 K)



Rated Power	Type	At Rated Power							At Starting				Breakdown Torque Ratio	Moment of Inertia	Approx Weight
		Speed	Current	Torque	Power Coefficient	Efficiency η			Current Ratio		Torque Ratio				
kW		RPM	A	Nm	Cos ϕ	4/4	3/4	1/2	Direct	Y/ Δ	Direct	Y/ Δ			

Cast Iron Frame / 2 poles - 3000 RPM

9,2	C.GM3EL 132 M 2c	2930	16,1	30,0	0,92	90,1	90,1	89,5	8,0	2,7	2,2	0,7	3,3	0,026	74
11	C.GM3EL 132 M 2d	2930	19	35,9	0,92	91,2	91,2	89,8	8,3	2,8	2,6	0,9	3,4	0,030	79
22	C.GM3EL 160 H 2d	2950	37,5	71,1	0,91	92,7	92,7	91,7	8,2	2,7	2,3	0,8	3,1	0,050	125
30	C.GM3EL 180 L 2b	2960	50	97	0,93	93,3	93,3	92,4	8,1	2,7	2,95	1	3,6	0,01	161
45	C.GM3EL 200 H 2c	2960	77,3	145,2	0,89	94	94	93,6	8	2,7	2,9	1	3,1	0,581	267
55	C.GM3EL 225 M 2b	2975	91,8	176,5	0,92	94,3	94,3	93	8,5	2,8	3	1	3	0,41	430
75	C.GM3E 250 H 2b	2975	126,5	243,5	0,92	94,7	94,1	94,1	8,1	2,7	2,9	0,9	2,8	1,31	511
110	C.GM3E 280 H 2c	2980	181,3	352,5	0,9	95,2	95,2	94,5	8,2	2,7	3,3	1,1	3,1	0,65	655
110	C.GM4E 280 H 2c	2980	183,8	352,5	0,9	96	95,7	95,3	7,8	2,6	2,6	0,9	2,9	0,68	683

Cast Iron Frame / 4 poles - 1500 RPM

9,2	C.GM3EL 132 M 4c	1460	18,3	60,1	0,80	90,4	90,5	90,4	6,6	2,2	2,6	0,9	2,9	0,042	63
10	C.GM3EL 132 H 4d	1465	21,4	65,2	0,74	91,2	91,2	90,2	7,1	2,4	3,1	1	3,6	0,039	90
18,5	C.GM3EL 160 H 4c	1475	36,1	120	0,8	92,6	92,6	92,2	8,5	2,8	3	1	3,9	0,078	95
30	C.GM3EL 180 L 4c	1475	54,3	195,2	0,85	93,6	93,6	93,3	7,8	2,5	2,6	1	3,3	0,21	215
37	C.GM3EL 200 L 4b	1475	65,4	239,6	0,87	93,9	93,9	93,5	8,1	2,7	2,9	0,9	3,3	0,561	250
55	C.GM3EL 225 M 4c	1480	95,7	354,7	0,88	94,6	94,6	94	9	3	3,9	1,3	3,5	0,72	405
75	C.GM3EL 250 H 4b	1480	138	486,1	0,83	95	94,7	94,5	7,6	2,5	3,5	1,1	2,9	2,1	550
110	C.GM3E 280 H 4c	1485	193,3	707,5	0,86	95,4	95,4	94,4	7,5	2,5	2,9	1	3	1,36	710
110	C.GM4E 280 H 4c	1480	194	708,7	0,85	96,3	96,1	95,9	7,6	2,5	2,8	0,9	3,1	1,36	724

Cast Iron Frame / 6 poles - 1000 RPM

45	C.GM3E 250 M 6b	990	84,9	435,5	0,82	93,7	93,7	92,7	7,8	2,6	3,7	1,2	3,1	1,1	382
----	-----------------	-----	------	-------	------	------	------	------	-----	-----	-----	-----	-----	-----	-----

C.GM3E(L): IE3 efficiency class
C.GM4E(L): IE4 efficiency class



3 PHASE ASYNCHRONOUS MOTORS / SPARE PARTS

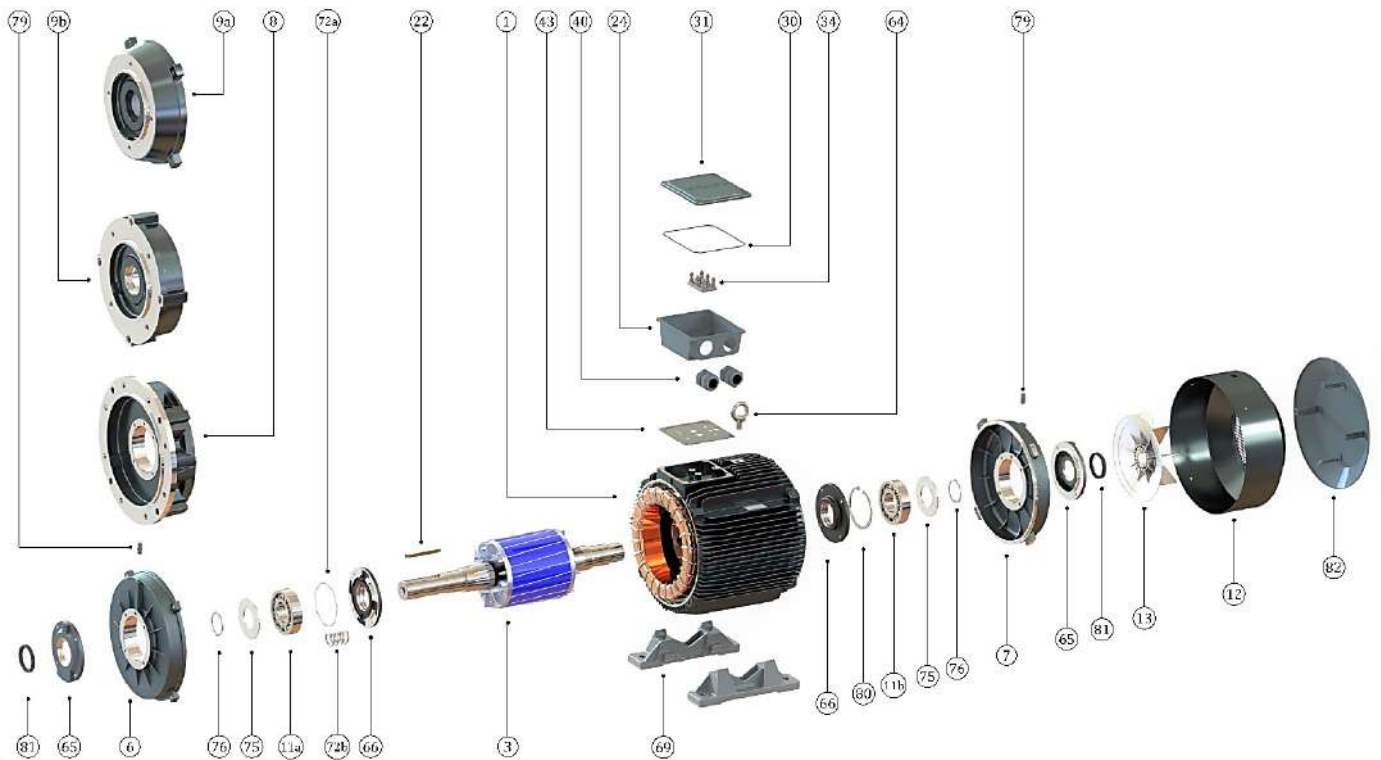

- | | |
|-----|--|
| 1 | Stator with complete windings: Varnished and installed to the body |
| 3 | Complete Rotor: With balanced, shaft, machined (excluding keys), front End-Shields |
| 6 | Drive End Endshield |
| 7 | Non-Drive End Endshield |
| 8 | Flange (Form A - "FF"): B5 |
| 9a | Flange (Form C - "FT"): B14 |
| 9b | Flange (Form C - "FT", Large Type): B14/2 |
| 11a | Drive-End Bearing |
| 11b | Non-Drive End Bearing |
| 12 | Fan End-Shields |
| 13 | Cooling Fan |
| 22 | Shaft End Key |
| 24 | Terminal Box |
| 30 | Seal |
| 31 | Terminal Box End-Shields |
| 34 | Terminal |
| 40 | Cable Entry Gland |
| 43 | Seal (Between Terminal Box and Motor Frame) |
| 64 | Lifting Eye |
| 65 | Bearing Holder Outer End-Shields (For Motors with Lubrication Nipple) |
| 66 | Bearing Holder Inner End-Shields (For Motors with Lubrication Nipple) |
| 69 | Mounting Foot (Our Cast Iron Frame Motors have fixed feet) |
| 72a | Bearing Preload Spring |
| 72b | Coil Spring |
| 75 | Oil Retaining Disc (For Motors with Lubrication Nipple) |
| 76 | Outer Snap Ring (For Motors with Front and Rear Lubrication Nipples, at the front Between 160-280 Frame) |
| 79 | Grease Fitting Spacer |
| 80 | Inner Snap Ring (For Fixing the Rear Bearing in the End-Shields (for 160...280 frame)) |
| 81 | Oil Seal (At the Front and Dust Seal at the Rear as Standard) |
| 82 | Canopy |

3 PHASE ASYNCHRONOUS MOTORS / MOTOR DIMENSIONS

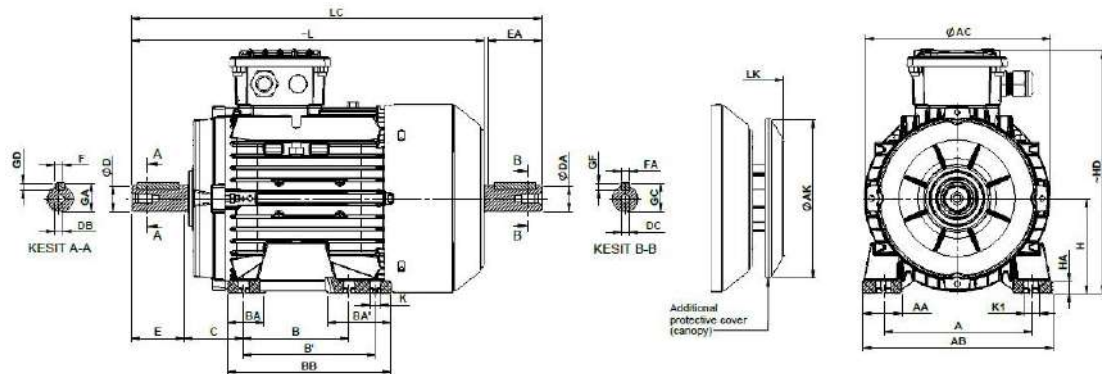

Note: The spindle collar and flange seating surface are in the same plane.

ALUMINUM MOTORS: FOOT MOUNTED MOTOR (IEC 60072-1) - B3, B6, B7, B8, B15, V5, V6

Frame Size	H	HD	HA	A	AA	AB	ACØ	AKØ	KØ	K1	B	B'	BA	BA'	BB	L	LC	LK	C	E EA	DB DC	DØ DAØ	GA GC	FxGD FAXGF
63 M	63	160	10	100	29	125	121	116	7	11	80	-	27	-	103	216	243	245	40	23	M4	11	12,5	4X4
71 M	71	190	10	112	30	140	138	116	7	11	90	-	27	-	108	249	284	278	45	30	M5	14	16	5X5
80 M	80	206	10	125	33	160	156	150	10	14	100	-	35	-	125	279	326	309	50	40	M6	19	21,5	6X6
80 H	80	206	10	125	33	160	156	150	10	14	100	-	35	-	125	296	341	326	50	40	M6	19	21,5	6X6
90 S	90	230	12	140	37	180	176	150	10	15	100	-	35	-	130	310	364	340	56	50	M8	24	27	8x7
90 L	90	230	12	140	37	180	176	150	10	15	100	125	35	60	155	334	389	364	56	50	M8	24	27	8x7
90 H	90	230	12	140	37	180	176	150	10	15	100	125	35	60	155	360	422,5	390	56	50	M8	24	27	8x7
100 L	100	255	13	160	39	200	197	188	12	18	140	-	39	-	175	397	464	442	63	60	M10	28	31	8X7
100 H	100	255	13	160	39	200	197	188	12	18	140	-	39	-	175	432	495	472	63	60	M10	28	31	8X7
112 M	112	265	13	190	52	230	218	188	12	18	140	-	39	-	175	403,5	472	449	70	60	M10	28	31	8X7
112 H	112	265	13	190	52	230	218	188	12	18	140	-	39	-	175	432,5	499	478	70	60	M10	28	31	8X7
132 S	132	332	15	216	51	260	260	230	12	18	140	-	55	-	180	476	567	516	89	80	M12	38	41	10X8
132 M	132	332	15	216	51	260	260	230	12	18	178	-	55	-	218	521	612	561	89	80	M12	38	41	10X8
132 H	132	332	15	216	51	260	260	230	12	-	178	-	55	-	218	561	656	601	89	80	M12	38	41	10X8
160 M	160	401	22	254	63	312	315	290	15	19	210	254	70	-	310	630	746	687	108	110	M16	42	45	12X8
160 L	160	401	22	254	63	312	315	290	15	19	254	-	70	-	304	675	791	732	108	110	M16	42	45	12X8
160 H	160	401	22	254	63	312	315	290	15	15	254	-	70	-	304	731	846	788	108	110	M16	42	45	12X8
180 M	180	445	24	279	74	354	354	290	15	19	241	279	75	-	329	686	802	743	121	110	M16	48	51,5	14X9
180 L	180	445	24	279	74	354	354	290	15	19	279	-	75	-	329	723	839	780	121	110	M16	48	51,5	14X9
200 L	200	500	26	318	81	398	394	370	19	24	305	-	80	-	365	819	937	875	133	110	M20	55	59	16X10
200 H	200	500	26	318	81	398	394	370	19	24	305	-	80	-	365	859	977	915	133	110	M20	55	59	16X10
225 S (2 pole)	226	538	30	356	82	438	440	370	19	24	286	311	98	123	365	758	880	814	149	110	M20	55	59	16x10
225 S (4-6-8 pole)	225	538	30	356	82	438	440	370	19	24	286	311	98	123	365	788	940	844	149	140	M20	60	64	18x11
225 M (2 pole)	225	538	30	356	81	438	440	370	19	24	286	311	98	123	365	851	973	907	149	110	M20	55	59	16x10
225 M (4-6-8 pole)	225	538	30	356	81	438	440	370	19	24	286	311	98	123	365	881	1033	937	149	140	M20	60	64	18x11
250 M (2 pole)	250	566	35	406	92	480	483	440	24	29	349	-	77,5	98	410	892	1044	948	168	140	M20	60	64	18X11
250 M (4-6-8 pole)	250	566	35	406	92	480	483	440	24	29	349	-	77,5	98	410	892	1044	948	168	140	M20	65	69	18X11
250 H (2 pole)	250	566	35	406	92	480	483	440	24	29	349	-	77,5	98	410	981	1134	1037	168	140	M20	60	64	18X11
250 H (4-6-8 pole)	250	566	35	406	92	480	483	440	24	29	349	-	77,5	98	410	981	1134	1037	168	140	M20	65	69	18X11

*Please contact us for IE4 efficiency class motors with dual shaft outputs (LC).

All dimensions are in mm

3 PHASE ASYNCHRONOUS MOTORS / MOTOR DIMENSIONS

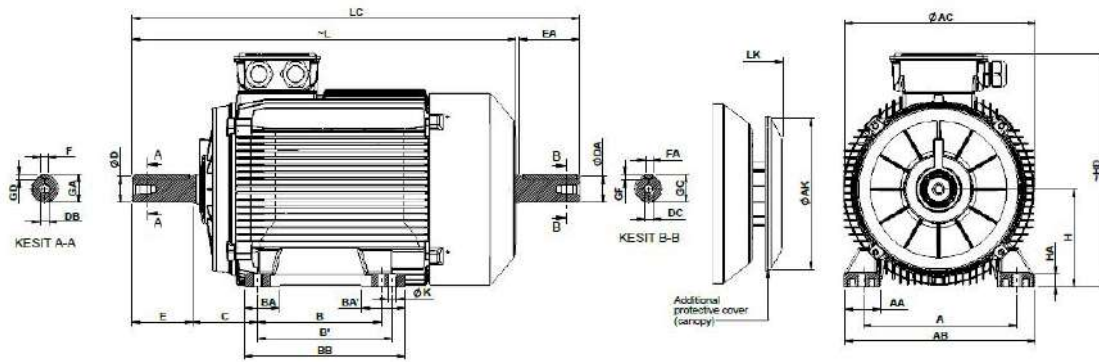

Note: The spindle collar and flange seating surface are in the same plane.

CAST IRON MOTORS: FOOT MOUNTED MOTOR (IEC 60072-1) - B3, B6, B7, B8, B15, V5, V6

Frame Size	H	HD	HA	A	AA	AB	ACØ	AKØ	KØ	K1	B	B'	BA	BA'	BB	L	LC	LK	C	E	EA	DB	DC	DØ	DAØ	GA	GC	FxGD	FAXGF
132 S	132	347	15	216	51	260	260	230	12	-	140	-	50	-	180	476	567	516	89	80	M12	38	41	10X8					
132 M	132	347	15	216	51	260	260	230	12	-	178	-	50	-	218	521	612	561	89	80	M12	38	41	10X8					
132 H	132	347	15	216	51	260	260	230	12	-	178	-	50	-	218	563	656	610	89	80	M12	38	41	10X8					
160 M	160	401	22	254	63	312	315	290	15	-	210	254	75	-	305	630	746	687	108	110	M16	42	45	12X8					
160 L	160	401	22	254	63	312	315	290	15	-	254	-	70	-	304	675	791	732	108	110	M16	42	45	12X8					
160 H	160	401	22	254	63	312	315	290	15	-	254	-	70	-	304	731	846	788	108	110	M16	42	45	12X8					
180 M	180	445	24	279	74	354	354	290	15	-	241	-	60	-	291	686	802	743	121	110	M16	48	51,5	14X9					
180 L	180	445	24	279	74	354	354	290	15	-	279	-	70	-	329	723	839	780	121	110	M16	48	51,5	14X9					
200 L	200	500	26	318	81	398	394	370	19	-	305	-	72	-	355	819	937	875	133	110	M20	55	59	16X10					
200 H	200	500	26	318	81	398	394	370	19	-	305	-	80	-	365	859	977	915	133	110	M20	55	59	16X10					
225 S (2 pole)	225	538	30	356	82	438	440	370	19	-	286	311	80	100	365	762	880	818	149	110	M20	55	59	16X10					
225 S (4-6-8 pole)	225	538	30	356	82	438	440	370	19	-	286	311	80	100	365	792	940	848	149	140	M20	60	64	18x11					
225 M (2 pole)	225	538	30	356	82	438	440	370	19	-	286	311	80	100	371	855	973	911	149	110	M20	55	59	16x10					
225 M (4-6-8 pole)	225	538	30	356	82	438	440	370	19	-	286	311	80	100	371	885	1033	941	149	140	M20	60	64	18x11					
250 M (2 pole)	250	583	35	406	80	480	483	440	24	-	349	-	75	-	410	897	-	953	168	140	M20	60	64	18X11					
250 M (4-6-8 pole)	250	583	35	406	80	480	483	440	24	-	349	-	75	-	410	897	1045	953	168	140	M20	65	69	18X11					
250 H (2 pole)	250	583	35	406	80	480	483	440	24	-	349	-	75	-	410	985	1134	1041	168	140	M20	60	64	18X11					
250 H (4-6-8 pole)	250	583	35	406	80	480	483	440	24	-	349	-	75	-	410	985	1133	1041	168	140	M20	65	69	18X11					
280 S (2 pole)	280	638	40	457	120	550	547	440	24	-	368	419	85	128	474	963	1106	1019	190	140	M20	65	69	18X11					
280 S (4-6-8 pole)	280	638	40	457	120	550	547	440	24	-	368	419	85	128	474	963	1106	1019	190	140	M20	75	79,5	20X12					
280 M (2 pole)	280	638	40	457	120	550	547	440	24	-	368	419	85	128	474	963	1106	1019	190	140	M20	65	69	18X11					
280 M (4-6-8 pole)	280	638	40	457	120	550	547	440	24	-	368	419	85	128	474	963	1106	1019	190	140	M20	75	79,5	20X12					
280 H (2 pole)	280	638	40	457	120	550	547	440	24	-	368	419	85	128	474	1042	-	1098	190	140	M20	65	69	18X11					
280 H (4-6-8 pole)	280	638	40	457	120	550	547	440	24	-	368	419	85	128	474	1010	-	1066	190	140	M20	75	79,5	20X12					
315 S (2 pole)	315	856	50	508	125	620	614	571	28	-	406	457	115	203	550	1120	1270	1197	216	170	M20	65	69	18X11					
315 S (4-6-8 pole)	315	856	50	508	125	620	614	571	28	-	406	457	115	203	550	1150	1330	1227	216	170	M20	85	90	22X14					
315 M (2 pole)	315	856	50	508	125	620	614	571	28	-	406	457	115	203	550	1120	1270	1197	216	170	M20	65	69	18X11					
315 M (4-6-8 pole)	315	856	50	508	125	620	617	571	28	-	406	457	115	203	550	1150	1330	1227	216	170	M20	85	90	22X14					
315 L (2 pole)	315	856	50	508	125	620	617	571	28	-	508	-	125	-	600	1190	1340	1267	216	140	M20	65	69	18X11					
315 L (4-6-8 pole)	315	856	50	508	125	620	617	571	28	-	508	-	125	-	600	1220	1400	1297	216	170	M20	85	90	22X14					
315 H (2 pole)	315	865	50	508	125	620	617	571	28	-	508	-	150	-	600	1300	1450	1377	216	140	M20	65	69	18X11					
315 H (4-6-8 pole)	315	865	50	508	125	620	617	571	28	-	508	-	150	-	600	1330	1510	1407	216	170	M20	85	90	22X14					
355 M (2 pole)	355	990	50	610	150	740	735	571	28	-	560	-	162	-	685	1349	1517	1426	254	170	M20	80	85	22x14					
355 M (4-6-8 pole)	355	990	50	610	150	740	735	570	28	-	560	-	162	-	685	1385	1597	1462	254	210	M24	100	106	28X16					
355 L (2 pole)	355	990	50	610	150	740	735	571	28	-	630	-	140	-	750	1480	1647	1557	254	170	M20	80	85	22x14					
355 L (4-6-8 pole)	355	990	50	610	150	740	735	571	28	-	630	-	140	-	750	1515	1727	1592	254	210	M24	100	106	28X16					
400 L (2 pole)	400	1100	50	686	165	860	853	704	35	-	800	-	173	-	934	1665	1840	1742	280	170	M20	80	85	22X14					
400 L (4-6-8 pole)	400	1100	50	686	165	860	853	704	35	-	800	-	173	-	934	1705	1920	1782	280	210	M24	110	116	28X16					
450 L (4-6-8 pole)	450	1200	62	800	180	975	960	704	45	-	900	-	200	-	1050	1808	2028	1885	280	210	M24	120	127	32X18					
450 H (4-6-8 pole)	450	1210	62	800	180	975	960	704	45	-	1250	-	300	-	1450	2310	2528	2385	280	210	M24	120	127	32X18					

*Please contact us for IE4 efficiency class motors with dual shaft outputs (LC).

*B6, B7, B8, B8, B15, V5 and V6 mounting types can be applied up to 315 M size.

*Upon request, shaft diameters for 315 frame size 4,6 and 8 pole motors can be produced in the following dimensions:

*Ø80 mm x 170 mm

*Ø90 mm x 170 mm

All dimensions are in mm

3 PHASE ASYNCHRONOUS MOTORS / MOTOR DIMENSIONS

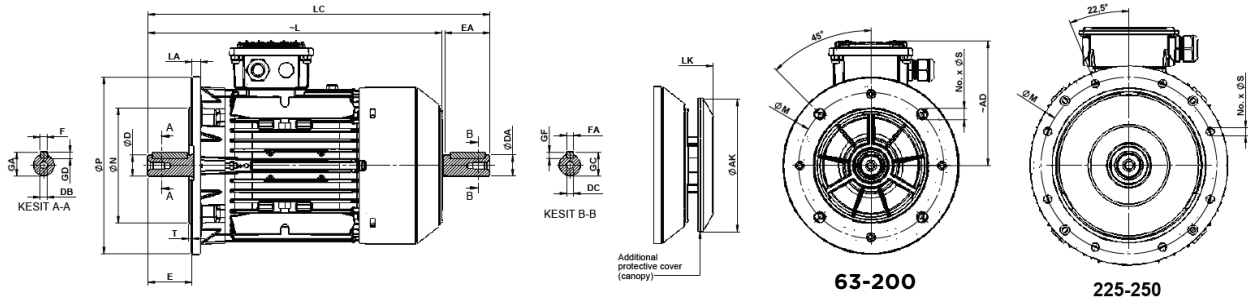

Note: The spindle collar and flange seating surface are in the same plane.

ALUMINUM MOTORS: FLANGED MOTOR (FORM "A" - IEC 60072-1) - B5, V1, V3

Frame Size	Flange No	MØ	NØ	PØ	Fixing Hole		T	LA	AD	AKØ	L	LC	LK	E EA	DB DC	DØ DAØ	GA GC	FxGD FAXGF
					No.	SØ												
63 M	FF 115	115	95	140	4	10	3	10	97	116	216	243	245	23	M4	11	12,5	4X4
71 M	FF 130	130	110	160	4	10	3,5	10	119	116	249	284	278	30	M5	14	16	5X5
80 M	FF 165	165	130	200	4	12	3,5	12	126	151	279	326	309	40	M6	19	21,5	6X6
80 H	FF 165	165	130	200	4	12	3,5	12	126	151	296	341	326	40	M6	19	21,5	6X6
90 S	FF 165	165	130	200	4	12	3,5	12	140	151	310	364	340	50	M8	24	27	8x7
90 L	FF 165	165	130	200	4	12	3,5	12	140	150	334	389	364	50	M8	24	27	8x7
90 H	FF 165	165	130	200	4	12	3,5	12	141	150	360	422,5	390	50	M8	24	27	8x7
100 L	FF 215	215	180	250	4	14,5	4	15	155	188	397	464	437	60	M10	28	31	8X7
100 H	FF 215	215	180	250	4	14,5	4	15	155	188	432	495	472	60	M10	28	31	8X7
112 M	FF 215	215	180	250	4	14,5	4	15	160	188	404	472	449	60	M10	28	31	8X7
112 H	FF 215	215	180	250	4	14,5	4	15	160	188	433	499	478	60	M10	28	31	8X7
132 S	FF 265	265	230	300	4	14,5	4	18	200	230	521	612	561	80	M12	38	41	10X8
132 M	FF 265	265	230	300	4	14,5	4	18	200	230	521	612	561	80	M12	38	41	10X8
132 H	FF 265	265	230	300	4	14,5	4	20	200	230	521	612	561	80	M12	38	41	10X8
160 M	FF 300	300	250	350	4	18,5	5	18	242	290	630	746	687	110	M16	42	45	12X8
160 L	FF 300	300	250	350	4	18,5	5	18	242	290	675	791	732	110	M16	42	45	12X8
160 H	FF 300	300	250	350	4	18,5	5	18	242	290	731	846	788	110	M16	42	45	12X8
180 M	FF 300	300	250	350	4	18,5	5	18	265	290	686	802	743	110	M16	48	51,5	14x9
180 L	FF 300	300	250	350	4	18,5	5	18	265	290	723	839	780	110	M16	48	51,5	14x9
200 L	FF 350	350	300	400	4	18,5	5	20	300	370	819	937	875	110	M20	55	59	16X10
200 H	FF 350	350	300	400	4	18,5	5	20	300	370	859	977	915	110	M20	55	59	16X10
225 S (2 pole)	FF400	400	350	450	8	18,5	5	18	313	370	758	880	814	110	M20	55	59	16X10
225 S (4-6-8 pole)	FF400	400	350	450	8	18,5	5	18	313	370	788	940	844	140	M20	60	64	18x11
225 M (2 pole)	FF400	400	350	450	8	18,5	5	18	313	370	851	973	907	110	M20	55	59	16x10
225 M (4-6-8 pole)	FF400	400	350	450	8	18,5	5	18	313	370	881	1033	937	140	M20	60	64	18x11
250 M (2 pole)	FF 500	500	450	550	8	18,5	5	22	316	440	892	1044	948	140	M20	60	64	18X11
250 M (4-6-8 pole)	FF 500	500	450	550	8	18,5	5	22	316	440	891	1044	948	140	M20	65	69	18X11
250 H (2 pole)	FF 500	500	450	550	8	18,5	5	22	316	440	981	1134	1037	140	M20	60	64	18X11
250 H (4-6-8 pole)	FF 500	500	450	550	8	18,5	5	22	316	440	981	1134	1037	140	M20	65	69	18X11

*Please contact us for IE4 efficiency class motors with dual shaft outputs (LC).

All dimensions are in mm

3 PHASE ASYNCHRONOUS MOTORS / MOTOR DIMENSIONS

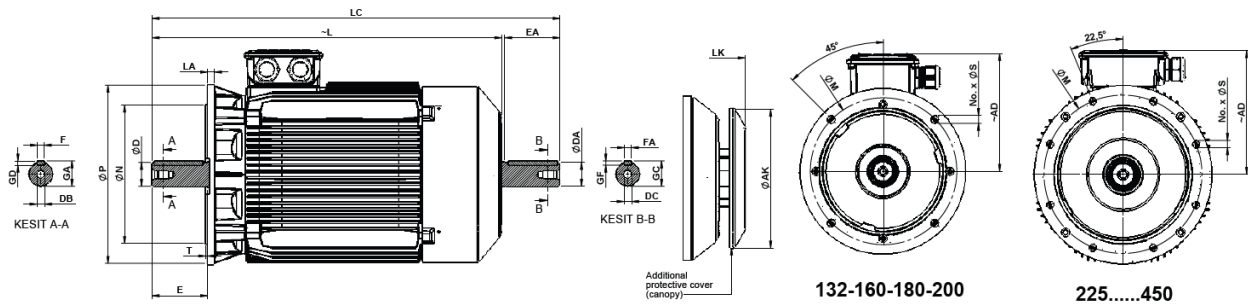

Note: The spindle collar and flange seating surface are in the same plane.

CAST IRON MOTORS: FLANGED MOTOR (FORM "A" - IEC 60072-1) - B5, V1, V3

Frame Size	Flange No	MØ	NØ	PØ	Fixing Hole		T	LA	AD	AKØ	L	LC	LK	E EA	DB DC	DØ DAØ	GA GC	FxGD FAXGF
					No.	SØ												
132 S	FF 265	265	230	300	4	14,5	4	18	200	230	521	612	561	80	M12	38	41	10X8
132 M	FF 265	265	230	300	4	14,5	4	18	200	230	521	612	561	80	M12	38	41	10X8
132 H	FF 265	265	230	300	4	14,5	4	20	200	230	563	656	610	80	M12	38	41	10X8
160 M	FF 300	300	250	350	4	18,5	5	18	242	290	630	746	687	110	M16	42	45	12X8
160 L	FF 300	300	250	350	4	18,5	5	18	242	290	675	791	732	110	M16	42	45	12X8
160 H	FF 300	300	250	350	4	18,5	5	18	242	290	731	846	788	110	M16	42	45	12X8
180 M	FF 300	300	250	350	4	18,5	5	18	265	290	686	802	743	110	M16	48	51,5	14x9
180 L	FF 300	300	250	350	4	18,5	5	18	265	290	723	839	780	110	M16	48	51,5	14x9
200 L	FF 350	350	300	400	4	18,5	5	20	300	370	819	937	875	110	M20	55	59	16X10
200 H	FF 350	350	300	400	4	18,5	5	20	300	370	859	977	915	110	M20	55	59	16X10
225 S (2 pole)	FF400	400	350	450	8	18,5	5	18	313	370	762	880	818	110	M20	55	59	16X10
225 S (4-6-8 pole)	FF400	400	350	450	8	18,5	5	18	313	370	792	940	848	140	M20	60	64	18x11
225 M (2 pole)	FF400	400	350	450	8	18,5	5	18	313	370	855	973	911	110	M20	55	59	16x10
225 M (4-6-8 pole)	FF400	400	350	450	8	18,5	5	18	313	370	885	1033	941	140	M20	60	64	18x11
250 M (2 pole)	FF 500	500	450	550	8	18,5	5	24	335	440	897	1044	953	140	M20	60	64	18X11
250 M (4-6-8 pole)	FF 500	500	450	550	8	18,5	5	24	335	440	897	1044	953	140	M20	65	69	18X11
250 H (2 pole)	FF 500	500	450	550	8	18,5	5	24	335	440	987	1134	1043	140	M20	60	64	18X11
250 H (4-6-8 pole)	FF 500	500	450	550	8	18,5	5	24	335	440	985	1133	1041	140	M20	65	69	18X11
280 S (2 pole)	FF 500	500	450	550	8	18,5	5	24	358	440	963	1106	1019	140	M20	65	69	18X11
280 S (4-6-8 pole)	FF 500	500	450	550	8	18,5	5	24	358	440	963	1106	1019	140	M20	75	79,5	20X12
280 M (2 pole)	FF 500	500	450	550	8	18,5	5	24	358	440	963	1106	1019	140	M20	65	69	18X11
280 M (4-6-8 pole)	FF 500	500	450	550	8	18,5	5	24	358	440	963	1106	1019	140	M20	75	79,5	20X12
280 H (2 pole)	FF 500	500	450	550	8	18,5	5	24	358	440	1042	1188	1098	140	M20	65	69	18X11
280 H (4-6-8 pole)	FF 500	500	450	550	8	18,5	5	24	358	440	1010	1153	1066	140	M20	75	79,5	20X12
315 S (2 pole)	FF 600	600	550	660	8	24	6	22	541	570	1120	1270	1197	140	M20	65	69	18X11
315 S (4-6-8 pole)	FF 600	600	550	660	8	24	6	22	541	570	1150	1330	1227	170	M20	85	90	22X14
315 M (2 pole)	FF 600	600	550	660	8	24	6	24	541	571	1120	1270	1197	140	M20	65	69	18X11
315 M (4-6-8 pole)	FF 600	600	550	660	8	24	6	22	541	570	1150	1330	1227	170	M20	85	90	22X14
315 L (2 pole)	FF 600	600	550	660	8	24	6	22	541	570	1190	1340	1267	140	M20	65	69	18X11
315 L (4-6-8 pole)	FF 600	600	550	660	8	24	6	22	541	570	1220	1400	1297	170	M20	85	90	22X14
315 H (2 pole)	FF 600	600	550	660	8	24	6	24	540	571	1300	1450	1377	140	M20	65	69	18X11
315 H (4-6-8 pole)	FF 600	600	550	660	8	24	6	22	541	570	1330	1510	1407	170	M20	85	90	22X14
355 M (2 pole)	FF 740	740	680	800	8	24	6	32	635	571	1349	1517	1426	170	M20	80	85	22x14
355 M (4-6-8 pole)	FF 740	740	680	800	8	24	6	32	635	571	1385	1597	1462	210	M24	100	106	28X16
355 L (2 pole)	FF 740	740	680	800	8	24	6	32	635	571	1480	1647	1557	170	M20	80	85	22x14
355 L (4-6-8 pole)	FF 740	740	680	800	8	24	6	32	625	571	1515	1727	1592	210	M24	100	106	28X16
400 L (2 pole)	FF 940	940	880	1000	8	28	6	32	700	704	1665	1840	1742	170	M20	80	85	22X14
400 L (4-6-8 pole)	FF 940	940	880	1000	8	28	6	32	700	704	1705	1920	1782	210	M24	110	116	28X16
450 L (4-6-8 pole)	FF1080	1080	1000	1150	8	28	6	34	750	704	1810	2028	1885	210	M24	120	127	32X18
450 H (4-6-8 pole)	FF1080	1080	1000	1150	8	28	6	34	750	704	2310	2528	2385	210	M24	120	127	32X18

*Please contact us for IE4 efficiency class motors with dual shaft outputs (LC).

*Upon request, shaft diameters for 315 structure size 4,6 and 8 pole motors can be produced in the following dimensions:

*Ø80 mm x 170 mm

*Ø90 mm x 170 mm

All dimensions are in mm

3 PHASE ASYNCHRONOUS MOTORS / MOTOR DIMENSIONS

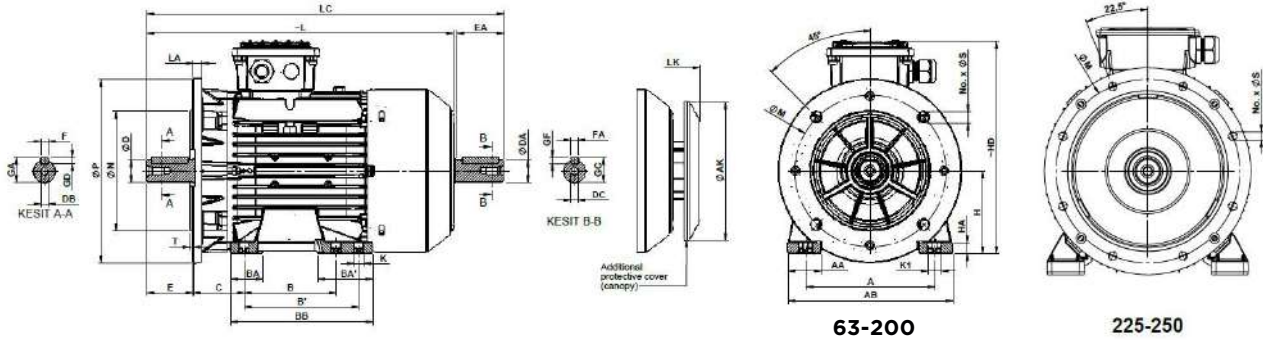

Note: The spindle collar and flange seating surface are in the same plane.

ALUMINUM MOTORS: FOOT MOUNTED AND FLANGED MOTOR FORM "A" - IEC 60072-1) - B35

Frame Size	H	HD	HA	A	AB	AKØ	KØ	K1	B	B'	BA	BA'	BB	Flange No	MØ	NØ	PØ	No	SØ	T	LA	L	LC	LK	C	E EA	DB DC	DØ DAØ	GA GC	FxGD FAXGF
63 M	63	160	10	100	125	116	7	11	80	-	27	-	103	FF 115	115	95	140	4	10	3	10	216	243	245	40	23	M4	11	12,5	4X4
71 M	71	190	10	112	140	116	7	11	90	-	27	-	108	FF 130	130	110	160	4	10	3,5	10	249	284	278	45	30	M5	14	16	5X5
80 M	80	206	10	125	160	150	10	14	100	-	35	-	125	FF 165	165	130	200	4	12	3,5	12	279	325	309	50	40	M6	19	21,5	6X6
80 H	80	206	10	125	160	151	10	14	100	-	35	-	125	FF 165	165	130	200	4	12	3,5	12	296	341	326	50	40	M6	19	21,5	6X6
90 S	90	230	12	140	180	150	10	15	100	-	35	-	130	FF 165	165	130	200	4	12	3,5	12	310	364	340	56	50	M8	24	27	8x7
90 L	90	230	12	140	180	150	10	15	100	125	35	60	155	FF 165	165	130	200	4	12	3,5	12	334	389	364	56	50	M8	24	27	8x7
90 H	90	230	12	140	180	150	10	15	100	125	35	60	155	FF 165	165	130	200	4	12	3,5	12	360	422,5	390	56	50	M8	24	27	8x7
100 L	100	255	13	160	200	188	12	18	140	-	39	-	175	FF 215	215	180	250	4	14,5	4	15	397	464	442	63	60	M10	28	31	8X7
100 H	100	255	13	160	200	188	12	18	140	-	39	-	175	FF 215	215	180	250	4	14,5	4	15	432	495	472	63	60	M10	28	31	8X7
112 M	112	271	13	190	230	188	12	18	140	-	39	-	175	FF 215	215	180	250	4	14,5	4	15	404	472	449	70	60	M10	28	31	8X7
112 H	112	271	13	190	230	188	12	18	140	-	39	-	175	FF 215	215	180	250	4	14,5	4	15	433	499	478	70	60	M10	28	31	8X7
132 S	132	332	15	216	260	230	12	18	140	-	55	-	180	FF 265	265	230	300	4	14,5	4	20	476	567	516	89	80	M12	38	41	10X8
132 M	132	332	15	216	260	230	12	18	178	-	55	-	218	FF 265	265	230	300	4	14,5	4	20	521	612	561	89	80	M12	38	41	10X8
132 H	132	332	15	216	260	230	12	18	178	-	55	-	218	FF 265	265	230	300	4	14,5	4	20	561	656	601	89	80	M12	38	41	10X8
160 M	160	401	22	254	312	290	15	19	210	254	70	-	310	FF 300	300	250	350	4	18,5	5	18	630	746	687	108	110	M16	42	45	12X8
160 L	160	401	22	254	312	290	15	19	254	-	70	-	304	FF 300	300	250	350	4	18,5	5	18	675	791	732	108	110	M16	42	45	12X8
160 H	160	401	22	254	312	290	15	19	254	-	70	-	304	FF 300	300	250	350	4	18,5	5	18	731	846	788	108	110	M16	42	45	12X8
180 M	180	445	24	279	354	290	15	19	241	279	75	-	329	FF 300	300	250	350	4	18,5	5	18	686	802	743	121	110	M16	48	51,5	14X9
180 L	180	445	24	279	354	290	15	19	279	-	75	-	329	FF 300	300	250	350	4	18,5	5	18	723	839	780	121	110	M16	48	51,5	14X9
200 L	200	500	26	318	398	370	19	24	305	-	80	-	365	FF 350	350	300	400	4	18,5	5	20	819	937	743	133	110	M20	55	59	16X10
200 H	200	500	26	318	398	370	19	24	305	-	80	-	365	FF 350	350	300	400	4	18,5	5	20	859	977	915	133	110	M20	55	59	16X10
225 S (2 pole)	225	538	30	356	438	370	19	24	286	311	98	123	365	FF400	400	350	450	8	18,5	5	18	758	880	814	149	110	M20	55	59	16X10
225 S (4-6-8 pole)	225	538	30	356	438	370	19	24	286	311	98	123	365	FF400	400	350	450	8	18,5	5	18	788	940	844	149	140	M20	60	64	18x11
225 M (2 pole)	225	538	30	356	438	370	19	24	286	311	98	123	365	FF400	400	350	450	8	18,5	5	18	851	973	907	149	110	M20	55	59	16x10
225 M (4-6-8 pole)	225	538	30	356	438	370	19	24	286	311	98	123	365	FF400	400	350	450	8	18,5	5	18	881	1033	937	149	140	M20	60	64	18x11
250 M (2 pole)	250	566	35	406	480	440	24	29	349	-	77,5	98	410	FF 500	500	450	550	8	18,5	5	22	892	1044	948	168	140	M20	60	64	18X11
250 M (4-6-8 pole)	250	566	35	406	480	440	24	29	349	-	77,5	98	410	FF 500	500	450	550	8	18,5	5	22	891	1044	948	168	140	M20	65	69	18X11
250 H (2 pole)	250	566	35	406	480	440	24	29	349	-	77,5	98	410	FF 500	500	450	550	8	18,5	5	24	981	1134	1037	168	140	M20	60	64	18X11
250 H (4 pole)	250	566	35	406	480	440	24	29	349	-	77,5	98	410	FF 500	500	450	550	8	18,5	5	24	981	1134	1037	168	140	M20	65	69	18X11

*Please contact us for IE4 efficiency class motors with dual shaft outputs (LC).

All dimensions are in mm

3 PHASE ASYNCHRONOUS MOTORS / MOTOR DIMENSIONS

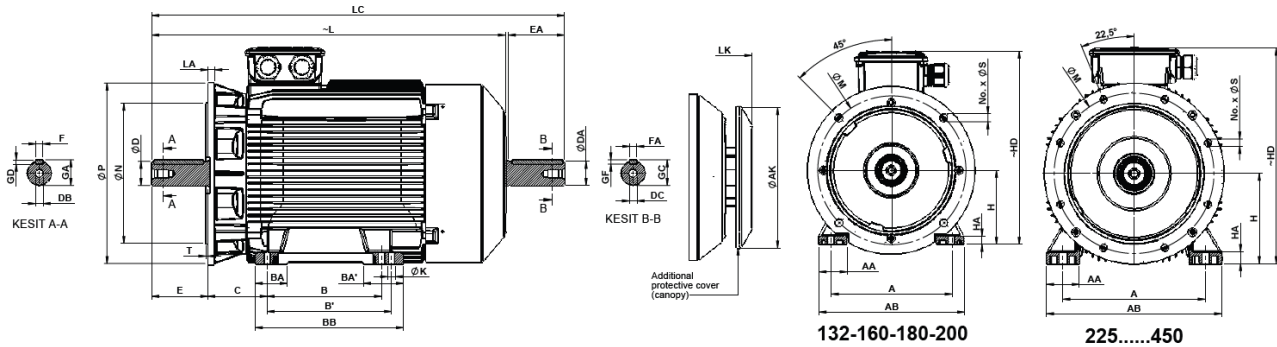

Note: The spindle collar and flange seating surface are in the same plane.

CAST IRON MOTORS: FOOT MOUNTED AND FLANGED MOTOR (FORM "A" - IEC 60072-1) - B35

Frame Size	H	HD	HA	A	AB	AKØ	KØ	K1	B	B'	BA	BA'	BB	Flange No	MØ	NØ	PØ	No	SØ	T	LA	L	LC	LK	C	E EA	DB DC	DØ DAØ	GA GC	FxGD FAXGF
132 S	132	347	15	216	260	230	12	-	140	-	50	-	180	FF 265	265	230	300	4	14,5	4	20	476	567	516	89	80	M12	38	41	10X8
132 M	132	347	15	216	260	230	12	-	178	-	50	-	218	FF 265	265	230	300	4	14,5	4	20	521	612	561	89	80	M12	38	41	10X8
132 H	132	348	15	216	260	230	12	12	178	-	50	-	218	FF 265	265	230	300	4	14,5	4	20	563	656	610	89	80	M12	38	41	10X8
160 M	160	401	22	254	312	290	15	-	210	254	75	-	305	FF 300	300	250	350	4	18,5	5	18	630	746	687	108	110	M16	42	45	12X8
160 L	160	401	22	254	312	290	15	-	254	-	70	-	304	FF 300	300	250	350	4	18,5	5	18	675	791	732	108	110	M16	42	45	12X8
160 H	160	401	22	254	312	290	15	-	254	-	70	-	304	FF 300	300	250	350	4	18,5	5	18	731	846	788	108	110	M16	42	45	12X8
180 M	180	445	24	279	354	290	15	15	241	-	60	-	291	FF 300	300	250	350	4	18,5	5	18	686	802	743	121	110	M16	48	51,5	14X9
180 L	180	445	24	279	354	290	15	15	279	-	60	-	329	FF 300	300	250	350	4	18,5	5	18	723	839	780	121	110	M16	48	51,5	14X9
200 L	200	500	26	318	398	370	19	24	305	-	80	-	365	FF 350	350	300	400	4	18,5	5	20	859	977	915	133	110	M20	55	59	16X10
200 H	200	500	26	318	398	370	19	19	305	-	72	-	365	FF 350	350	300	400	4	18,5	5	20	859	977	915	133	110	M20	55	59	16X10
225 S (2 Kutup)	225	538	30	356	438	370	19	19	286	311	80	100	371	FF400	400	350	450	8	18,5	5	18	762	880	818	149	110	M20	55	59	16X10
225 S (4-6-8 Kutup)	225	538	30	356	438	370	19	19	286	311	80	100	371	FF400	400	350	450	8	18,5	5	18	792	940	848	149	140	M20	60	64	18x11
225 M (2 kutup)	225	538	30	356	438	370	19	19	286	311	80	100	371	FF400	400	350	450	8	18,5	5	18	855	973	911	149	110	M20	55	59	16x10
225 M (4-6-8 kutup)	225	538	30	356	438	370	19	19	286	311	80	100	371	FF400	400	350	450	8	18,5	5	18	885	1033	941	149	140	M20	60	64	18x11
250 M (2 Kutup)	250	583	35	406	480	440	24	-	349	-	75	-	410	FF 500	500	450	550	8	18,5	5	24	897	-	953	168	140	M20	60	64	18X11
250 M (4-6-8 Kutup)	250	583	35	406	480	440	24	-	349	-	75	-	410	FF 500	500	450	550	8	18,5	5	24	897	1045	953	168	140	M20	65	69	18X11
250 H (2 kutup)	250	583	35	406	484	440	24	-	349	-	75	-	410	FF 500	500	450	550	8	18,5	5	24	987	1134	1043	168	140	M20	60	64	18X11
250 H (4-6-8 kutup)	250	583	35	406	484	440	24	-	349	-	75	-	410	FF 500	500	450	550	8	18,5	5	24	985	1133	1041	168	140	M20	65	69	18X11
280 S (2 Kutup)	280	638	40	457	550	440	24	-	368	419	85	128	474	FF 500	500	450	550	8	18,5	5	24	963	1106	1019	190	140	M20	65	69	18X11
280 S (4-6-8 Kutup)	280	638	40	457	550	440	24	-	368	419	85	128	474	FF 500	500	450	550	8	18,5	5	24	963	1106	1019	190	140	M20	75	79,5	20X12
280 M (2 Kutup)	280	638	40	457	550	440	24	-	368	419	85	128	474	FF 500	500	450	550	8	18,5	5	24	963	-	1019	190	140	M20	75	79,5	20X12
280 M (4-6-8 Kutup)	280	638	40	457	550	440	24	-	368	419	85	128	474	FF 500	500	450	550	8	18,5	5	24	963	1106	1019	190	140	M20	75	79,5	20X12
280 H (2 Kutup)	280	638	40	457	550	440	24	-	368	419	85	128	474	FF 500	500	450	550	8	18,5	5	24	1042	-	1098	190	140	M20	75	79,5	20X12
280 H (4-6-8 Kutup)	280	638	40	457	550	440	24	-	368	419	85	128	474	FF 500	500	450	550	8	18,5	5	24	1010	-	1066	190	140	M20	75	79,5	20X12
315 S (2 Kutup)	315	860	50	508	620	571	28	-	406	457	115	203	550	FF 600	600	550	660	8	24	6	24	1120	-	1197	216	140	M20	65	69	18x11
315 S (4-6-8 Kutup)	315	860	50	508	620	571	28	-	406	457	115	203	550	FF 600	600	550	660	8	24	6	24	1150	1330	1227	216	170	M20	85	90	22x14
315 M (2 Kutup)	315	860	50	508	620	571	28	-	406	457	115	203	550	FF 600	600	550	660	8	24	6	24	1120	1270	1197	216	140	M20	65	69	18x11
315 M (4-6-8 Kutup)	315	860	50	508	620	571	28	-	406	457	115	203	550	FF 600	600	550	660	8	24	6	24	1150	1330	1227	216	170	M20	85	90	22x14
315 L (2 Kutup)	315	860	50	508	620	571	28	-	508	-	125	-	600	FF 600	600	550	660	8	24	6	24	1190	1340	1267	216	140	M20	65	69	18x11
315 L (4-6-8 Kutup)	315	860	50	508	620	571	28	-	508	-	125	-	600	FF 600	600	550	660	8	24	6	24	1220	1400	1297	216	170	M20	85	90	22x14
315 H (2 Kutup)	315	865	50	508	620	571	28	-	508	-	125	-	600	FF 600	600	550	660	8	24	6	24	1300	1450	1377	216	140	M20	65	69	18x11
315 H (4-6-8 Kutup)	315	865	50	508	620	571	28	-	508	-	125	-	600	FF 600	600	550	660	8	24	6	24	1330	-	1407	216	170	M20	85	90	22x14
355 M (2 Kutup)	355	990	50	610	740	571	28	-	560	-	162	-	685	FF 740	740	680	800	8	24	6	32	1349	1517	1426	254	170	M20	80	85	22x14
355 M (4-6-8 Kutup)	355	990	50	610	740	571	28	-	560	-	162	-	685	FF 740	740	680	800	8	24	6	32	1385	1605	1462	254	210	M24	100	106	28X16
355 L (2 Kutup)	355	990	50	610	740	571	28	-	630	-	140	-	685	FF 740	740	680	800	8	24	6	32	1480	1647	1557	254	170	M20	80	85	22x14
355 L (4-6-8 Kutup)	355	990	50	610	740	571	28	-	630	-	140	-	750	FF 740	740	680	800	8	24	6	32	1515	1735	1592	254	210	M24	100	106	28X16
400 L (2 Kutup)	400	1100	50	686	860	704	35	-	800	-	173	-	934	FF 940	940	880	1000	8	28	6	32	1665	1840	1742	280	170	M20	80	85	22X14
400 L (4-6-8 Kutup)	400	1100	50	686	860	704	35	-	800	-	173	-	934	FF 940	940	880	1000	8	28	6	32	1705	1920	1782	280	210	M24	110	116	28X16
450 L (4-6-8 Kutup)	450	1200	62	800	180	704	45	-	900	-	200	-	1050	FF1080	1080	1000	1150	8	28	6	34	1810	2028	1885	280	210	M24	120	127	32X18
450 H (4-6-8 Kutup)	450	1210	62	800	180	704	45	-	1250	-	300	-	1450	FF1080	1080	1000	1150	8	28	6	34	2310	2528	2385	280	210	M24	120	127	32X18

*Please contact us for IE4 efficiency class motors with dual shaft outputs (LC).

*Upon request, shaft diameters for 315 structure size 4,6 and 8 pole motors can be produced in the following dimensions:

*Ø80 mm x 170 mm

*Ø90 mm x 170 mm

All dimensions are in mm

3 PHASE ASYNCHRONOUS MOTORS / MOTOR DIMENSIONS

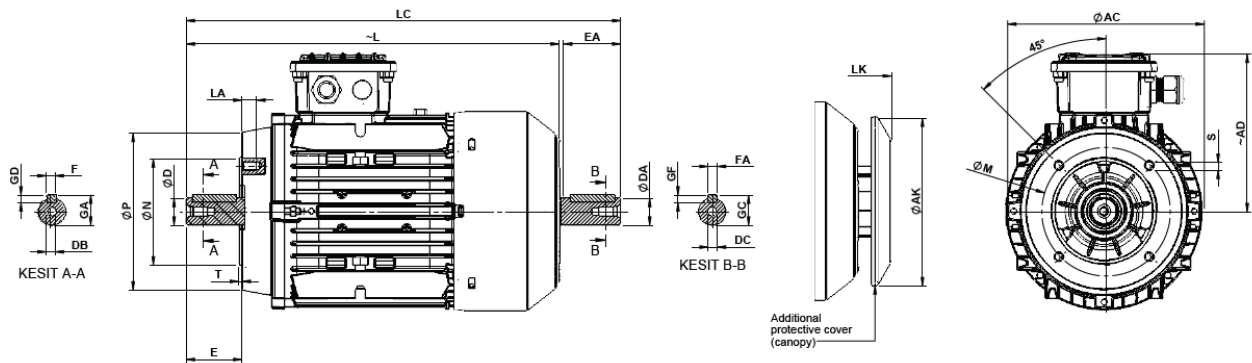

Note: The spindle collar and flange seating surface are in the same plane.

ALUMINUM MOTORS: FLANGED MOTOR (FORM "C" - IEC 60072-1) - B14, V18, V19

Frame Size	Flange No	MØ	NØ	PØ	S	T	LA	ACØ	AKØ	AD	L	LC	LK	E EA	DB DC	DØ DAØ	GA GC	FxGD FAXGF
63 M	FT 75	75	60	90	M5	2,5	10	121	116	97	216	243	245	23	M4	11	12,5	4X4
71 M	FT 85	85	70	105	M6	2,5	12	138	116	119	249	284	278	30	M5	14	16	5x5
80 M	FT100	100	80	120	M6	3	12	156	151	126	279	325	309	40	M6	19	21,5	6x6
80 H	FT100	100	80	120	M6	3	12	156	151	126	296	341	326	40	M6	19	21,5	6x6
90 S	FT 115	115	95	140	M8	3	16	176	150	140	310	364	340	50	M8	24	27	8X7
90 L	FT 115	115	95	140	M8	3	16	176	150	140	334	389	364	50	M8	24	27	8X7
90 H	FT 115	115	95	140	M8	3	16	176	150	140	360	422,5	390	50	M8	24	27	8X7
100 L	FT 130	130	110	160	M8	3,5	16	197	188	155	397	464	442	60	M10	28	31	8X7
100 H	FT 130	130	110	160	M8	3,5	16	197	188	155	432	495	472	60	M10	28	31	8X7
112 M	FF130	130	110	160	M8	3,5	18	218	188	160	404	472	449	60	M10	28	31	8x7
112 H	FF130	130	110	160	M8	3,5	18	218	188	160	433	499	478	60	M10	28	31	8x7
132 S	FT165	165	130	200	M10	3,5	18	260	230	200	476	567	516	80	M12	38	41	10x8
132 M	FT165	165	130	200	M10	3,5	18	260	230	200	521	612	561	80	M12	38	41	10x8
132 H	FT165	165	130	200	M10	3,5	18	260	230	200	561	656	601	80	M12	38	41	10x8
160 M	FT215	215	180	250	M12	4	21	315	290	240	630	746	687	110	M16	42	45	12X8
160 L	FT215	215	180	250	M12	4	21	315	290	240	675	791	732	110	M16	42	45	12X8
160 H	FT215	215	180	250	M12	4	21	315	290	240	731	846	788	110	M16	42	45	12X8

*Please contact us for IE4 efficiency class motors with dual shaft outputs (LC).

All dimensions are in mm

3 PHASE ASYNCHRONOUS MOTORS / MOTOR DIMENSIONS

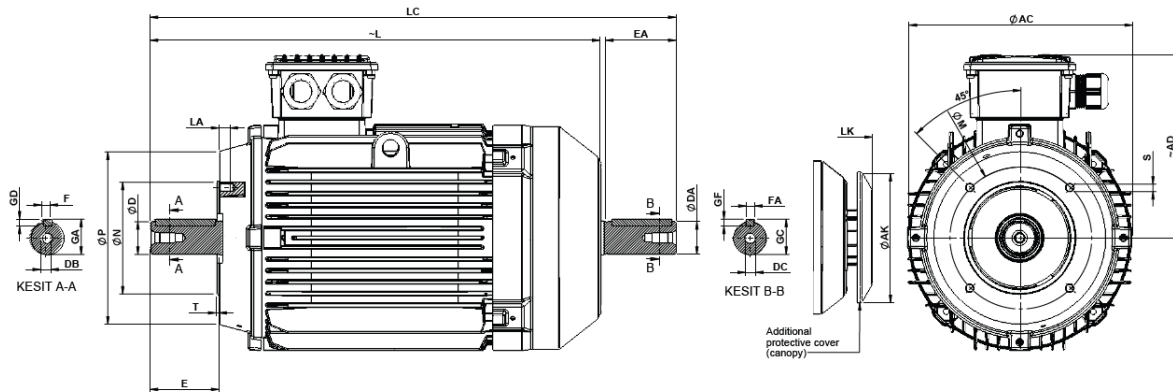

Note: The spindle collar and flange seating surface are in the same plane.

CAST IRON MOTORS: FLANGED MOTOR (FORM "C" - IEC 60072-1) - B14, V18, V19

Frame Size	Flange No	MØ	NØ	PØ	S	T	LA	ACØ	AKØ	AD	L	LC	LK	E EA	DB DC	DØ DAØ	GA GC	FxGD FAXGF
132 S	FT165	165	130	200	M10	3,5	18	260	230	215	476	567	516	80	M12	38	41	10x8
132 M	FT165	165	130	200	M10	3,5	18	260	230	215	521	612	561	80	M12	38	41	10x8
132 H	FT165	165	130	200	M10	3,5	18	260	230	215	563	656	610	80	M12	38	41	10x8
160 M	FT215	215	180	250	M12	4	21	315	290	240	630	746	687	110	M16	42	45	12X8
160 L	FT215	215	180	250	M12	4	21	315	290	240	675	791	732	110	M16	42	45	12X8
160 H	FT215	215	180	250	M12	4	21	315	290	240	731	846	788	110	M16	42	45	12X8

*Please contact us for IE4 efficiency class motors with dual shaft outputs (LC).

All dimensions are in mm

3 PHASE ASYNCHRONOUS MOTORS / MOTOR DIMENSIONS

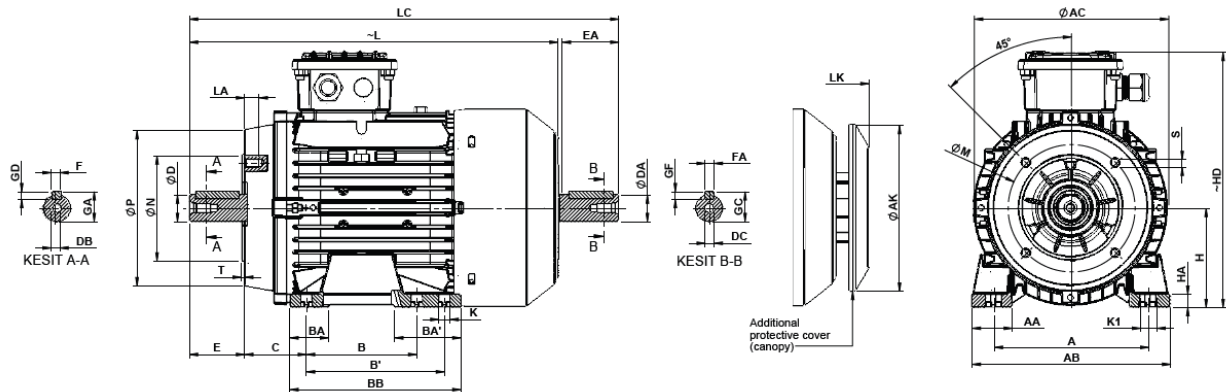

Note: The spindle collar and flange seating surface are in the same plane.

ALUMINUM MOTORS: FOOT MOUNTED AND FLANGED MOTOR (FORM "C" - IEC 60072-1) - B34

Frame Size	H	HD	HA	A	AA	AB	ACØ	AKØ	KØ	K1	B	B'	BA	BA'	BB	Flange No	MØ	NØ	PØ	SØ	T	LA	L	LC	LK	C	E	EA	DB	DC	DØ	DAØ	GA	GC	FxGD	FAXGF
63 M	63	160	10	100	29	125	121	116	7	11	80	-	27	-	103	FT 75	75	60	90	M5	2,5	10	216	243	245	40	23	M4	11	12,5			4X4			
71 M	71	190	10	112	30	140	138	116	7	11	90	-	27	-	108	FT 85	85	70	105	M6	2,5	12	249	284	278	45	30	M5	14	16			5X5			
80 M	80	206	10	125	33	160	156	151	10	14	100	-	35	-	125	FT100	100	80	120	M6	3	12	279	325	309	50	40	M6	19	21,5			6x6			
80 H	80	206	10	125	33	160	156	151	10	14	100	-	35	-	125	FT100	100	80	120	M6	3	12	296	341	326	50	40	M6	19	21,5			6x6			
90 S	90	230	12	140	37	180	176	150	10	15	100	-	35	-	130	FF 115	115	95	140	M8	3	16	310	364	340	56	50	M8	24	27			8X7			
90 L	90	230	12	140	37	180	176	150	10	15	100	125	35	60	155	FT 115	115	95	140	M8	3	16	334	389	364	56	50	M8	24	27			8x7			
90 H	90	230	12	140	37	180	176	150	10	15	100	125	35	60	155	FT 115	115	95	140	M8	3	16	360	422,5	390	56	50	M8	24	27			8X7			
100 L	100	255	13	160	39	200	197	188	12	18	140	-	39	-	175	FT130	130	110	160	M8	3,5	16	397	464	442	63	60	M10	28	31			8x7			
100 H	100	255	13	160	39	200	197	188	12	18	140	-	39	-	175	FT130	130	110	160	M8	3,5	16	432	495	472	63	60	M10	28	31			8x7			
112 M	112	271	13	190	52	230	218	188	12	18	140	-	39	-	175	FT130	130	110	160	M8	3,5	18	404	472	449	70	60	M10	28	31			8x7			
112 H	112	271	13	190	52	230	218	188	12	18	140	-	39	-	175	FT130	130	110	160	M8	3,5	18	433	499	478	70	60	M10	28	31			8x7			
132 S	132	332	15	216	51	260	260	230	12	18	140	-	55	-	180	FT165	165	130	200	M10	3,5	18	476	567	516	89	80	M12	38	41			10x8			
132 M	132	332	15	216	51	260	260	230	12	18	178	-	55	-	218	FT165	165	130	200	M10	3,5	18	521	612	561	89	80	M12	38	41			10x8			
132 H	132	332	15	216	51	260	260	230	12	18	178	-	55	-	218	FT165	165	130	200	M10	3,5	18	561	656	601	89	80	M12	38	41			10x8			
160 M	160	401	22	254	63	312	315	290	15	19	210	254	70	-	310	FT215	215	180	250	M12	4	21	630	746	687	108	110	M16	42	45			12X8			
160 L	160	401	22	254	63	312	315	290	15	19	254	-	70	-	304	FT215	215	180	250	M12	4	21	675	791	732	108	110	M16	42	45			12X8			
160 H	160	401	22	254	63	312	315	290	15	19	254	-	70	-	304	FT215	215	180	250	M12	4	21	731	846	788	108	110	M16	42	45			12X8			

*Please contact us for IE4 efficiency class motors with dual shaft outputs (LC).

All dimensions are in mm

3 PHASE ASYNCHRONOUS MOTORS / MOTOR DIMENSIONS

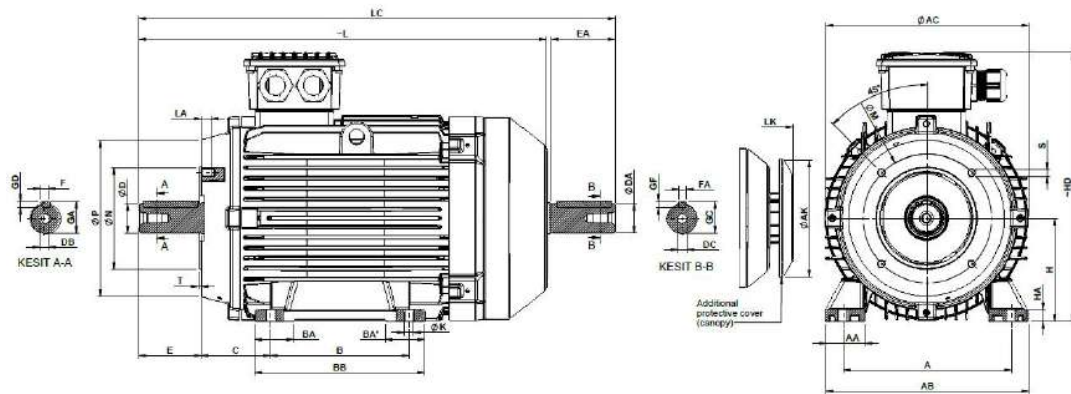

Note: The spindle collar and flange seating surface are in the same plane.

CAST IRON MOTORS: FOOT MOUNTED AND FLANGED MOTOR (FORM "C" - IEC 60072-1) - B34

Frame Size	H	HD	HA	A	AA	AB	AC	AK	K	K1	B	B'	BA	BA'	BB	Flange No	M	N	P	S	T	LA	L	LC	LK	C	E	EA	DB	DC	DA	GA	GC	FxGD	FAXGF
132 S	132	347	15	216	51	260	260	230	12	-	140	-	50	-	180	FT165	165	130	200	M10	3,5	18	476	567	516	89	80	M12	38	41	10x8				
132 M	132	347	15	216	51	260	260	230	12	-	178	-	50	-	218	FT165	165	130	200	M10	3,5	18	521	612	561	89	80	M12	38	41	10x8				
132 H	132	348	15	216	51	260	260	230	12	12	178	-	50	-	218	FT165	165	130	200	M10	3,5	18	563	656	610	89	80	M12	38	41	10x8				
160 M	160	401	22	254	63	312	315	290	15	-	210	254	75	-	305	FT215	215	180	250	M12	4	21	630	746	687	108	110	M16	42	45	12X8				
160 L	160	401	22	254	63	312	315	290	15	-	254	-	70	-	304	FT215	215	180	250	M12	4	21	675	791	732	108	110	M16	42	45	12X8				
160 H	160	401	22	254	63	312	315	290	15	-	254	-	70	-	304	FT215	215	180	250	M12	4	21	731	846	788	108	110	M16	42	45	12X8				

*Please contact us for IE4 efficiency class motors with dual shaft outputs (LC).

All dimensions are in mm

3 PHASE ASYNCHRONOUS MOTORS / MOTOR DIMENSIONS

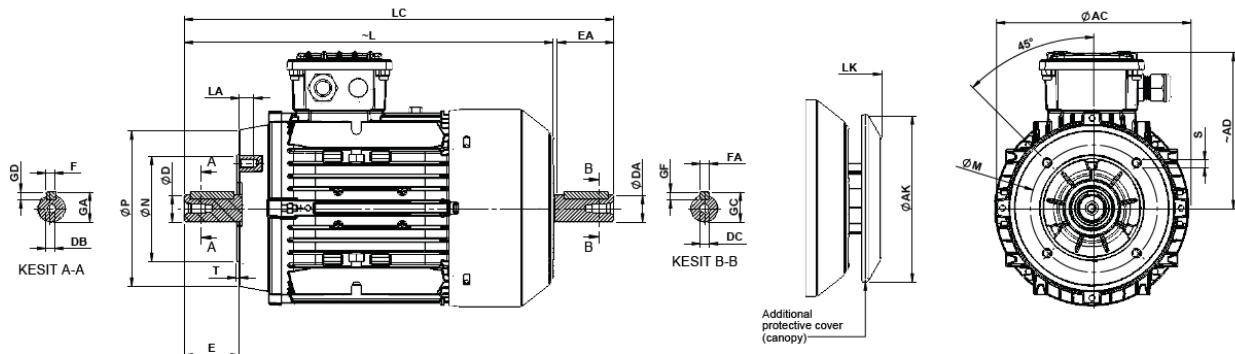

Note: The spindle collar and flange seating surface are in the same plane.

ALUMINUM MOTORS: FLANGED MOTOR (FORM "C" - IEC 60072-1) - B14-2, V18, V19

Frame Size	Flange No	MØ	NØ	PØ	S	T	LA	ACØ	AKØ	AD	L	LC	LK	E EA	DB DC	DØ DAØ	GA GC	FxGD FAXGF
63 M	FT 100	100	80	120	M6	3	12	121	116	97	216	243	245	23	M4	11	12,5	4X4
71 M	FT 115	115	95	140	M8	3	16	138	116	119	249	284	278	30	M5	14	16	5X5
80 M	FT 130	130	110	160	M8	3,5	16	156	151	126	279	326	309	40	M6	19	21,5	6x6
80 H	FT 130	130	110	160	M8	3,5	16	156	151	126	296	341	326	40	M6	19	21,5	6x6
90 S	FT130	130	110	160	M8	3,5	16	176	150	140	310	364	340	50	M8	24	27	8X7
90 L	FT130	130	110	160	M8	3,5	16	176	150	140	334	389	364	50	M8	24	27	8X7
90 H	FT130	130	110	160	M8	3,5	16	176	150	140	360	422,5	390	50	M8	24	27	8X7
100 L	FT 165	165	130	200	M10	3,5	20	197	188	155	397	464	442	60	M10	28	31	8X7
100 H	FT 165	165	130	200	M10	3,5	20	197	188	155	432	495	472	60	M10	28	31	8X7
112 M	FF165	165	130	200	M10	3,5	18	218	188	160	404	472	449	60	M10	28	31	8X7
112 H	FF165	165	130	200	M10	3,5	18	218	188	160	433	499	478	60	M10	28	31	8X7
132 S	FT215	215	180	180	M12	4	20	260	230	200	476	567	516	80	M12	38	41	10x8
132 M	FT215	215	180	180	M12	4	20	260	230	200	521	612	561	80	M12	38	41	10X8
132 H	FT215	215	180	180	M12	4	20	260	230	200	561	656	601	80	M12	38	41	10x8

*Please contact us for IE4 efficiency class motors with dual shaft outputs (LC).

All dimensions are in mm

3 PHASE ASYNCHRONOUS MOTORS / MOTOR DIMENSIONS

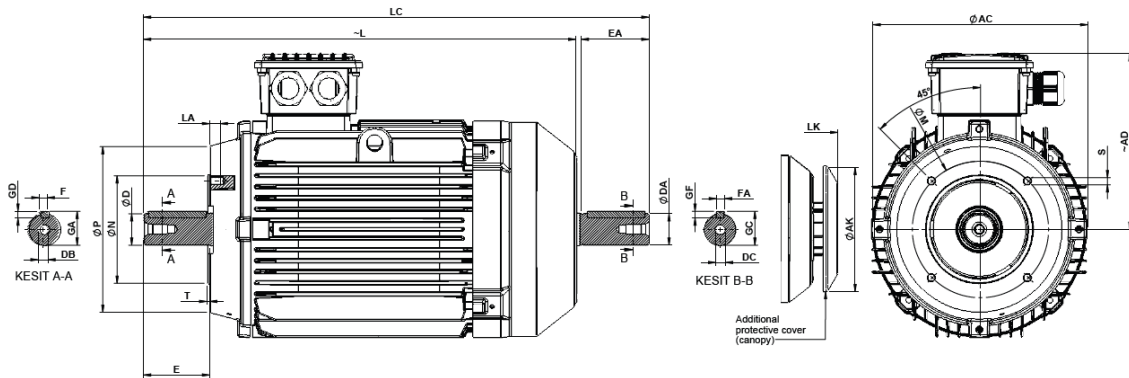

Note: The spindle collar and flange seating surface are in the same plane.

CAST IRON MOTORS: FLANGED MOTOR (FORM "C" - IEC 60072-1) - B14-2, V18, V19

Frame Size	Flange No	MØ	NØ	PØ	S	T	LA	ACØ	AKØ	AD ~	L ~	LC	LK ~	E EA	DB DC	DØ DAØ	GA GC	FxGD FAXGF
132 S	FT215	215	180	180	M12	4	20	260	230	215	476	567	516	80	M12	38	41	10x8
132 M	FT215	215	180	180	M12	4	20	260	230	215	521	612	561	80	M12	38	41	10X8
132 H	FT215	215	180	180	M12	4	20	260	230	215	563	656	610	80	M12	38	41	10x8

*Please contact us for IE4 efficiency class motors with dual shaft outputs (LC).

All dimensions are in mm

3 PHASE ASYNCHRONOUS MOTORS / MOTOR DIMENSIONS

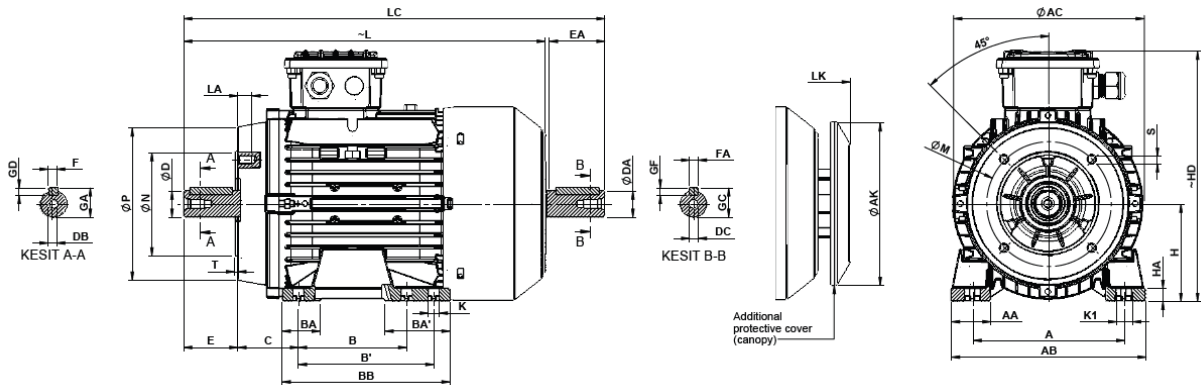

Note: The spindle collar and flange seating surface are in the same plane.

ALUMINUM MOTORS: FOOT MOUNTED AND FLANGED MOTOR (FORM "C" - IEC 60072-1) - B34-2

Frame Size	H	HD	HA	A	AA	AB	AC	AK	K	K1	B	B'	BA	BA'	BB	Flange No	M	N	P	S	T	LA	L	LC	LK	C	E	EA	DC	DA	DA	GA	GC	FxGD	FAXGF
63 M	63	160	10	100	29	125	121	116	7	11	80	-	27	-	103	FT 100	100	80	120	M6	3	12	216	243	245	40	23	M4	11	12,5			4x4		
71 M	71	190	10	112	30	140	138	116	7	11	90	-	27	-	108	FT 115	115	95	140	M8	3	16	249	284	278	45	30	M5	14	16			5x5		
80 M	80	206	10	125	33	160	156	151	10	14	100	-	35	-	125	FT130	130	110	160	M8	3,5	16	279	326	309	50	40	M6	19	21,5			6x6		
80 H	80	206	10	125	33	160	156	151	10	14	100	-	35	-	125	FT130	130	110	160	M8	3,5	16	296	341	326	50	40	M6	19	21,5			6x6		
90 S	90	230	12	140	37	180	176	150	10	15	100	-	35	-	130	FF 130	130	110	160	M8	3,5	16	310	364	340	56	50	M8	24	27			8x7		
90 L	90	230	12	140	37	180	176	150	10	15	100	125	35	60	155	FT 130	130	110	160	M8	3,5	16	334	389	364	56	50	M8	24	27			8x7		
90 H	90	230	12	140	37	180	176	150	10	15	100	125	35	60	155	FT 130	130	110	160	M8	3,5	16	360	422,5	390	56	50	M8	24	27			8x7		
100 L	100	255	13	160	39	200	197	188	12	18	140	-	39	-	175	FT165	165	130	200	M10	3,5	20	397	464	442	63	60	M10	28	31			8x7		
100 H	100	255	13	160	39	200	197	188	12	18	140	-	39	-	175	FT165	165	130	200	M10	3,5	20	432	495	472	63	60	M10	28	31			8x7		
112 M	112	271	13	190	52	230	218	188	12	18	140	-	39	-	175	FT165	165	130	200	M10	3,5	18	404	472	449	70	60	M10	28	31			8x7		
112 H	112	271	13	190	52	230	218	188	12	18	140	-	39	-	175	FT165	165	130	200	M10	3,5	18	433	499	478	70	60	M10	28	31			8x7		
132 S	132	332	15	216	51	260	260	230	12	18	140	-	55	-	180	FT215	215	180	250	M12	4	20	476	567	561	89	80	M12	38	41			10x8		
132 M	132	332	15	216	51	260	260	230	12	18	178	-	55	-	218	FT215	215	180	250	M12	4	20	521	612	561	89	80	M12	38	41			10x8		
132 H	132	332	15	216	51	260	260	230	12	18	178	-	55	-	218	FT215	215	180	250	M12	4	20	561	656	601	89	80	M12	38	41			10x8		

*Please contact us for IE4 efficiency class motors with dual shaft outputs (LC).

3 PHASE ASYNCHRONOUS MOTORS / MOTOR DIMENSIONS

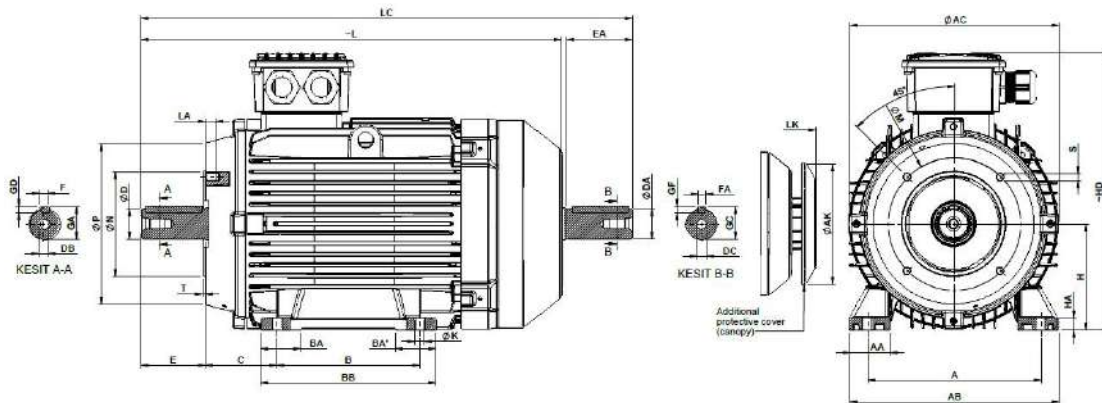

Note: The spindle collar and flange seating surface are in the same plane.

CAST IRON MOTORS: FOOT MOUNTED VE FLANGED MOTOR (FORM "C" - IEC 60072-1) - B34-2

Frame Size	H	HD	HA	A	AA	AB	AC	AK	K	K1	B	B'	BA	BA'	BB	Flange No	MØ	NØ	PØ	SØ	T	LA	L	LC	LK	C	E	EA	DB	DC	DØ	DAØ	GA	GC	FxGD	FAXGF
132 S	132	347	15	216	51	260	260	230	12	-	140	-	50	-	180	FT215	215	180	250	M12	4	20	476	567	516	89	80	M12	38	41	10x8					
132 M	132	347	15	216	51	260	260	230	12	-	178	-	50	-	218	FT215	215	180	250	M12	4	20	521	612	561	89	80	M12	38	41	10x8					
132 H	132	348	15	216	51	260	260	230	12	12	178	-	50	-	218	FT215	215	180	250	M12	4	20	563	656	610	89	80	M12	38	41	10x8					

*Please contact us for IE4 efficiency class motors with dual shaft outputs (LC).

EX-PROOF MOTORS

Special
Series



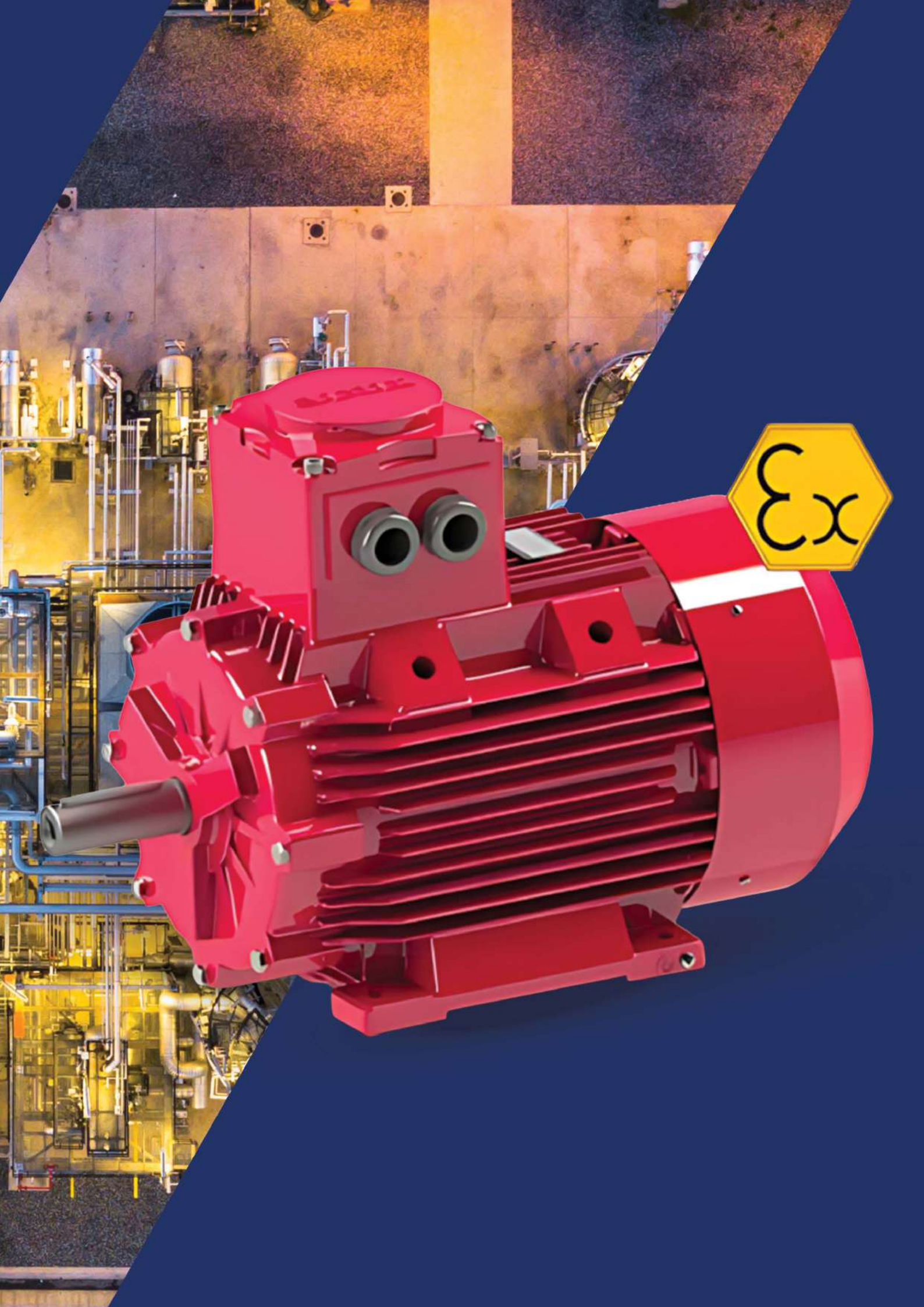

EX-PROOF MOTORS

II 2G Ex db IIC T4 Gb
 II 2D Ex tb IIIC T135°C Db

Ex-Proof Motors Features	
Power Range	0,18-55 kW
Pole	2-4-6-8
Efficiency Class	IE1 - IE2 - IE3
Frame Sizes	71-250
Frame Material	Cast Iron
IP	65
Protection Group	IIC / IIIC
Protection Class	Gas and dust
Insulation class	F(155°C)-H(180°C)
Heat Rise Class	B (80K)
Cooling Mode	TEFC-IC411
Operating Temperature	-20°C / +55°C
Paint	RAL 3009 (Red)
Voltage	220V - 690V / 50 Hz - 60 Hz

Gamak Ex-proof motors provide high safety in flammable and explosive environments with high efficiency and low energy consumption. It is used in industrial sectors such as natural gas plants, shipyards, paint, chemicals, pharmaceuticals, perfumes, and in flammable and explosive gas and dust environments that pose a risk.

What are the features of the Ex-proof motor;

- Possibility of use with drive
- Designed in flameproof class d construction
- Ex-proof motors meet ATEX certification requirements according to the 60079-0, 60079-1 and 60079-31 standards.
- Our installation layouts as in the table.

Type	B3	B5/B35	B14/B34
71	✓	✓	✓
80	✓	✓	✓
90	✓	✓	✓
100	✓	✓	✓
112	✓	✓	✓
132	✓	✓	✓
160	✓	✓	✓
180	✓	✓	x
200	✓	✓	x
225	✓	✓	x
250	✓	x	x



**POWER
 TO
 ENERGIZE
 LIFE**

GAMAK FLAMEPROOF GG SERIES EX-PROOF MOTORS

- 71 M - 80 M - 90 S - 90 L - 100 L - 100 H - 112 M - 132 S - 132 M - 160 M - 160 L - 180 M - 180 L - 200 L - Classified as 225 MS - 250 M according to IEC standards, designed with design criteria specific to the relevant types, electrically designed as 2-4-6 or 8 poles, 3 phase, squirrel cage, asynchronous electric motor group that can be operated with direct supply.
- In motors designed in flameproof class d structure, the frame components are cast iron.
- Designed for operation in flammable and explosive dust and gas environments, the product includes the stator and shaft rotor group that make up the motor, as well as the body, front End-Shields, rear End-Shields, terminal box, terminal box End-Shields and gland-blind plug inlets. The terminal group where the electrical connections that will ensure the operation of the motor are made and the cable connections connected to it remain in the terminal box.
- Ex-Proof motors in the series can be produced in F or H insulation classes upon request. While the copper and insulation varnish forming the stator with class F insulation withstand up to 155 degrees according to the relevant standards, this resistance limit is defined as 180 degrees for class H insulation. Insulation resistance is not related to the maximum surface temperature.
- All Gamak Ex-proof motors are manufactured with thermistor protection elements with a 130 degree opening limit. Thus, if the winding head temperatures in the motor reach the relevant degree, the thermistor will prevent the motor from overheating by preventing the electric current to the motor. Thermistor connections are the responsibility of the user.
- In order to limit the risks that may arise from static electrification in the products, the paint thickness on the protection casing is limited to 200 microns and the rotary plastic impeller raw material is selected from special raw material with a surface resistance below E9 ohm.
- The operating temperature range of the motors in the series is limited to -20 / +55 degrees.
- Painting of the motor by the end user is prohibited.
- Grounding connections are the responsibility of the end user.
- The motors are rated at 230/400 and 400/690V 50 Hz.
- The motors are designed for S1 mode of operation. For different operating values (S2-S3..etc.), maximum surface temperature tests must be performed and verified.
- The motors are designed to be II 2G Ex db IIC T4 Gb for gas environment and II 2D Ex tb T135°C Db for dust environment.
- All technical information about the product, the responsibilities of the end user and the definitions of the quality management system are included in the user manual supplied with the motor. The responsibility for the product will be the responsibility of the end user after commissioning.
- C (if compact motor) GG(1-2-3) Exd (71-80-160...) (S-M-L-MS-H) (2-4-6-8) (a-b-c) is used as coding structure on the motor label.

GG	Gamak Ex-proof motor
1-2-3	Energy efficiency class designation (IE1-IE2-IE3)
Exd	Motor with class D protection structure
71-80-90....	Motor type defined according to IEC regulations
S-M-L-SM-H	Frame length
2-4-6-8	Number of poles
a-b-c	Package size

EX-PROOF MOTORS / SPARE PARTS

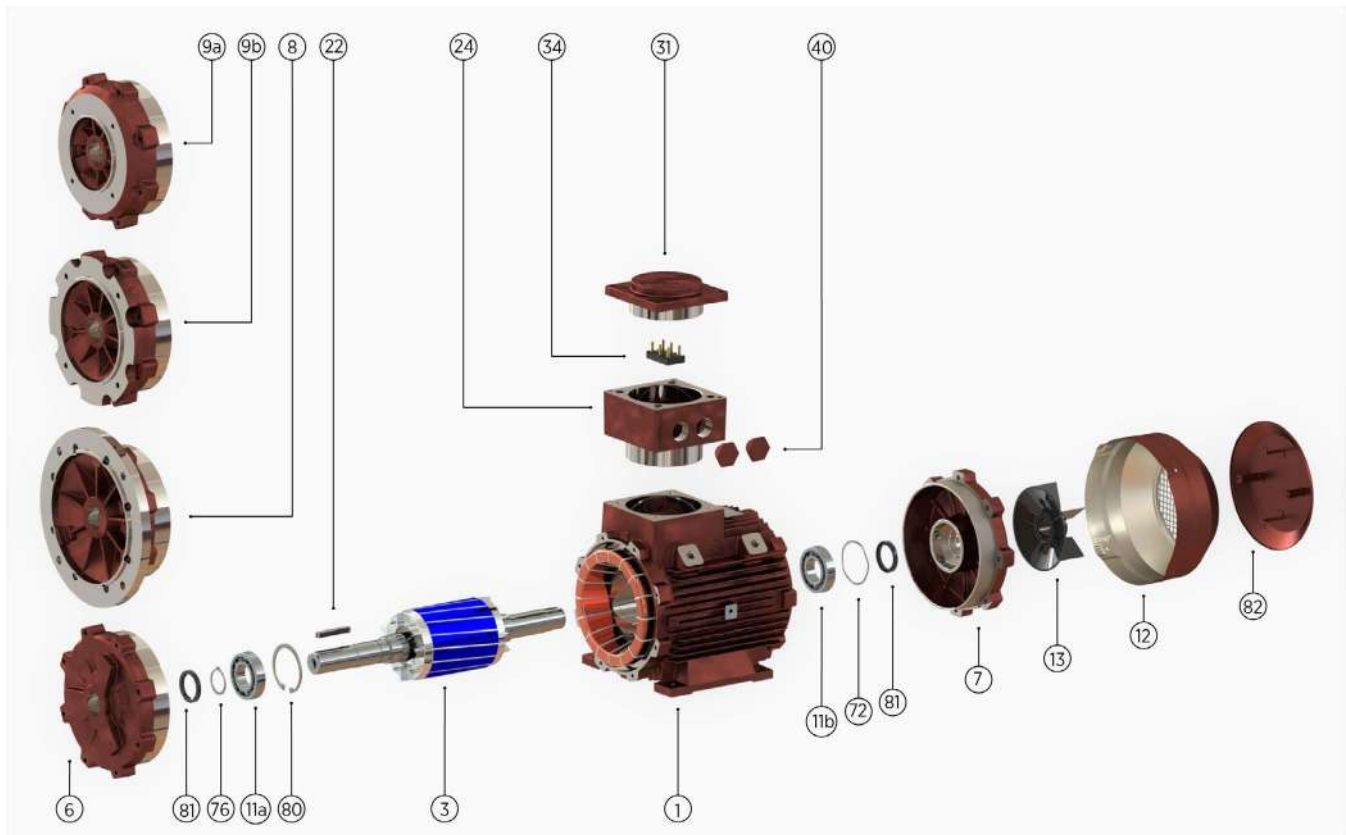

- | | |
|-----|--|
| 1 | Stator with Complete Windings: Varnished and installed to the body |
| 3 | Complete Rotor: With balanced, shaft, machined (excluding keys) |
| 6 | Front End-Shields |
| 7 | Rear End-Shields |
| 8 | Flange (Form A - "FF"): B5 |
| 9a | Flange (Form C - "FT"): B14 |
| 9b | Flange (Form C - "FT", Large Type): B14/2 |
| 11a | Front Bearing |
| 11b | Rear Bearing |
| 12 | Fan Housing Bowl |
| 13 | Cooling Fan |
| 22 | Shaft Key |
| 24 | Terminal Box |
| 31 | Terminal Box End-Shields |
| 34 | Connector |
| 40 | Blind Plug |
| 72 | Bearing Preload Spring |
| 76 | Outer Ring |
| 80 | Inner Ring |
| 81 | Oil Seal |
| 82 | Canopi |



3 Phase, 400 V, 50 Hz, IE1



Duty Type
S1 (Continuous Operation)



Protection Class
IP 65



Insulation Class
F (155°C)



Temperature Rise
B (80 K)



Rated Power	Type	Efficiency Class	At Rated Power							At Starting				Breakdown Torque Ratio	Moment of Inertia	Approx. Weight
			Speed	Current	Torque	Power Coefficient	Efficiency η			Current Ratio		Torque Ratio				
kW			RPM	A	Nm	Cos ϕ	4/4	3/4	1/2	Direct	Y/ Δ	Direct	Y/ Δ			

2 poles - 3000 RPM

0,37	GGIExd 71 M 2a	IE1	2735	0,94	1,3	0,89	63,9	63,9	62,9	3,6	-	1,7	-	2,2	0,00026	16,4
0,55	GGIExd 71 M 2b	IE1	2750	1,3	1,9	0,86	69,0	69	68	3,8	-	1,9	-	2,3	0,00034	17,6
0,75	C.GGIExd 71 M 2c	IE1	2855	1,9	2,6	0,79	72,1	72,1	71,1	4,4	-	2,6	-	3,2	0,00039	18,4
0,75	GGIExd 80 M 2a	IE1	2845	1,7	2,5	0,88	72,1	72,1	71,1	4,5	-	2	-	2,7	0,00053	24,3
1,1	GGIExd 80 M 2b	IE1	2835	2,5	3,7	0,85	75,0	75,0	74,0	4,3	-	1,8	-	2,7	0,00066	25,8
1,5	C.GGIExd 80 M 2c	IE1	2850	3,2	5,0	0,88	77,2	77,2	76,2	5	-	2,2	-	3,1	0,00083	27,8
1,5	GGIExd 90 S 2a	IE1	2865	3,2	5,0	0,88	77,2	77,2	76,2	5,2	-	1,9	-	2,6	0,0011	29,9
2,2	GGIExd 90 L 2b	IE1	2875	4,5	7,3	0,89	79,7	79,7	78,7	6	-	2,2	-	2,8	0,0014	34,1
3	C.GGIExd 90 L 2c	IE1	2845	5,9	10,1	0,90	81,5	81,5	80,5	5,6	-	2,3	-	2,6	0,0016	36,6
3	GGIExd 100 L 2a	IE1	2880	5,8	9,9	0,92	81,5	81,5	80,4	6,0	-	2,5	-	3,0	0,0025	46,4
4	C.GGIExd 100 L 2b	IE1	2880	7,9	13,3	0,88	83,1	83,1	82,0	7,2	2,3	2,8	0,9	3,0	0,0025	46,4
4	GGIExd 112 M 2a	IE1	2880	7,90	13,3	0,88	83,1	83,1	82	7,2	2,3	2,8	0,9	3,5	0,0039	53,6
5,5	C.GGIExd 112 M 2b	IE1	2905	9,90	18,1	0,95	84,7	84,7	84	6,2	2	2	0,6	2,5	0,0045	56,7
5,5	GGIExd 132 S 2a	IE1	2905	9,85	18,1	0,95	84,7	84,7	84	6,5	2,1	2,2	0,7	2,5	0,013	83,9
7,5	GGIExd 132 S 2b	IE1	2910	13,6	24,6	0,93	86	86	85,9	7,2	2,3	2,8	0,9	3,0	0,014	93,9
9,2	C.GGIExd 132 S 2c	IE1	2910	16,5	30,2	0,93	86,9	86,9	86	6,5	2,1	2,1	0,7	2,7	0,02	92
11	C.GGIExd 132 M 2d	IE1	2945	19,4	35,7	0,93	87,6	87,6	86,6	6,5	2,1	2,1	0,7	2,6	0,030	79
11	GGIExd 160 M 2a	IE1	2945	19,3	35,7	0,94	87,6	87,6	86,7	6,6	2,1	2,0	0,6	2,6	0,027	143,1
15	GGIExd 160 M 2b	IE1	2945	26,1	48,6	0,94	88,7	88,7	87,7	7,2	2,3	2,1	0,7	2,8	0,035	153,7
18,5	GGIExd 160 L 2c	IE1	2950	32,3	59,9	0,93	89,3	89,3	82,3	7,7	2,5	2,5	0,8	3,0	0,043	176,1
22	C.GGIExd 160 L 2d	IE1	2950	38	71,2	0,93	89,9	89,9	89	7,1	2,3	2,3	0,7	2,9	0,045	178
22	GGIExd 180 M 2a	IE1	2950	38,3	71,2	0,92	89,9	89,9	89	8,2	2,6	3,0	1,0	3,5	0,066	259,5
30	C.GGIExd 180 L 2b	IE1	2970	52	96,5	0,92	90,7	90,7	89,7	8,3	2,7	2,7	0,9	3	0,25	290
30	GGIExd 200 L 2a	IE1	2970	52	96,5	0,92	90,7	90,7	90	8,3	2,7	2,7	0,9	3,0	0,21	360,7
37	GGIExd 200 L 2b	IE1	2970	65	119	0,90	91,2	91,2	90,5	8,3	2,7	2,7	0,9	3,0	0,23	386,5
45	C.GGIExd 200 L 2c	IE1	2975	77	144,5	0,92	91,7	91,7	91	8,0	2,6	2,7	0,9	2,9	0,22	350
45	GGIExd 225 M 2a	IE1	2975	75	144,5	0,94	91,7	91,7	91	8,0	2,6	2,4	0,8	2,9	0,23	445,3
55	C.GGIExd 225 M 2b	IE1	2980	94	176,3	0,92	92,1	92,1	91,2	7,6	2,5	2,6	0,8	2,7	0,45	455
55	GGIExd 250 M 2a	IE1	2980	94,0	176,3	0,92	92,1	92,1	91,1	7,6	2,5	2,6	0,9	2,7	0,32	517
75	C.GGIExd 250 M 2b	IE1	2970	128	241	0,91	92,7	92,7	92,0	6,8	2,2	2,2	0,7	2,4	0,4	570,9

Efficiency values are calculated by indirect measurement method in accordance with IEC 60034-2-1:2014. Additional losses are determined according to test results at variable load values.

3 Phase, 400 V, 50 Hz, IE1



Duty Type
S1 (Continuous Operation)



Protection Class
IP 65



Insulation Class
F (155°C)



Temperature Rise
B (80 K)



Rated Power kW	Type	Efficiency Class	At Rated Power						At Starting				Breakdown Torque Ratio	Moment of Inertia	Approx. Weight	
			Speed RPM	Current A	Torque Nm	Power Coefficient Cos φ	Efficiency η			Current Ratio		Torque Ratio				
							4/4	3/4	1/2	Direct	Y/Δ	Direct	Y/Δ			

4 poles - 1500 RPM

0,25	GGIExd 71 M 4a	IE1	1415	0,73	1,9	0,80	61,5	61,5	60,5	4,5	-	1,7	-	2,2	0,0004	16,4
0,37	GGIExd 71 M 4b	IE1	1415	1	2,7	0,81	66,0	66,0	65,0	4,1	-	1,8	-	2,3	0,00054	17,6
0,55	C.GGIExd 71 M 4c	IE1	1405	1,5	4,0	0,76	70,0	70,0	69,0	3,8	-	1,7	-	2,1	0,00062	18,4
0,55	GGIExd 80 M 4a	IE1	1420	1,5	3,7	0,76	70,0	70,0	69,0	4	-	1,9	-	2,4	0,00083	24,3
0,75	GGIExd 80 M 4b	IE1	1415	1,9	5,1	0,79	72,1	72,1	71,1	4,3	-	2	-	2,5	0,00110	25,8
1,1	C.GGIExd 80 M 4c	IE1	1415	2,8	7,4	0,76	75,0	75,0	74,0	4,5	-	2,5	-	2,8	0,00134	27,8
1,1	GGIExd 90 S 4a	IE1	1420	2,45	7,4	0,86	75	75	74	4,7	-	2	-	2,4	0,00190	29,3
1,5	GGIExd 90 L 4b	IE1	1400	3,9	10,2	0,72	77,2	77,2	76,2	3,8	-	1,9	-	2,4	0,00240	32,8
2,2	C.GGIExd 90 L 4c	IE1	1425	4,7	14,7	0,85	79,7	79,7	78,7	5,4	-	2,5	-	2,9	0,0029	36,6
2,2	GGIExd 100 L 4a	IE1	1420	4,9	14,8	0,81	79,7	79,7	79,0	5,6	-	2,4	-	2,7	0,0044	50,2
3	GGIExd 100 H 4b	IE1	1435	6,7	20	0,79	81,5	81,5	80,8	6,4	-	2,9	-	3,4	0,005	58,6
4	C.GGIExd 100 H 4c	IE1	1440	8,5	26,5	0,82	83,1	83,1	82	6,6	2,1	2,5	0,8	3,3	0,005	58,6
4	GGIExd 112 M 4a	IE1	1440	8,4	26,5	0,83	83,1	83,1	82,0	6,6	2,1	2,5	0,8	3,3	0,0092	58,7
5,5	C.GGIExd 112 M 4b	IE1	1465	11,3	35,9	0,83	84,7	84,7	84	7	2,3	2,8	0,9	3,5	0,009	58
5,5	GGIExd 132 S 4a	IE1	1465	11,2	35,9	0,81	84,7	84,7	84	7,0	2,3	2,8	0,9	3,5	0,021	92,2
7,5	GGIExd 132 M 4b	IE1	1465	15,4	48,9	0,82	86	86	85,1	7,1	2,3	2,7	0,9	3,4	0,026	79
9,2	C.GGIExd 132 M 4c	IE1	1455	19,3	60,1	0,79	86,9	86,9	86	6,6	2,2	2,6	0,9	3,1	0,042	56,3
11	GGIExd 160 M 4a	IE1	1460	21,6	72,0	0,84	87,6	87,6	86,6	6,8	2,2	2,4	0,8	3,0	0,061	157,3
15	GGIExd 160 L 4b	IE1	1470	29,4	97,4	0,83	88,7	88,7	87,8	7,4	2,4	2,8	0,9	3,2	0,082	181,4
18,5	C.GGIExd 160 L 4c	IE1	1470	35	120,2	0,85	89,3	89,3	82,3	7,7	2,5	3,2	1,0	3,4	0,043	176,1
18,5	GGIExd 180 M 4a	IE1	1470	34,5	120,2	0,87	89,3	89,3	88,5	7,7	2,5	3,2	1,0	3,4	0,13	268,0
22	GGIExd 180 L 4b	IE1	1470	42,5	142,9	0,83	89,9	89,9	89	8,3	2,7	2,7	0,9	3,8	0,15	294,2
30	C.GGIExd 180 L 4c	IE1	1470	53,7	194,9	0,89	90,7	90,7	89,7	7,8	2,5	2,8	0,9	2,8	0,15	294,2
30	GGIExd 200 L 4a	IE1	1470	53,5	194,9	0,89	90,7	90,7	90	7,8	2,5	2,8	0,9	2,8	0,22	350
37	C.GGIExd 200 L 4b	IE1	1470	67	240,4	0,87	91,2	91,2	90,5	7,2	2,3	3	1	3	0,227	368
37	GGIExd 225 M 4a	IE1	1470	67	240,4	0,87	91,2	91,2	90,2	7,2	2,3	3	1	3	0,36	441,3
45	GGIExd 225 M 4b	IE1	1470	80	292,3	0,89	91,7	91,7	91	7,3	2,5	3,1	1,0	2,9	0,36	441,3
55	C.GGIExd 225 M 4c	IE1	1470	96	356,1	0,90	92,1	92,1	91,2	7,6	2,5	3,1	1,0	2,9	0,4	445
55	GGIExd 250 M 4a	IE1	1475	96,8	356,1	0,89	92,1	92,1	91,1	7,6	2,5	3,1	1,0	2,9	0,54	512,7
75	C.GGIExd 250 M 4b	IE1	1475	132,1	487,9	0,88	92,7	92,7	91,7	7,5	2,5	3,1	1,0	2,7	0,73	579,8

Efficiency values are calculated by indirect measurement method in accordance with IEC 60034-2-1:2014. Additional losses are determined according to test results at variable load values.

3 Phase, 400 V, 50 Hz, IE1



Duty Type
S1 (Continuous Operation)



Protection Class
IP 65



Insulation Class
F (155°C)



Temperature Rise
B (80 K)



Rated Power	Type	Efficiency Class	At Rated Power							At Starting				Breakdown Torque Ratio	Moment of Inertia	Approx. Weight
			Speed	Current	Torque	Power Coefficient	Efficiency η			Current Ratio		Torque Ratio				
kW			RPM	A	Nm	Cos ϕ	4/4	3/4	1/2	Direct	Y/ Δ	Direct	Y/ Δ			

6 poles - 1000 RPM

0,18	GGIExd 71 M 6a	IE1	880	0,68	2,0	0,84	45,5	45,5	44,5	2,2	-	1,4	-	1,7	0,00064	16,4
0,25	GGIExd 71 M 6b	IE1	905	0,90	2,7	0,77	52,1	52,1	51,1	2,7	-	1,7	-	1,7	0,00086	17,6
0,37	GGIExd 80 M 6a	IE1	930	1,10	3,8	0,81	59,7	59,7	58,7	2,9	-	1,5	-	1,8	0,0017	25,3
0,55	GGIExd 80 M 6b	IE1	940	1,65	5,6	0,73	65,8	65,8	64,8	3,4	-	1,6	-	2,2	0,0022	27,3
0,75	GGIExd 90 S 6a	IE1	945	2,15	7,6	0,72	70	70	69	3,7	-	1,6	-	2,3	1,7	29,3
1,1	GGIExd 90 L 6b	IE1	950	3,1	11,1	0,70	72,9	72,9	71,9	4,1	-	2	-	2,6	1,9	32,8
1,5	GGIExd 100 L 6a	IE1	945	3,6	15,2	0,80	75,2	75,2	75	4,5	-	2,2	-	2,4	0,0077	46,4
2,2	GGIExd 112 M 6a	IE1	950	5,4	22,1	0,76	77,7	77,7	76,7	4,7	-	2,2	-	2,5	0,0092	56,7
3	GGIExd 132 S 6a	IE1	960	7,1	29,8	0,77	79,7	79,7	78,7	4,6	1,5	1,8	0,6	2,3	0,019	80,6
4	GGIExd 132 M 6b	IE1	960	9,3	39,8	0,76	81,4	81,4	80,5	4,7	1,5	2,0	0,6	2,3	0,032	103,2
5,5	GGIExd 132 M 6c	IE1	960	12,7	54,7	0,75	83,1	83,1	82,2	4,9	1,6	2,2	0,7	2,6	0,032	103,2
7,5	GGIExd 160 M 6a	IE1	975	16	73,5	0,80	84,7	84,7	84	6,3	2,0	2,6	0,8	3,5	0,076	157,3
11,0	GGIExd 160 L 6b	IE1	970	22,5	108,3	0,82	86,4	86,4	85,5	6,2	2,0	3,0	1,0	3,0	0,109	181,4
15	GGIExd 180 L 6a	IE1	965	29	148,4	0,85	87,7	87,7	86,7	6,5	2,1	2,4	0,8	3	0,2	277,2
18,5	GGIExd 200 L 6a	IE1	980	37,1	180,3	0,81	88,6	88,6	87,7	7,2	2,3	2,3	0,7	3,2	0,234	327,5
22	GGIExd 200 L 6b	IE1	975	43,7	216,3	0,81	89,2	89,2	88,2	7,1	2,4	2,6	0,9	3,1	0,283	353,3
30	GGIExd 225 M 6a	IE1	980	58	292,3	0,83	90,2	90,2	89,5	7,0	2,3	3,0	1,0	2,6	1,2	421,6
37	C.GGIExd 225 M 6b	IE1	985	71,4	359,9	0,82	90,8	90,8	89,8	6,4	2,1	3,0	1,0	2,2	1,5	425
37	GGIExd 250 M 6a	IE1	985	71,4	358,7	0,82	90,8	90,8	89,8	7,0	2,3	3,0	1,0	2,6	0,77	535,1
45	C.GGIExd 250 M 6b	IE1	980	87	439	0,82	91,4	91,4	90,8	6,5	2,2	3,0	1,0	2,2	0,99	597,7

Efficiency values are calculated by indirect measurement method in accordance with IEC 60034-2-1:2014. Additional losses are determined according to test results at variable load values.

3 Phase, 400 V, 50 Hz, IE1



Duty Type
S1 (Continuous Operation)



Protection Class
IP 65



Insulation Class
F (155°C)



Temperature Rise
B (80 K)



Rated Power kW	Type	Efficiency Class	At Rated Power							At Starting				Breakdown Torque Ratio	Moment of Inertia	Approx. Weight
			Speed	Current	Torque	Power Coefficient	Efficiency η			Current Ratio		Torque Ratio				
			RPM	A	Nm	Cos ϕ	4/4	3/4	1/2	Direct	Y/ Δ	Direct	Y/ Δ			

8 poles - 750 RPM

0,18	GGIExd 80 M 8a	IE1	715	0,8	2,4	0,85	38	38	37,1	2,7	-	1,4	-	2,2	0,0017	25,3
0,25	GGIExd 80 M 8b	IE1	710	1	3,4	0,83	43,4	43,4	42,4	2,8	-	1,4	-	2,1	0,0022	27,3
0,37	GGIExd 90 S 8a	IE1	715	1,45	5,1	0,74	49,7	49,7	48,7	3,2	-	1,5	-	2,2	0,0029	29,9
0,55	GGIExd 90 S 8b	IE1	715	2	7,3	0,71	56,1	56,1	55,1	3,2	-	1,5	-	2,2	0,0029	29,9
18,5	GGIExd 225 M 8a	IE1	740	38,8	239,1	0,79	86,9	86,9	86,1	6,3	2,1	1,7	0,6	1,9	1,2	421,6
22	GGIExd 225 M 8b	IE1	740	44	285,4	0,83	87,4	87,1	84,8	5,8	1,9	1,7	0,6	2,4	1,2	421,6
30	GGIExd 250 M 8a	IE1	740	61,4	390,1	0,80	88,3	88,3	87,3	6,3	2,1	1,9	0,6	2,4	0,92	544

Efficiency values are calculated by indirect measurement method in accordance with IEC 60034-2-1:2014. Additional losses are determined according to test results at variable load values.

3 Phase, 400 V, 50 Hz, IE2-IE3



Duty Type
S1 (Continuous Operation)



Protection Class
IP 65



Insulation Class
F (155°C)



Temperature Rise
B (80 K)

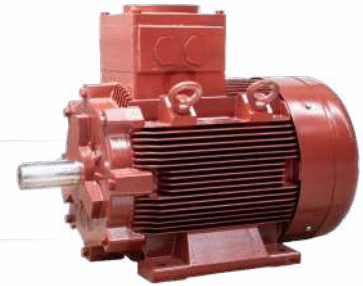

Rated Power	Type	Efficiency Class	At Rated Power							At Starting				Breakdown Torque Ratio	Moment of Inertia	Approx. Weight
			Speed	Current	Torque	Power Coefficient	Efficiency η			Current Ratio		Torque Ratio				
kW			RPM	A	Nm	Cos ϕ	4/4	3/4	1/2	Direct	Y/ Δ	Direct	Y/ Δ			

2 poles - 3000 RPM

0,37	GG2Exd 71 M 2a	IE2	2735	0,94	1,3	0,82	69,5	69,5	68,5	3,6	-	1,7	-	2,2	0,00026	16,4
0,55	GG3Exd 71 M 2b	IE3	2840	1,2	1,9	0,85	77,8	77,8	76,8	5,3	-	2,6	-	3,2	0,00034	17,6
0,75	C.GG3Exd 71 M 2c	IE3	2880	1,7	2,4	0,79	80,7	80,7	79,7	5,9	-	2,9	-	3,6	0,00052	17,7
0,75	GG3Exd 80 M 2a	IE3	2860	1,60	2,5	0,85	80,7	80,6	79,6	5,7	-	2,4	-	3	0,00053	24,3
1,1	GG3Exd 80 M 2b	IE3	2865	2,3	3,7	0,83	82,7	82,7	81,7	5,9	-	2,8	-	3,4	0,00053	24,3
1,5	C.GG3Exd 80 M 2c	IE3	2840	3	5	0,86	84,2	84,2	83,1	5,7	-	2,7	-	3	0,001	27,8
1,5	GG3Exd 90 S 2a	IE3	2890	3,1	5	0,83	84,2	84,2	83,2	6,5	-	2,7	-	3,2	0,0090	31
2,2	GG3Exd 90 L 2b	IE3	2910	4,5	7,2	0,82	85,9	85,9	85,0	7,8	-	3,4	-	3,8	0,0017	27
3	GG3Exd 100 L 2a	IE3	2900	5,80	9,9	0,86	87,1	86,9	85,3	7,6	-	3,4	-	4	0,0025	46,4
4	C.GG3Exd 100 H 2b	IE3	2900	7,2	13,2	0,91	88,1	88,1	87,1	8	-	2,9	-	3,6	0,0039	53,6
4	GG3Exd 112 M 2a	IE3	2920	7,4	13,1	0,89	88,1	88	87,2	7,2	2,3	2,8	0,9	3,5	0,0039	53,6
5,5	GG3Exd 132 S 2a	IE3	2925	10,2	18	0,87	89,2	89,0	87,4	7,2	2,3	2,1	0,7	3	0,013	83,9
7,5	GG3Exd 132 M 2b	IE3	2925	13,5	24,5	0,93	90,1	90,1	89,5	7,6	2,5	2,6	0,8	3,3	0,03	84
11	GG3Exd 160 M 2a	IE3	2950	19,8	35,7	0,92	91,2	91,2	90,4	7,2	2,3	2,2	0,6	3	0,031	180
15	GG3Exd 160 M 2b	IE3	2955	25,7	48,5	0,92	91,9	91,8	91,2	7,9	2,5	2,2	0,7	2,9	0,041	105
18,5	GG3Exd 160 L 2c	IE3	2960	31,4	59,7	0,92	92,4	92,5	92,0	8,1	2,6	2,2	0,7	3,1	0,049	186
22	GG3Exd 180 M 2a	IE3	2960	36,9	71	0,93	92,7	92,6	92,2	8,5	2,7	2,9	0,9	3,4	0,13	268,0
30	GG3Exd 200 L 2a	IE3	2980	52,0	96,1	0,89	93,3	93,3	92,8	8,5	2,7	2,8	0,9	3,5	0,13	360,7
37	GG3Exd 200 L 2b	IE3	2980	63,0	118,6	0,90	93,7	93,7	93,1	8,3	2,7	2,8	0,9	3,1	0,15	386,5
45	GG3Exd 225 M 2a	IE3	2980	77,0	144,2	0,90	94,0	94,1	93,0	8,7	2,8	2,7	0,9	3,1	0,894	400
55	C.GG3Exd 225 M 2b	IE3	2975	91,9	176,5	0,92	94,3	94,3	93,3	8,5	2,8	3	1	3	0,38	441,3
55	GG3Exd 250 M 2a	IE3	2985	92,0	176,0	0,92	94,3	94,5	93,3	8,7	2,9	2,9	1,0	3,0	0,41	553,0

Efficiency values are calculated by indirect measurement method in accordance with IEC 60034-2-1:2014. Additional losses are determined according to test results at variable load values.

3 Phase, 400 V, 50 Hz, IE2-IE3



Duty Type
S1 (Continuous Operation)



Protection Class
IP 65



Insulation Class
F (155°C)



Temperature Rise
B (80 K)



Rated Power kW	Type	Efficiency Class	At Rated Power							At Starting				Breakdown Torque Ratio	Moment of Inertia	Approx. Weight
			Speed	Current	Torque	Power Coefficient	Efficiency η			Current Ratio		Torque Ratio				
			RPM	A	Nm	Cos ϕ	4/4	3/4	1/2	Direct	Y/ Δ	Direct	Y/ Δ			

4 poles - 1500 RPM

0,25	GG2Exd 71 M 4a	IE2	1415	0,73	1,9	0,72	68,5	68,5	67,5	4,5	-	1,7	-	2,2	0,0004	16,4
0,37	GG2Exd 71 M 4b	IE2	1415	1	2,7	0,74	72,7	72,7	71,7	4,1	-	1,8	-	2,3	0,00054	17,6
0,55	C.GG2Exd 71 M 4c	IE2	1405	1,5	4,0	0,69	77,1	77,1	76,1	3,8	-	1,7	-	2,1	0,00062	18,4
0,55	GG3Exd 80 M 4a	IE3	1445	1,5	3,6	0,65	80,8	80,8	79,9	5	-	2,5	-	3	0,00083	25,8
0,75	GG3Exd 80 M 4b	IE3	1425	1,85	5,0	0,71	82,5	82,5	80,8	5	-	2,7	-	2,9	0,0014	28,3
1,1	GG3Exd 90 S 4a	IE3	1450	2,5	7,3	0,76	84,1	84,1	83,1	6,2	-	2,8	-	3,5	0,0093	33
1,5	GG3Exd 90 L 4b	IE3	1450	3,5	9,9	0,75	85,3	85,3	84,3	6,3	-	3,0	-	3,7	0,0109	33
2,2	GG3Exd 100 L 4a	IE3	1445	4,7	14,5	0,78	86,7	86,8	85,0	5,9	-	2,7	-	3,3	0,0044	50,2
3	GG3Exd 100 H 4b	IE3	1445	6,60	19,8	0,75	87,7	87,8	86,1	6,7	-	2,5	-	3,4	0,005	58,6
4	GG3Exd 112 M 4a	IE3	1450	8,00	26,3	0,81	88,6	88,5	88,0	7	2,4	2,8	0,9	3,4	0,0092	58,7
5,5	GG3Exd 132 S 4a	IE3	1450	11,0	36,2	0,81	89,6	89,6	88,8	6	2	2,4	0,9	3	0,021	92,2
7,5	GG3Exd 132 M 4b	IE3	1450	15,1	49,3	0,8	90,4	90,5	89,6	5,9	2	2,5	0,9	2,8	0,026	79
11	GG3Exd 160 M 4a	IE3	1470	21,1	71,5	0,82	91,4	91,3	91,0	6,1	2	1,9	0,6	2,6	0,076	182
15	GG3Exd 160 L 4b	IE3	1475	29,7	97,1	0,79	92,1	92,0	91,8	7,5	2,5	2,5	0,8	3,3	0,0102	185
18,5	GG3Exd 180 M 4a	IE3	1475	34,0	119,8	0,85	92,6	92,6	91,6	8,5	2,7	2,9	0,9	3,9	0,066	259,5
22	GG3Exd 180 L 4b	IE3	1475	39,4	142,4	0,87	93,0	92,8	92,0	7,5	2,4	2,9	1	3,5	0,15	294,2
30	GG3Exd 200 L 4a	IE3	1475	52,8	194,2	0,88	93,6	93,5	93,0	8,2	2,6	2,4	0,8	3	0,227	368
37	C.GG3Exd 200 L 4b	IE3	1475	65,4	240,9	0,87	93,9	93,8	92,9	8,1	2,7	2,9	1	3,3	0,227	368
37	GG3Exd 225 S 4a	IE3	1475	67	239,6	0,85	93,9	93,9	93,5	7,5	2,4	3,1	1	3,3	0,48	468
45	GG3Exd 225 M 4b	IE3	1475	80,0	291,4	0,86	94,2	94,2	93,4	7,4	2,4	3	1	3,1	0,48	468
55	C.GG3Exd 225 M 4c	IE3	1480	95,8	354,7	0,88	94,6	94,6	93,6	9	3	3,9	1,3	3,5	0,72	445
55	GG3Exd 250 M 4a	IE3	1480	96,0	354,9	0,87	94,6	94,7	94,0	7,7	2,6	3,2	1,1	3,0	0,72	597,7

Efficiency values are calculated by indirect measurement method in accordance with IEC 60034-2-1:2014. Additional losses are determined according to test results at variable load values.

3 Phase, 400 V, 50 Hz, IE2-IE3



Duty Type
S1 (Continuous Operation)



Protection Class
IP 65



Insulation Class
F (155°C)



Temperature Rise
B (80 K)



Rated Power	Type	Efficiency Class	At Rated Power							At Starting				Breakdown Torque Ratio	Moment of Inertia	Approx. Weight
			Speed	Current	Torque	Power Coefficient	Efficiency η			Current Ratio		Torque Ratio				
kW			RPM	A	Nm	Cos ϕ	4/4	3/4	1/2	Direct	Y/ Δ	Direct	Y/ Δ			

6 poles - 1000 RPM

0,18	GG2Exd 71 M 6a	IE2	880	0,68	2,0	0,68	56,6	56,6	55,6	2,2	-	1,4	-	1,7	0,00064	16,4
0,25	GG2Exd 71 M 6b	IE2	905	0,90	2,7	0,65	61,6	61,6	60,6	2,7	-	1,7	-	1,7	0,00086	17,6
0,37	GG2Exd 80 M 6a	IE2	930	1,10	3,8	0,72	67,6	67,6	66,6	2,9	-	1,5	-	1,8	0,0017	25,3
0,55	GG2Exd 80 M 6b	IE2	940	1,65	5,6	0,66	73,1	73,1	72,1	3,4	-	1,6	-	2,2	0,0022	27,3
0,75	GG3Exd 90 S 6a	IE3	950	2	7,6	0,69	78,9	78,9	77,9	4,1	-	1,7	-	2,3	0,0093	33
1,1	GG3Exd 90 L 6b	IE3	950	3	11,1	0,68	81	81	80	4,4	-	2,0	-	2,6	0,0109	33
1,5	GG3Exd 100 L 6a	IE3	955	3,60	15	0,73	82,5	82,3	80,3	5,1	-	2,4	-	3	0,0077	46,4
2,2	GG3Exd 112 M 6a	IE3	960	5,30	21,9	0,71	84,3	84,1	82,1	5,8	-	2,6	-	3,2	0,0092	58,7
3	GG3Exd 132 S 6a	IE3	960	7,1	29,8	0,71	85,6	85,6	84,5	5,4	1,7	2,1	0,7	2,9	0,019	80,6
4	GG3Exd 132 M 6b	IE3	975	10,2	39,2	0,65	86,8	86,7	86,4	5,6	1,8	2,5	0,8	3,1	0,026	79
5,5	GG3Exd 132 M 6c	IE3	975	13,7	53,9	0,66	88,0	87,8	87,5	5,9	1,9	2,6	0,8	3,3	0,026	79
7,5	GG3Exd 160 M 6a	IE3	970	16,2	73,8	0,75	89,1	89,0	88,1	6,7	2,2	2,6	0,8	3,4	0,091	185
11	GG3Exd 160 L 6b	IE3	975	22,7	107,7	0,77	90,3	90,3	89,0	7,1	2,3	2,5	0,8	3,4	0,13	188
15	GG3Exd 180 L 6a	IE3	975	28,7	147	0,83	91,2	91,2	90,8	8	2,6	2,2	0,7	3,2	0,2	277,2
18,5	GG3Exd 200 L 6a	IE3	980	37,5	180,3	0,78	91,7	91,6	91,3	7,9	2,5	2,6	0,9	3,7	0,227	368
22	GG3Exd 200 L 6b	IE3	980	42,2	214,4	0,82	92,2	92,0	91,7	6,8	2,2	1,9	0,7	3,1	0,227	368
30	GG3Exd 225 M 6a	IE3	985	58,0	290,9	0,80	92,9	92,9	92,1	7	2,3	3,3	1,1	2,7	0,69	480
37	C.GG3Exd 225 M 6b	IE3	985	70,5	358,8	0,81	93,3	93,3	92,3	6,9	2,3	2,8	0,9	2,5	0,69	480
37	GG3Exd 250 M 6a	IE3	985	70,0	358,7	0,82	93,3	93,2	92,9	7,0	2,3	2,8	0,9	2,6	0,77	535,1
45	C.GG3Exd 250 M 6b	IE3	990	87,7	435,5	0,80	93,7	93,7	92,7	7,8	2,6	3,1	1,0	3,1	0,77	535,1

Efficiency values are calculated by indirect measurement method in accordance with IEC 60034-2-1:2014. Additional losses are determined according to test results at variable load values.

3 Phase, 400 V, 50 Hz, IE3



Duty Type
S1 (Continuous Operation)



Protection Class
IP 65



Insulation Class
F (155°C)



Temperature Rise
B (80 K)



Rated Power	Type	Efficiency Class	At Rated Power							At Starting				Breakdown Torque Ratio	Moment of Inertia	Approx. Weight
			Speed	Current	Torque	Power Coefficient	Efficiency η			Current rate		Torque Ratio				
			RPM	A	Nm	Cos ϕ	4/4	3/4	1/2	Direct	Y/ Δ	Direct	Y/ Δ			
kW																

8 poles - 750 RPM

0,18	GG3Exd 80 M 8a	IE3	715	0,8	2,4	0,55	58,7	58,7	57,5	2,7	-	1,4	-	2,2	0,0017	25,3
0,25	GG3Exd 80 M 8b	IE3	710	1	3,4	0,56	64,1	64,1	63,1	2,8	-	1,4	-	2,1	0,0022	27,3
0,37	GG3Exd 90 S 8a	IE3	715	1,45	5,1	0,53	69,3	69,3	68,3	3,2	-	1,5	-	2,2	0,0093	33
0,55	GG3Exd 90 S 8b	IE3	715	2	7,3	0,55	73	73	72	3,2	-	1,5	-	2,2	0,0093	32
0,75	GG3Exd 100 L 8a	IE3	710	2,3	10,1	0,63	75,0	75,0	74,0	3,7	-	1,9	-	2,3	0,0077	46,4
1,1	GG3Exd 100 H 8b	IE3	715	3,4	14,7	0,60	77,7	77,7	76,7	4,2	-	2,1	-	2,7	0,005	58,6
1,5	GG3Exd 112 M 8a	IE3	710	4,4	20,1	0,62	79,7	79,7	78,7	4,1	-	2,2	-	2,6	0,0092	58,7
2,2	GG3Exd 132 S 8a	IE3	705	5,2	29,8	0,75	81,9	81,2	81,1	4,5	1,5	2,4	0,8	2,7	0,019	80,6
3	GG3Exd 132 M 8b	IE3	700	6,9	41,0	0,75	83,5	83,5	82,5	4,4	1,5	2,4	0,8	2,6	0,025	78
4	GG3Exd 160 M 8a	IE3	710	9,2	53,6	0,74	84,8	84,8	83,8	4,3	1,4	1,8	0,6	2,2	0,06	180,0
5,5	GG3Exd 160 M 8b	IE3	720	12,9	73,1	0,72	86,2	86,2	85,0	5,4	1,8	2,4	0,8	3,0	0,083	180,0
7,5	GG3Exd 160 L 8c	IE3	720	17,65	99,8	0,70	87,3	87,6	86,3	1,9	0,6	2,0	0,7	2,1	0,15	190,0
11	GG3Exd 180 L 8a	IE3	725	23,2	145,3	0,78	88,6	88,6	87,7	6,4	2,1	2,8	0,9	3,4	0,2	277,2
15	GG3Exd 200 L 8a	IE3	725	31,2	197,2	0,77	89,6	89,6	88,6	6,1	2,0	2,3	0,8	3,1	0,227	368
18,5	GG3Exd 225 M 8a	IE3	740	38,8	239,1	0,76	90,1	90,1	89,3	6,3	2,1	1,7	0,6	1,9	0,69	480
22	GG3Exd 225 M 8b	IE3	735	44,1	285,4	0,80	90,6	90,7	90	5,8	1,9	1,7	0,6	2,4	0,69	480
30	GG3Exd 250 M 8a	IE3	740	61,4	390,1	0,77	91,3	91,3	90,3	6,3	2,1	1,9	0,6	2,4	0,77	535,1

Efficiency values are calculated by indirect measurement method in accordance with IEC 60034-2-1:2014. Additional losses are determined according to test results at variable load values.

EX-PROOF MOTORS / MOTOR DIMENSIONS

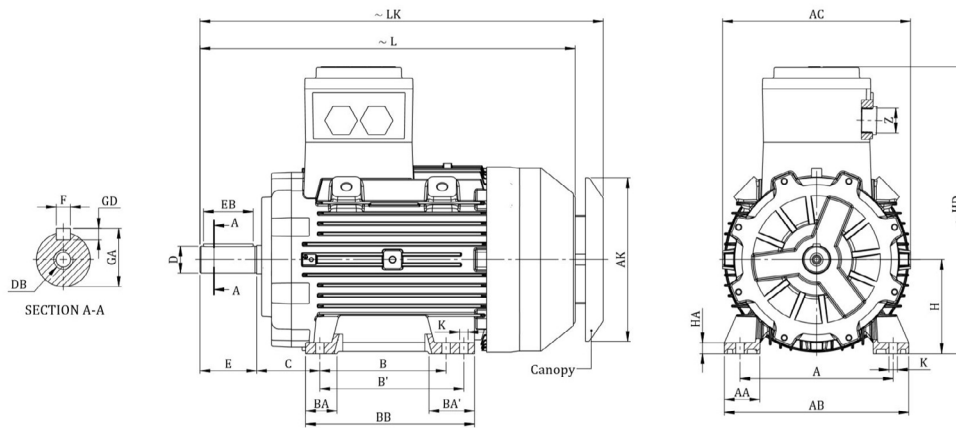

FOOT MOUNTED MOTOR - B3, B6, B7, B8, B15, V5, V6

Frame Size	Pole	H (1)	HD -	HA	A	AA	AB	ACØ	AKØ	KØ	B	B'	BA	BA'	BB	L -	LK -	C	E (2)	EB	DB (5)	DØ (4)	GA	F x GD (3)	Blank Plug
71-M	2-4-6-8	71	232	10	112	28	140	142	116	7	90	-	33	33	110	293	322	45	30	22	M5	14	16	5 x 5	M25 x 1,5
80-M	2-4-6-8	80	270	10	125	34	160	165	151	10	100	-	41	41	125	336	365	50	40	32	M6	19	21,5	6 x 6	M25 x 1,5
90-S	2-4-6-8	90	290	12	140	37,5	180	180	151	10	100	-	39	39	125	346	375	56	50	40	M8	24	27	8 x 7	M25 x 1,5
90-L	2-4-6-8	90	290	12	140	37,5	180	180	151	10	125	-	39	39	150	366	395	56	50	40	M8	24	27	8 x 7	M25 x 1,5
100-L	2-4-6-8	100	310	16	160	40	200	196,5	189	12	140	-	42	52	185	423	460	63	60	50	M10	28	31	8 x 7	M25 x 1,5
100-LH	2-4-6-8	100	310	16	160	40	200	196,5	189	12	140	-	40	50	185	473	510	63	60	50	M10	28	31	8 x 7	M25 x 1,5
112-M	2-4-6-8	112	332	15	190	51	230	225	189	12	140	-	49	49	175	462	499	70	60	50	M10	28	31	8 x 7	M25 x 1,5
132-S	2-4-6-8	132	403	15	216	50	260	265	239	12	140	-	44	44	180	509	546	89	80	70	M12	38	41	10 x 8	2 Pcs. M32 x 1,5
132-M	2-4-6-8	132	403	15	216	50	260	265	239	12	178	-	44	44	218	529	566	89	80	70	M12	38	41	10 x 8	2 Pcs. M32 x 1,5
160-M	2-4-6-8	160	484	22	254	63,5	312	320	303	15	210	-	71	71	260	650	707	108	110	90	M16	42	45	12 x 8	2 Pcs. M40 x 1,5
160-L	2-4-6-8	160	484	22	254	63,5	312	320	303	15	254	-	71	71	304	694	751	108	110	90	M16	42	45	12 x 8	2 Pcs. M40 x 1,5
180-M	2-4-6-8	180	551	24	279	74	354	354	303	15	241	-	80	80	291	700	757	121	110	100	M16	48	51,5	14 x 9	2 Pcs. M40 x 1,5
180-L	2-4-6-8	180	551	24	279	74	354	354	303	15	279	-	80	80	329	726	783	121	110	100	M16	48	51,5	14 x 9	2 Pcs. M40 x 1,5
200-L	2-4-6-8	200	611	26	318	80	398	394	370	19	305	-	80	80	355	874	930	133	110	100	M20	55	59	16 x 10	2 Pcs. M50 x 1,5
225-MS 2		225	671	30	356	82	438	448	370	19	286	311	77,5	102,5	371	906	962	149	110	100	M20	55	59	16 x 10	2 Pcs. M50 x 1,5
225-MS 4-6-8		225	671	30	356	82	438	448	370	19	286	311	77,5	102,5	371	936	992	149	140	125	M20	60	64	18 x 11	2 Pcs. M50 x 1,5
250-M 2		250	696	35	406	105	484	483	440	24	349	-	90	90	429	917	973	168	140	125	M20	60	64	18 x 11	2 Pcs. M63 x 1,5
250-M 4-6-8		250	696	35	406	105	484	483	440	24	349	-	90	90	429	917	973	168	140	125	M20	65	69	18 x 11	2 Pcs. M63 x 1,5

- 1) Tolerance EN IEC 60072-1 " E (0 / -0,5) "
- 2) Tolerance EN IEC 60072-1 " F (h9) "
- 3) Tolerance EN IEC 60072-1 " DØ (j6) ≤ 28", "28 < DØ (k6) ≤ 48", "48 < DØ (m6)"
- 4) Tolerance EN IEC 60072-1 " NØ (j6) ≤ 250", "250 < DØ (h6)"
- 5) DB: DIN 332-2 Form D
- 6) "Note: The spindle collar and flange seating surface are in the same plane." R = 0

EX-PROOF MOTORS/ MOTOR DIMENSIONS

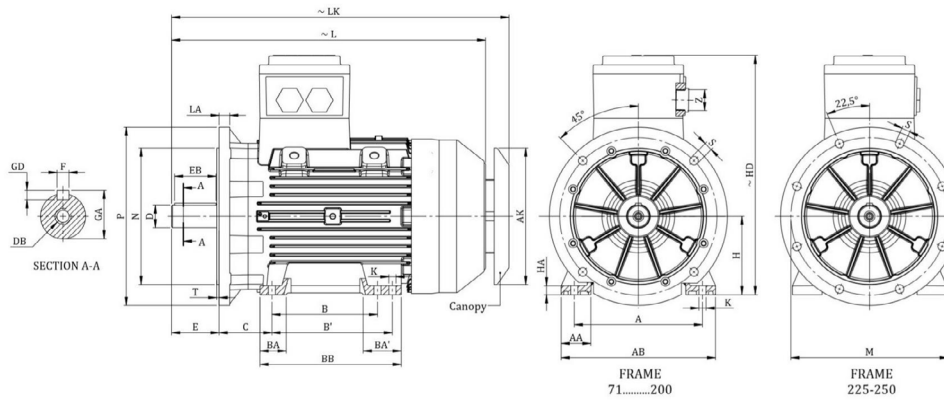

FLANGED MOTOR (FORM A) - B5, V1, V3

Frame Size	Pole	Flange No	MØ	NØ (4)	PØ	No	SØ	T	LA	AD	AKØ	L	LK	E (1)	EB	DB (5)	DØ (3)	GA	F x GD (3)	Blank Plug
71-M	2-4-6-8	FF130	130	110	160	4	10	3,5	10	161	116	293	322	30	22	M5	14	16	5 x 5	M25 x 1,5
80-M	2-4-6-8	FF165	165	130	200	4	12	3,5	12	190	151	336	365	40	32	M6	19	21,5	6 x 6	M25 x 1,5
90-S	2-4-6-8	FF165	165	130	200	4	12	3,5	12	200	151	346	375	50	40	M8	24	27	8 x 7	M25 x 1,5
90-L	2-4-6-8	FF165	165	130	200	4	12	3,5	12	200	151	366	395	50	40	M8	24	27	8 x 7	M25 x 1,5
100-L	2-4-6-8	FF215	215	180	250	4	14,5	4	15	210	189	423	460	60	50	M10	28	31	8 x 7	M25 x 1,5
100-LH	2-4-6-8	FF215	215	180	250	4	14,5	4	15	210	189	473	510	60	50	M10	28	31	8 x 7	M25 x 1,5
112-M	2-4-6-8	FF215	215	180	250	4	14,5	4	15	220	189	462	499	60	50	M10	28	31	8 x 7	M25 x 1,5
132-S	2-4-6-8	FF265	265	230	300	4	14,5	4	20	271	239	509	546	80	70	M12	38	41	10 x 8	2 Pcs. M32 x 1,5
132-M	2-4-6-8	FF265	265	230	300	4	14,5	4	20	271	239	529	566	80	70	M12	38	41	10 x 8	2 Pcs. M32 x 1,5
160-M	2-4-6-8	FF300	300	250	350	4	18,5	5	20	324	303	650	707	110	90	M16	42	45	12 x 8	2 Pcs. M40 x 1,5
160-L	2-4-6-8	FF300	300	250	350	4	18,5	5	20	324	303	694	751	110	90	M16	42	45	12 x 8	2 Pcs. M40 x 1,5
180-M	2-4-6-8	FF300	300	250	350	4	18,5	5	20	371	303	700	757	110	100	M16	48	51,5	14 x 9	2 Pcs. M40 x 1,5
180-L	2-4-6-8	FF300	300	250	350	4	18,5	5	20	371	303	726	783	110	100	M16	48	51,5	14 x 9	2 Pcs. M40 x 1,5
200-L	2-4-6-8	FF350	350	300	400	4	18,5	5	20	411	370	874	930	110	100	M20	55	59	16 x 10	2 Pcs. M50 x 1,5
225-MS 2		FF400	400	350	450	8	18,5	5	20	446	370	906	962	110	100	M20	55	59	16 x 10	2 Pcs. M50 x 1,5
225-MS 4-6-8		FF400	400	350	450	8	18,5	5	20	466	370	936	992	140	125	M20	60	64	18 x 11	2 Pcs. M50 x 1,5

1) Tolerance EN IEC 60072-1 " E (0 / -0,5) "
 2) Tolerance EN IEC 60072-1 " F (h9) "
 3) Tolerance EN IEC 60072-1 " DØ (j6) ≤ 28", "28 < DØ (k6) ≤ 48", "48 < DØ (m6)"
 4) Tolerance EN IEC 60072-1 " NØ (j6) ≤ 250", "250 < DØ (h6)"
 5) DB: DIN 332-2 Form D
 6) "Note: The spindle collar and flange seating surface are in the same plane." R = 0

All dimensions are in mm.

EX-PROOF MOTORS / MOTOR DIMENSIONS

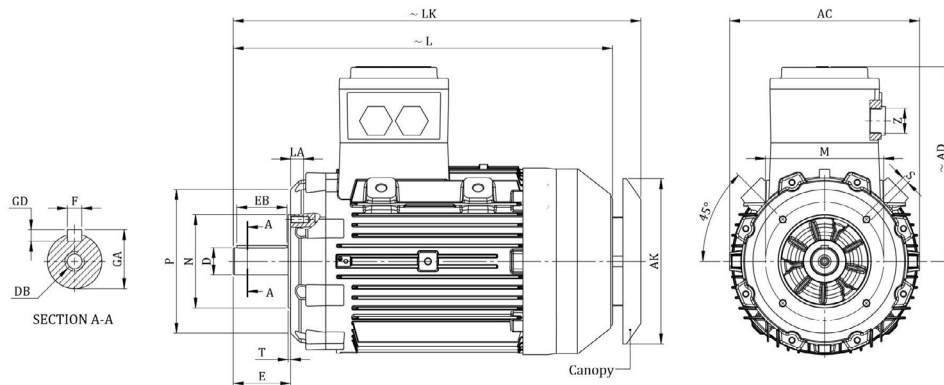

FLANGED MOTOR (FORM C) - B14, V18, V19

Frame Size	Pole	Flange No	MØ	NØ (4)	PØ	SØ	T	LA	ACØ	AD	AKØ	L	LK	E (1)	EB	DB (5)	DØ (3)	GA	F x GD (3)	Blank Plug
71-M	2-4-6-8	FT 85	85	70	105	M6	2,5	12												
		FT 115	115	95	140	M8	3	16	142	161	116	293	322	30	22	M5	14	16	5 x 5	M25 x 1,5
80-M	2-4-6-8	FT 100	100	80	120	M6	3	12												
		FT 130	130	110	160	M8	3,5	16	165	190	151	336	365	40	32	M6	19	21,5	6 x 6	M25 x 1,5
90-S	2-4-6-8	FT 115	115	95	140	M8	3	16												
		FT 130	130	110	160	M8	3,5	16	180	200	151	346	375	50	40	M8	24	27	8 x 7	M25 x 1,5
90-L	2-4-6-8	FT 115	115	95	140	M8	3	16												
		FT 130	130	110	160	M8	3,5	16	180	200	151	366	395	50	40	M8	24	27	8 x 7	M25 x 1,5
100-L	2-4-6-8	FT 130	130	110	160	M8	3,5	16												
		FT 165	165	130	200	M10	3,5	20	196,5	210	189	423	460	60	50	M10	28	31	8 x 7	M25 x 1,5
100-LH	2-4-6-8	FT 130	130	110	160	M8	3,5	16												
		FT 165	165	130	200	M10	3,5	20	196,5	210	189	473	510	60	50	M10	28	31	8 x 7	M25 x 1,5
112-M	2-4-6-8	FT 130	130	110	160	M8	3,5	16												
		FT 165	165	130	200	M10	3,5	20	225	220	189	462	499	60	50	M10	28	31	8 x 7	M25 x 1,5
132-S	2-4-6-8	FT 165	165	130	200	M10	3,5	20												
		FT 215	215	180	250	M12	4	20	265	271	239	509	546	80	70	M12	38	41	10 x 8	2 Pcs. M32 x 1,5
132-M	2-4-6-8	FT 165	165	130	200	M10	3,5	20												
		FT 215	215	180	250	M12	4	20	265	271	239	529	566	80	70	M12	38	41	10 x 8	2 Pcs. M32 x 1,5
160-M	2-4-6-8	FT 215	215	180	250	M12	4	20	320	324	303	650	707	110	90	M16	42	45	12 x 8	2 Pcs. M40 x 1,5
160-L	2-4-6-8	FT 215	215	180	250	M12	4	20	320	324	303	694	751	110	90	M16	42	45	12 x 8	2 Pcs. M40 x 1,5

1) Tolerance EN IEC 60072-1 " E (0 / -0,5) "

2) Tolerance EN IEC 60072-1 " F (h9) "

3) Tolerance EN IEC 60072-1 " DØ (j6) ≤ 28", "28 < DØ (k6) ≤ 48", "48 < DØ (m6)"

4) Tolerance EN IEC 60072-1 " NØ (j6) ≤ 250", "250 < DØ (h6)"

5) DB DIN 332-2 Form

6) "Note: The spindle collar and flange seating surface are in the same plane." R = 0

EX-PROOF MOTORS / MOTOR DIMENSIONS

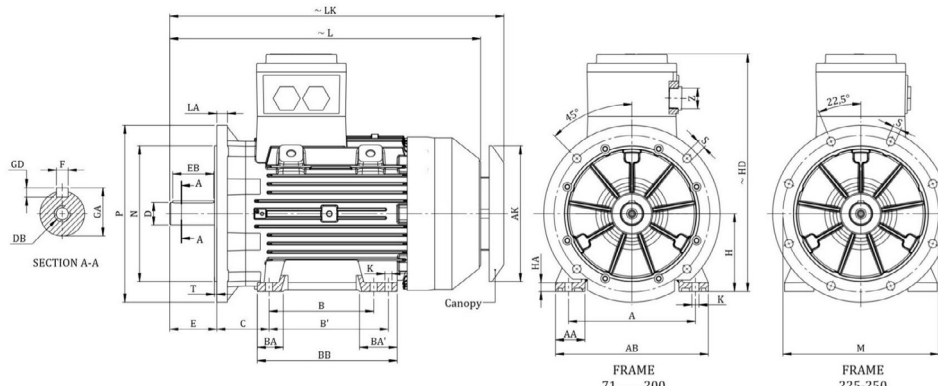

FOOT MOUNTED AND FLANGED MOTOR - B35

Frame Size	Pole	H (1)	HD -	HA	A	AA	AB	AKØ	KØ	B	B'	BA	BA'	BB	Flange No	MØ	NØ (5)	PØ	No	SØ	T	LA	L	LK -	C	E (2)	EB	DB (6)	DØ (4)	GA	F x GD (3)	Blank Plug
71-M	2-4-6-8	71	232	10	112	28	140	116	7	90	-	33	33	110	FF130	130	110	160	4	10	3,5	10	293	322	45	30	22	M5	14	16	5 x 5	M25 x 1,5
80-M	2-4-6-8	80	270	10	125	34	160	151	10	100	-	41	41	125	FF165	165	130	200	4	12	3,5	12	336	365	50	40	32	M6	19	21,5	6 x 6	M25 x 1,5
90-S	2-4-6-8	90	290	12	140	37,5	180	151	10	100	-	39	39	125	FF165	165	130	200	4	12	3,5	12	346	375	56	50	40	M8	24	27	8 x 7	M25 x 1,5
90-L	2-4-6-8	90	290	12	140	37,5	180	151	10	125	-	39	39	150	FF165	165	130	200	4	12	3,5	12	366	395	56	50	40	M8	24	27	8 x 7	M25 x 1,5
100-L	2-4-6-8	100	310	16	160	40	200	189	12	140	-	42	52	185	FF215	215	180	250	4	14,5	4	15	423	460	63	60	50	M10	28	31	8 x 7	M25 x 1,5
100-LH	2-4-6-8	100	310	16	160	40	200	189	12	140	-	40	50	185	FF215	215	180	250	4	14,5	4	15	473	510	63	60	50	M10	28	31	8 x 7	M25 x 1,5
112-M	2-4-6-8	112	332	15	190	51	230	189	12	140	-	49	49	175	FF215	215	180	250	4	14,5	4	15	462	499	70	60	50	M10	28	31	8 x 7	M25 x 1,5
132-S	2-4-6-8	132	403	15	216	50	260	239	12	140	-	44	44	180	FF265	265	230	300	4	14,5	4	20	509	546	89	80	70	M12	38	41	10 x 8	2 Pcs. M32 x 1,5
132-M	2-4-6-8	132	403	15	216	50	260	239	12	178	-	44	44	218	FF265	265	230	300	4	14,5	4	20	529	566	89	80	70	M12	38	41	10 x 8	2 Pcs. M32 x 1,5
160-M	2-4-6-8	160	484	22	254	63,5	312	303	15	210	-	71	71	260	FF300	300	250	350	4	18,5	5	20	650	707	108	110	90	M16	42	45	12 x 8	2 Pcs. M40 x 1,5
160-L	2-4-6-8	160	484	22	254	63,5	312	303	15	254	-	71	71	304	FF300	300	250	350	4	18,5	5	20	694	751	108	110	90	M16	42	45	12 x 8	2 Pcs. M40 x 1,5
180-M	2-4-6-8	180	551	24	279	74	354	303	15	241	-	80	80	291	FF300	300	250	350	4	18,5	5	20	700	757	121	110	100	M16	48	51,5	14 x 9	2 Pcs. M40 x 1,5
180-L	2-4-6-8	180	551	24	279	74	354	303	15	279	-	80	80	329	FF300	300	250	350	4	18,5	5	20	726	783	121	110	100	M16	48	51,5	14 x 9	2 Pcs. M40 x 1,5
200-L	2-4-6-8	200	611	26	318	80	398	370	19	305	-	80	80	355	FF350	350	300	400	4	18,5	5	20	874	930	133	110	100	M20	55	59	16 x 10	2 Pcs. M50 x 1,5
225-MS 2		225	671	30	356	82	438	370	19	286	311	77,5	102,5	371	FF400	400	350	450	8	18,5	5	20	906	962	149	110	100	M20	55	59	16 x 10	2 Pcs. M50 x 1,5
225-MS 4-6-8		225	671	30	356	82	438	370	19	286	311	77,5	102,5	371	FF400	400	350	450	8	18,5	5	20	936	992	149	140	125	M20	60	64	18 x 11	2 Pcs. M50 x 1,5

1) Tolerance EN IEC 60072-1 " H (0 / -0,5) "
 2) Tolerance EN IEC 60072-1 " E (0 / -0,5) "
 3) Tolerance EN IEC 60072-1 " F (h9) "
 4) Tolerance EN IEC 60072-1 " DØ (j6) ≤ 28", "28 < DØ (k6) ≤ 48", "48 < DØ (m6) "
 5) Tolerance EN IEC 60072-1 " NØ (j6) ≤ 250", "250 < DØ (h6) "
 6) DB: DIN 332-2 Form D
 7) "Note: The spindle collar and flange seating surface are in the same plane." R = 0

EX-PROOF MOTORS / MOTOR DIMENSIONS

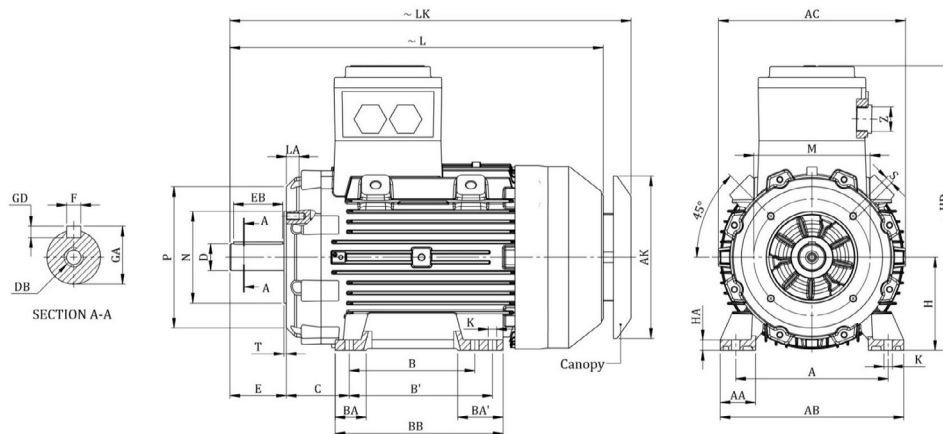

FLANGED MOTOR - B34

Frame Size	Pole	H (1)	HD	HA	A	AA	AB	AC	AK	KØ	B	B'	BA	BA'	BB	Flange No	MØ	NØ (5)	PØ	SØ	T	LA	L	LK	C	E (2)	EB	DB (6)	DØ (4)	GA	F x GD (3)	Blank Plug
71-M	2-4-6-8	71	232	10	112	28	140	142	116	7	90	-	33	33	110	FT 85	85	70	105	M6	2,5	12	293	322	45	30	22	M5	14	16	5 x 5	M25 x 1,5
80-M	2-4-6-8	80	270	10	125	34	160	165	151	10	100	-	41	41	125	FT 100	100	80	120	M6	3	12	336	365	50	40	32	M6	19	21,5	6 x 6	M25 x 1,5
90-S	2-4-6-8	90	290	12	140	37,5	180	180	151	10	100	-	39	39	125	FT 115	115	95	140	M8	3	16	346	375	56	50	40	M8	24	27	8 x 7	M25 x 1,5
90-L	2-4-6-8	90	290	12	140	37,5	180	180	151	10	125	-	39	39	150	FT 115	115	95	140	M8	3	16	366	395	56	50	40	M8	24	27	8 x 7	M25 x 1,5
100-L	2-4-6-8	100	310	16	160	40	200	196,5	189	12	140	-	42	52	185	FT 130	130	110	160	M8	3,5	16	423	460	63	60	50	M10	28	31	8 x 7	M25 x 1,5
100-LH	2-4-6-8	100	310	16	160	40	200	196,5	189	12	140	-	40	50	185	FT 130	130	110	160	M8	3,5	16	473	510	63	60	50	M10	28	31	8 x 7	M25 x 1,5
112-M	2-4-6-8	112	332	15	190	51	230	225	189	12	140	-	49	49	175	FT 165	165	130	200	M10	3,5	20	462	499	70	60	50	M10	28	31	8 x 7	M25 x 1,5
132-S	2-4-6-8	132	403	15	216	50	260	265	239	12	140	-	44	44	180	FT 165	165	130	200	M10	3,5	20	509	546	89	80	70	M12	38	41	10 x 8	2 Pcs. M32 x 1,5
132-M	2-4-6-8	132	403	15	216	50	260	265	239	12	178	-	44	44	218	FT 215	215	180	250	M12	4	20	529	566	89	80	70	M12	38	41	10 x 8	2 Pcs. M32 x 1,5
160-M	2-4-6-8	160	484	22	254	63,5	312	320	303	15	210	-	71	71	260	FT 215	215	180	250	M12	4	20	650	707	108	110	90	M16	42	45	12 x 8	2 Pcs. M40 x 1,5
160-L	2-4-6-8	160	484	22	254	63,5	312	320	303	15	254	-	71	71	304	FT 215	215	180	250	M12	4	20	694	751	108	110	90	M16	42	45	12 x 8	2 Pcs. M40 x 1,5

- 1) Tolerance EN IEC 60072-1 " H (0 / -0,5) "
- 2) Tolerance EN IEC 60072-1 " E (0 / -0,5) "
- 3) Tolerance EN IEC 60072-1 " F (h9) "
- 4) Tolerance EN IEC 60072-1 " DØ (j6) ≤ 28"; "28 < DØ (k6) ≤ 48"; "48 < DØ (m6)"
- 5) Tolerance EN IEC 60072-1 " NØ (j6) ≤ 250"; "250 < DØ (h6)"
- 6) DB: DIN 332-2 Form D
- 7) "Note: The spindle collar and flange seating surface are in the same plane." R = 0

GAMAK EX-PROOF MOTORS

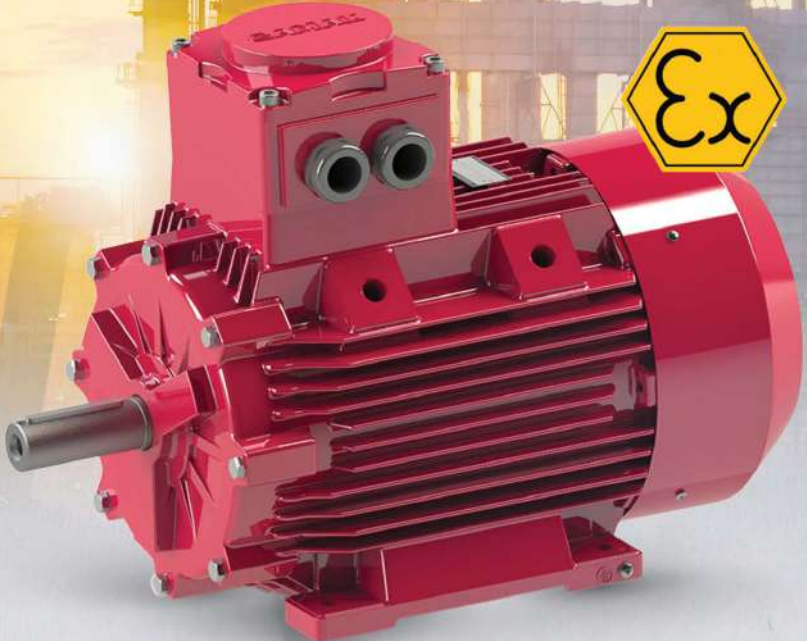

ATEX-22 MOTORS

Special
Series



ATEX 22 MOTORS

II 3D Ex tc IIIB T135°C Dc

Atex 22 motors are dust explosion proof motors suitable for Zone 22. Zone 22 Under normal operating conditions, it represents places where there is no possibility of combustible dust clouds in the air creating an explosive environment, but even if there is such a possibility, it is only valid for a very short time. 71-250 frame are made of aluminum and 250-355 frame are made of cast iron. 0.55-500 kW wide power range. B3, B5, B35, B35, B14, B34, B14/2, B34/2 installation arrangements. Atex 22 Motors meet Atex certification requirements according to the 60079-0 and 60079-31 standards.

Atex 22 Motor Feature	
Power Range	0,55 - 500 kW
Pole	2-4-6-8
Efficiency	IE3
Frame	71-355
Frame Material	Aluminum-Cast Iron
IP	65
Dust Classification	IIIB
Protection Type	Tc (Dust)
Insulation Class	F(155°C) - H(180°C)
Heat Rise Class	B (80K)
Cooling Method	TEFC - IC 411
Operating Temperature	-20°C / +40°C
Paint	RAL 3009
Voltage	220-690 V / 50-60 Hz

Applications of Atex 22 Motors:

Suitable for use in the presence of non-conductive dusts such as flour, grain, wood and plastics, and flammable fibers / flyings such as cotton lint, linen and rayon. Gamak Atex 22 motors can be used in flour and grain mills, wood and plastic production, textiles, etc. or in areas where explosive dust is rarely or only briefly present (Zone 22).



CRUSHER MOTORS



Special
Series



CRUSHER MOTORS

Gamak Crusher motors are designed to withstand the heavy working conditions required by the industry from 110 kW to 400 kW in 315 and 355 frames. The crushing motors, which are designed in cast iron frame with fixed legs, can also be supplied with a HT code structure in 315 frame upon request.

IP65 protection, which is especially needed in extremely dusty environments, is protected by a special seal and bearing design. Lubricated NU bearing used in shaft output, H class insulation, shaft design with increased resistance against extreme fatigue and torsion (shaft diameter 100 millimeters), cast iron frame structure resistant to impacts and falls, thermistor protection are standard features. Thanks to its electrical design suitable for working with a driver, it also responds to speed control needs.

Crusher Motors Features

Power Range	110-400 kW
Pole	4-6
Efficiency	IE3-IE4
Frame	315-355
Frame Material	Cast Iron
Protection Class	IP65
Insulation Class	H
Cooling Mode	IC 411-TEFC
Installation arrangement	B3

The following applications can be listed as the main application areas:

- Stone Crushing
- Feeders and Feed Conveyors
- Crushers
- Sieves
- Disruptors
- Vibration



**POWER
TO
ENERGIZE
LIFE**

CRUSHER MOTORS / SPARE PARTS

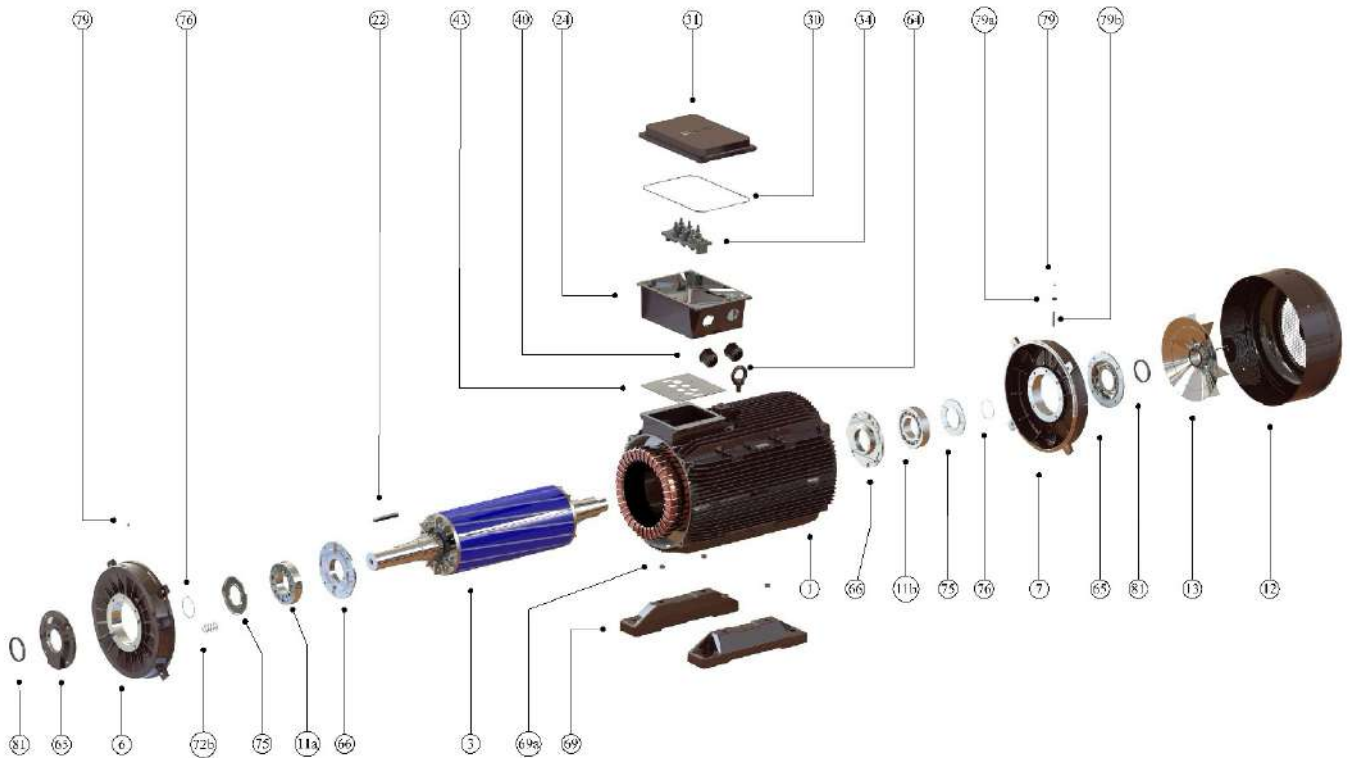

- | | |
|-----|--|
| 1 | Stator with Complete Windings: Varnished and installed to the body |
| 3 | Complete Rotor: With balanced, shaft, machined (excluding keys) |
| 6 | Front End-Shields |
| 7 | Rear End-Shields |
| 11a | Front Bearing (Cylindrical Roller-NU Bearing) |
| 11b | Rear Bearing |
| 12 | Fan Housing Bowl |
| 13 | Cooling Fan |
| 22 | Shaft End Wedge |
| 24 | Terminal Box |
| 30 | Seal (Between Terminal Box and End-Shields) |
| 31 | Terminal Box End-Shields |
| 34 | Connector |
| 40 | Cable Entry Gland |
| 43 | Seal (Between Terminal Box and Frame) |
| 64 | Lifting Ring |
| 65 | Bearing Holder Outer End-Shields |
| 66 | Bearing Holder Inner End-Shields |
| 69 | Mounting foot (for motors with HT name structure.) |
| 69a | Alignment Bushing |
| 72b | Helical Spring |
| 75 | Oil Retaining Disc |
| 76 | Outer Snap Ring; For fixing the bearing and oil holding disc |
| 79 | Lubrication Nipples (Located on the front and rear sides of the motor) |
| 79a | Grease Pipe Holder |
| 79b | Grease Line Spacer |
| 81 | Oil Seal |

3 Phase, 400 V, 50 Hz, IE3-IE4



Duty Type
S1 (Continuous Operation)



Protection Class
IP 65



Insulation Class
H (180° C)



Temperature Rise
B (80 K)



Rated Power	Type	Efficiency Class	At Rated Power							At Start-Up				Tilting Moment Ratio	Moment of Inertia	Approx. Weight
			Speed	Current	Torque	Power Coefficient	Efficiency η			Current Ratio		Torque Ratio				
kW			RPM	A	Nm	Cos ϕ	4/4	3/4	1/2	Direct	Y/ Δ	Direct	Y/ Δ			

4 poles - 1500 PRM

110	KM4E 315 S 4a Ø85	IE4	1485	194	707,8	0,85	96,3	96,2	96	7,9	2,6	2,2	0,7	3,5	1,94	880
110	KM3E 315 S 4a Ø85	IE3	1485	199,0	707,8	0,84	95,40	95,20	95,00	7,4	2,5	2,2	0,7	3,4	1,67	876
132	KM4E 315 M 4b Ø85	IE4	1485	227	849,5	0,87	96,4	96,7	96,4	8,7	2,9	2,6	0,9	3,7	2,47	1034
132	KM3E 315 M 4b Ø85	IE3	1485	232,00	850,0	0,86	95,60	95,40	95,30	8,2	2,7	2,5	0,8	3,5	2	1032
160	KM4E 315 L 4c Ø85	IE4	1490	275	1026	0,87	96,6	96,7	96,4	8,6	2,9	2,3	0,8	3,5	3,08	1110
160	KM3E 315 L 4c Ø85	IE3	1485	277,00	1027,0	0,87	95,80	95,60	95,60	7,3	2,4	2,0	0,7	3,0	2,34	1098
185	KM4E 315 L 4d Ø85	IE4	1490	318,00	1189,0	0,87	96,70	96,70	96,40	9,0	3,0	2,6	0,9	3,8	3,21	1146
185	KMM3E 315 L 4d Ø85	IE3	1485	324,00	1190,5	0,86	96,00	96,00	95,80	8,1	2,7	2,4	0,8	3,5	2,54	1112
200	KMM4E 315 L 4e Ø85	IE4	1490	344,00	1282,0	0,87	96,70	96,93	96,74	8,5	2,8	2,6	0,9	3,6	3,65	1268
200	KMM3E 315 L 4e Ø85	IE3	1485	350,00	1284,0	0,86	96,00	95,80	95,80	7,8	2,6	2,5	0,8	3,3	2,81	1200
250	KM4E 315 HT 4f Ø100	IE4	1490	425,0	1595,0	0,88	96,7	96,6	96,1	9,0	3,0	2,6	0,9	3,7	4,2	1415
250	KM3E 315 HT 4f Ø100	IE3	1485	423,0	1596,0	0,89	96,00	95,80	95,80	8,0	2,7	2,2	0,7	3,3	3,88	1300
250	KM4E 355 M 4a Ø100	IE4	1490	456	1602,2	0,82	96,7	96,7	96,2	8,7	2,9	3	1,0	3,7	6	1400
250	KMM3E 355 M 4a Ø100	IE3	1490	430,00	1602,3	0,87	96,00	96,00	96,00	7,2	2,4	2,2	0,7	3,0	5,5	1378
315	KM4E 355 M 4b Ø100	IE4	1490	581	2018,8	0,81	96,7	96,7	96,2	8,0	2,7	2,9	1,0	3,6	6,5	1438
315	KMM3E 355 M 4b Ø100	IE3	1490	540,00	2019,0	0,88	96,00	96,00	95,90	7,2	2,4	2,2	0,7	3,0	6,0	1400
355	KMM3E 355 L 4c Ø100	IE3	1490	610,00	2275,3	0,87	96,00	96,00	96,10	7,2	2,4	2,2	0,7	3,0	7,9	1720
400	KMM3E 355 L 4d Ø100	IE3	1490	690	2563,8	0,87	96,00	96,1	96,99	7,2	2,4	2,2	0,7	3,0	7,9	1720

6 poles - 750 RPM

132	KM3E 315 L 6d Ø85	IE3	990	244	1272,5	0,82	95,4	95,8	95,6	7	2,3	2	0,7	2,8	3,89	1040
160	KM3E 315 L 6e Ø85	IE3	990	291,1	1544,5	0,83	95,6	95,9	95,8	7,5	2,5	2,3	0,8	3,0	4,14	1100
132	KM4E 315 L 6d Ø85	IE4	990	240,00	1271,8	0,83	96,00	96,24	96,00	7,1	2,4	2,0	0,7	2,8	3,69	1120
160	KM4E 315 L 6e Ø85	IE4	990	289,3	1543,4	0,83	96,2	96,2	96	7,7	2,6	2,3	0,8	3,1	4,5	1200
185	KM4E 355 M 6f Ø100	IE4	995	330,3	1775,5	0,84	96,27	96,27	95,3	7,5	2,5	2,2	0,7	3,1	7,8	1390
200	KM4E 355 M 6b Ø100	IE4	995	361,0	1919,5	0,83	96,3	96,3	95,7	7,7	2,6	2,2	0,7	3,2	8,3	1495

T : Detachable Feet
 Ø : Shaft Diameter

Efficiency values are calculated by the indirect measurement method in accordance with IEC 60034-2-1:2014. Additional losses are determined based on test results at variable load values.

CRUSHER MOTORS / MOTOR DIMENSIONS

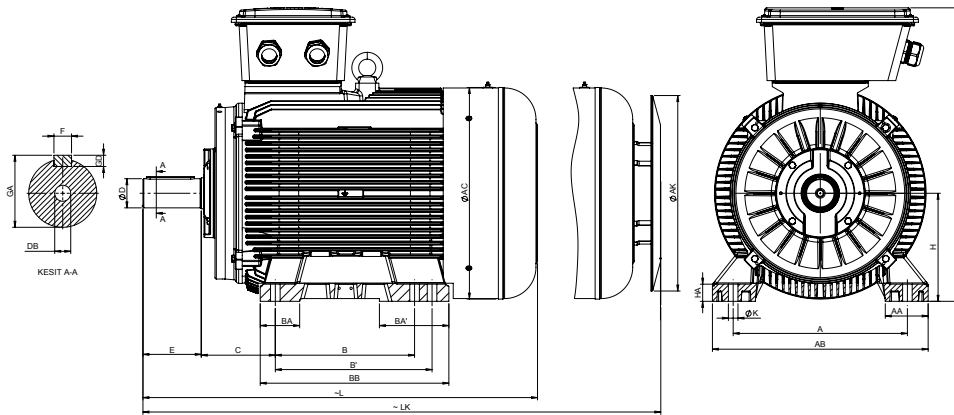

FOOT MOUNTED MOTOR - B3, B6, B7, B8, B15, V5, V6

Frame Size	Pole	H	HD	HA	A	AA	ACØ	AKØ	KØ	B	B'	BA	BA'	BB	L	LK	C	E	DB	DØ	GA	FxGD
315	M	4-6	315	50	508	125	617	571	28	406	457	115	203	550	1165	1242	216	170	M20	85	90	22x14
	L									-	125	-	600	1236	1313							
	HT/H									-	-	-	600	1355	1432							
315*	HT/H		865							-	150	-		1395*	1472*	228	210*	M24*	100*	106*	28x16*	
355	M		355	990	610	150	735			560	-	156	-	680	1384	1461	254	210	M24	100	106	28x16

*These dimensions are valid for 250 kW, 315-frame crusher motors.

*Upon request, 315 frame motors within the 110-200 kW power range can be manufactured with a ØD diameter of Ø100 mm.

SMOKE EXTRACTION MOTORS

Special
Series

A photograph of a tunnel interior, showing light trails from vehicles and a green emergency light on the wall. The image is partially obscured by a dark blue diagonal shape that contains the text.



CERTIFICATED

SMOKE EXTRACTION MOTORS

Smoke Extraction Motors have been certified as a result of tests performed in accordance with TS EN 12101-3 standard. The tests were carried out in Applus+ and Efectis Test Laboratory. As a result of the tests, Gamak Smoke Extraction Motors were certified according to 300°C 2 hours and F400°C operation. They are used to create a smoke-free area so that extinguishing and rescue operations can be carried out easily in case of fire and so that the living beings in the environment are not affected. Smoke Extraction motors work in conjunction with jet fans both in emergency situations in case of fire and for ventilation needs in closed environments. They are designed for S1 Continuous + S2 Short-term (Emergency) operation.

Smoke Extraction Motors Features	
Power Range	0,75-90 kW
Pole	2-4-6 / Double Speed
Efficiency	IE3
Frame	80-280
Frame Material	Cast Iron
Protection Class	IP55
Insulation Class	H
Cooling Method	IC 418 (TEAO-Totally Enclosed Air Over) (Fully closed system cooled by external air flow)
Installation Arrangement	B3/B5/B35/B14/B14-2/B34/B34-2/B30 (Pad Mounted)

There are 2 types of motors used in these ventilators:

S2 : Short-term EMERGENCY operation - Operation at a predetermined time and temperature in case of fire.

S1 + S2 : Continuous operation + short-term EMERGENCY operation - Continuous operation is for ventilation purposes, e.g. exhaust gas evacuation in highway tunnels.

Smoke motors can be manufactured with high efficiency if required for continuous operation. The duration and the temperature at which the motors will be operated in EMERGENCY operation must be specified in advance by the user. In the TS EN 12101-3 standards, a classification is made according to the temperature values and operating times in the table below.

Classification	Temperature (°C)	Shortest working time (minute)
F200	200	120
F300	300	60*
F400	400	120

For example, engines in the F300 class are manufactured to operate at 300°C for 1 hour. Accordingly, Smoke Extraction motors suitable for operation at different temperatures and durations are manufactured.

*GAMAK F300 smoke extraction motors are manufactured to operate continuously at 300°C for 2 hours.

NOTE: The motor used once in emergency operation must be replaced. The features of standard smoke motors also End-Shields Pad Mounted motors.



SMOKE EXTRACTION MOTORS / SPARE PARTS

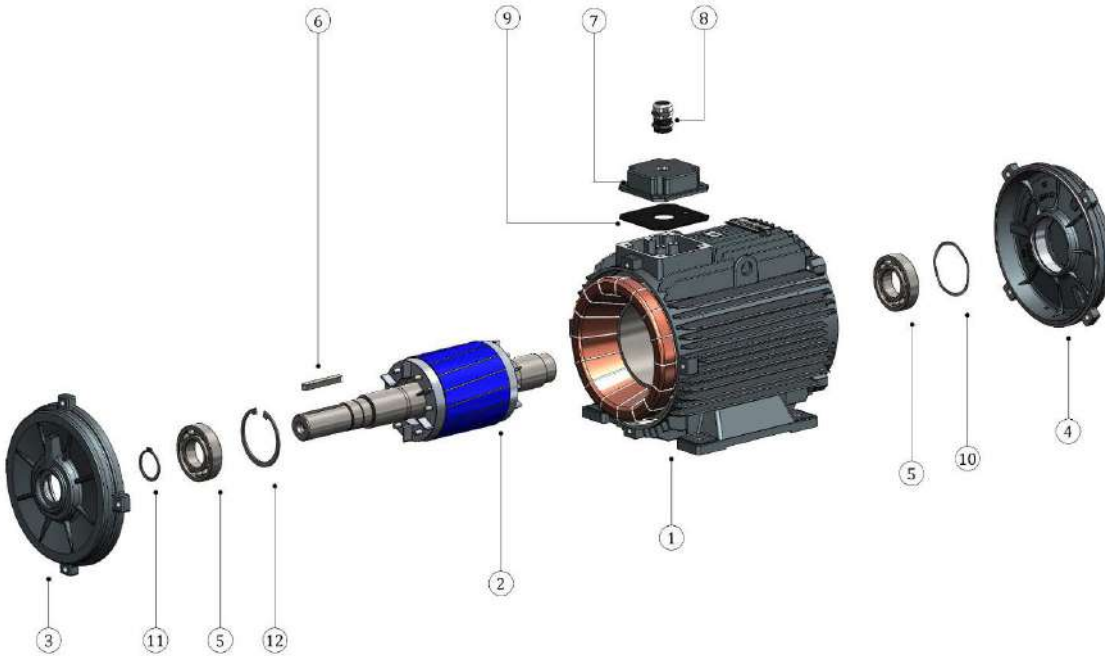

- | | |
|----|--|
| 1 | Stator with Complete Windings: Varnished and installed to the body |
| 2 | Complete Rotor: With balanced, shaft, machined (excluding keys) |
| 3 | Front End-Shields |
| 4 | Rear End-Shields |
| 5 | Bearing |
| 6 | Shaft end Wedge |
| 7 | Terminal End-Shields |
| 8 | Cable Entry Gland |
| 9 | Cable Protection |
| 10 | Terminal Box End-Shields Seal |
| 11 | Disc Spring |
| 12 | Outer Ring |
| 13 | Inner Ring |

PAD MOUNTED SMOKE EXTRACTION MOTORS / SPARE PARTS

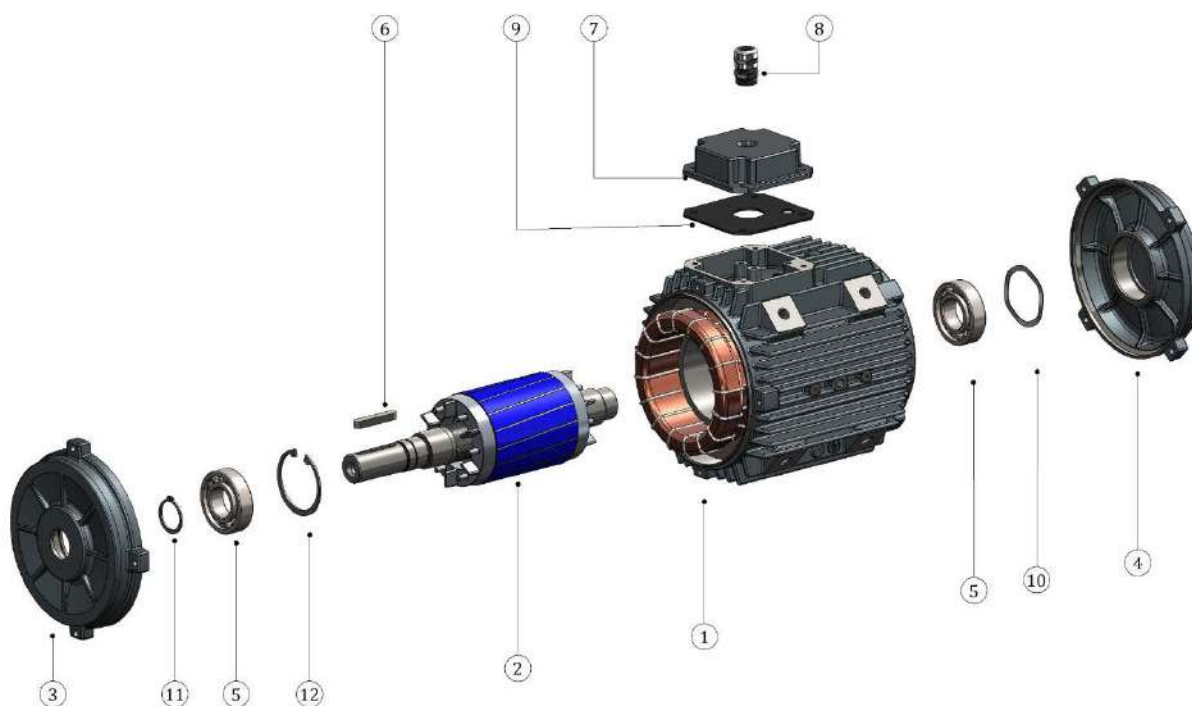

- | | |
|----|--|
| 1 | Stator with Complete Windings: Varnished and installed to the body |
| 2 | Complete Rotor: With balanced, shaft, machined (excluding keys) |
| 3 | Front End-Shields |
| 4 | Rear End-Shields |
| 5 | Bearing |
| 6 | Shaft end Wedge |
| 7 | Terminal End-Shields |
| 8 | Cable Entry Gland |
| 9 | Cable Protection |
| 10 | Terminal Box End-Shields Seal |
| 11 | Disc Spring |
| 12 | Outer Ring |
| 13 | Inner Ring |

3 Phase, 400 V, 50 Hz, IE3, F300



Duty Type
S1 (Continuous Operation)



Insulation Class
H (180°)



Protection Class
IP 55



Temperature Rise
B (80 K)



Rated Power	Type	At Rated Power							At Starting				Breakdown Torque Ratio	Moment of Inertia	Approx. Weight
		Speed	Current	Torque	Power Coefficient	Efficiency η			Current Ratio		Torque Ratio				
		RPM	A	Nm	Cos ϕ	4/4	3/4	1/2	Direct	Y/ Δ	Direct	Y/ Δ			

2 poles - 3000 RPM

0,75	GM3F3 80 M 2a	2860	1,6	2,5	0,84	80,7	80,7	80,4	5,7	-	2,4	-	3	0,00050	9,0
1,1	GM3F3 80 M 2b	2865	2,3	3,7	0,83	82,7	82,7	82,1	5,9	-	2,8	-	3,4	0,00050	9,0
1,5	GM3F3 90 S 2a	2895	3,1	4,9	0,83	84,2	84,2	83,0	6,5	-	2,4	-	3,2	0,0034	12,1
2,2	GM3F3 90 L 2b	2905	4,6	7,2	0,80	85,9	85,8	84,9	7,5	-	3,2	-	3,6	0,004	13,8
3	GM3F3 100 L 2a	2900	5,80	9,9	0,86	87,1	86,9	85,3	7,6	-	3,4	-	4	0,0031	22
4	GM3F3 112 M 2a	2920	7,40	13,1	0,89	88,1	88,0	87,2	7,2	2,3	2,8	0,9	3,5	0,0048	24,1
5,5	GM3F3 132 S 2a	2925	10,2	18	0,87	89,2	89,0	87,4	7,2	2,3	2,1	0,7	3	0,015	51
7,5	GM3F3 132 M 2b	2925	13,5	24,5	0,93	90,1	90,1	89,5	7,6	2,5	2,6	0,85	3,3	0,021	63
11	GM3F3 160 M 2a	2950	19,8	35,7	0,92	91,2	91,2	90,4	7,2	2,3	2,2	0,6	3	0,031	90
15	GM3F3 160 M 2b	2955	25,7	48,5	0,92	91,9	91,8	91,2	7,9	2,5	2,2	0,7	2,9	0,041	105
18,5	GM3F3 160 L 2c	2960	31,4	59,7	0,92	92,4	92,5	92,0	8,1	2,6	2,2	0,7	3,1	0,049	122
22	GM3F3 180 M 2a	2960	36,9	71	0,93	92,7	92,6	92,2	8,5	2,7	2,9	0,9	3,4	0,091	157
30	GM3F3 200 L 2a	2980	52,0	96,1	0,89	93,3	93,3	92,8	8,5	2,7	2,8	0,9	3,5	0,15	161
37	GM3F3 200 L 2b	2980	63,0	118,6	0,90	93,7	93,7	93,1	8,3	2,7	2,8	0,9	3,1	0,17	191
45	GM3F3 225 M 2a	2980	77,0	144,2	0,90	94,0	94,1	93,0	8,7	2,8	2,7	0,9	3,1	0,26	400
55	GM3F3 250 M 2a	2985	92,0	176,0	0,92	94,30	94,50	93,30	8,7	2,9	2,9	1,0	3,0	0,41	445
75	GM3F3 280 S 2a	2985	127	239,9	0,90	94,70	94,60	94,00	8,0	2,7	2,9	1,0	3,2	0,62	585
90	GM3F3 280 M 2b	2985	148	287,9	0,92	95,00	95,00	93,70	8,2	2,7	2,9	1,0	3,0	0,74	645

4 poles - 1500 RPM

0,75	GM3F3 80 M 4b	1450	2	5,0	0,66	82,5	82,4	81,5	5,6	-	3,0	-	3,5	0,0021	13
0,55	GM3F3 80 M 4a	1430	1,5	3,6	0,66	80,8	80,7	79,8	5,0	-	2,5	-	3	0,0025	10,0
1,1	GM3F3 90 S 4a	1450	2,5	7,2	0,76	84,1	84,0	83,1	6,1	-	2,7	-	3,5	0,0033	12,2
1,5	GM3F3 90 L 4b	1450	3,5	9,9	0,75	85,3	85,3	84,3	6,3	-	2,9	-	3,6	0,0041	14,0
2,2	GM3F3 100 L 4a	1445	4,7	14,5	0,78	86,7	86,8	85,0	5,9	-	2,7	-	3,3	0,0052	26,3
3	GM3F3 100 H 4b	1445	6,60	19,8	0,75	87,7	87,8	86,1	6,7	-	2,5	-	3,4	0,0068	29,2
4	GM3F3 112 H 4a	1450	8,00	26,3	0,81	88,6	88,5	88,0	7	2,4	2,8	0,95	3,45	0,012	36
5,5	GM3F3 132 S 4a	1450	11,0	36,2	0,81	89,6	89,6	88,8	6	2	2,4	0,9	3	0,026	38,4
7,5	GM3F3 132 M 4b	1450	15,1	49,3	0,8	90,4	90,5	89,6	5,9	2	2,5	0,9	2,80	0,032	49,3
11	GM3F3 160 M 4a	1470	21,1	71,5	0,82	91,4	91,3	91,0	6,1	2	1,9	0,6	2,6	0,076	92
15	GM3F3 160 L 4b	1475	29,7	97,1	0,79	92,1	92,0	91,8	7,5	2,5	2,5	0,85	3,3	0,0102	115
18,5	GM3F3 180 M 4a	1475	34,0	119,8	0,85	92,6	92,6	91,6	8,5	2,7	2,9	0,95	3,9	0,177	160
22	GM3F3 180 L 4b	1475	39,4	142,4	0,87	93,0	92,8	92,0	7,5	2,4	2,9	1	3,5	0,192	215
30	GM3F3 200 L 4a	1475	52,8	194,2	0,88	93,6	93,5	93,0	8,2	2,6	2,4	0,8	3	0,264	225
37	GM3F3 225 S 4a	1475	67,0	239,6	0,85	93,9	93,9	93,5	7,5	2,4	3,1	1	3,3	0,36	350
45	GM3F3 225 M 4b	1475	80,0	291,4	0,86	94,2	94,2	93,4	7,4	2,4	3	1	3,1	0,44	380
55	GM3F3 250 M 4a	1480	96,0	354,9	0,87	94,60	94,70	94,00	7,7	2,6	3,2	1,1	3,0	0,72	420
75	GM3F3 280 S 4a	1485	133	482,3	0,86	95,00	94,90	94,40	7,6	2,5	2,9	1,0	1,0	0,96	550
90	GM3F3 280 M 4b	1485	158	578,8	0,86	95,20	95,20	94,80	7,4	2,5	2,9	1,0	3,0	1,32	665

All motors are cast iron. Efficiency Values are calculated by indirect measurement method in accordance with IEC 60034-2-1:2014 standard. Additional losses are determined based on test results at varying load ratings.

3 Phase, 400 V, 50 Hz, IE3, F300

Duty Type
S1 (Continuous Operation)

Protection Class
IP 55

Insulation Class
H (180°)

Temperature Rise
B (80 K)



F400 smoke extraction motors are designed in accordance with the relevant standards, and the official certification process is currently ongoing.

Rated Power	Type	At Rated Power							At Start-up				Tilting Moment Ratio	Moment of Inertia	Approx. Weight
		Speed	Current	Torque	Power Coefficient	Efficiency η			Current Ratio		Torque Ratio				
		RPM	A	Nm	Cos ϕ	4/4	3/4	1/2	Direct	Y/ Δ	Direct	Y/ Δ			

2 poles - 3000 RPM

0,75	GM3F4 80 M 2a	2860	1,6	2,5	0,84	80,7	80,7	80,4	5,7	-	2,4	-	3	0,00050	9,0
1,1	GM3F4 80 M 2b	2865	2,3	3,7	0,83	82,7	82,7	82,1	5,9	-	2,8	-	3,4	0,00050	9,0
1,5	GM3F4 90 S 2a	2895	3,1	4,9	0,83	84,2	84,2	83,0	6,5	-	2,4	-	3,2	0,0034	12,1
2,2	GM3F4 90 L 2b	2905	4,6	7,2	0,80	85,9	85,8	84,9	7,5	-	3,2	-	3,6	0,004	13,8
3	GM3F4 100 L 2a	2900	5,80	9,9	0,86	87,1	86,9	85,3	7,6	-	3,4	-	4	0,0031	22
4	GM3F4 112 M 2a	2920	7,40	13,1	0,89	88,1	88,0	87,2	7,2	2,3	2,8	0,9	3,5	0,0048	24,1
5,5	GM3F4 132 S 2a	2925	10,2	18	0,87	89,2	89,0	87,4	7,2	2,3	2,1	0,7	3	0,015	66,5
7,5	GM3F4 132 M 2b	2925	13,5	24,5	0,93	90,1	90,1	89,5	7,6	2,5	2,6	0,85	3,3	0,021	80,4
11	GM3F4 160 M 2a	2950	19,8	35,7	0,92	91,2	91,2	90,4	7,2	2,3	2,2	0,6	3	0,031	113
15	GM3F4 160 M 2b	2955	25,7	48,5	0,92	91,9	91,8	91,2	7,9	2,5	2,2	0,7	2,9	0,041	128
18,5	GM3F4 160 L 2c	2960	31,4	59,7	0,92	92,4	92,5	92,0	8,1	2,6	2,2	0,7	3,1	0,049	145
22	GM3F4 180 M 2a	2960	36,9	71	0,93	92,7	92,6	92,2	8,5	2,7	2,9	0,9	3,4	0,091	193
30	GM3F4 200 L 2a	2980	52,0	96,1	0,89	93,3	93,3	92,8	8,5	2,7	2,9	0,9	3,5	0,15	210
37	GM3F4 200 L 2b	2980	63,0	118,6	0,90	93,7	93,7	93,1	8,3	2,7	2,8	0,9	3,1	0,17	240
45	GM3F4 225 M 2a	2980	77,0	144,2	0,90	94,0	94,1	93,0	8,7	2,8	2,7	0,9	3,1	0,26	400
55	GM3F4 250 M 2a	2985	92,0	176,0	0,92	94,30	94,50	93,30	8,7	2,9	2,9	1,0	3,0	0,41	445
75	GM3F4 280 S 2a	2985	127	239,9	0,90	94,70	94,60	94,00	8,0	2,7	2,9	1,0	3,2	0,62	585
90	GM3F4 280 M 2b	2985	148	287,9	0,92	95,00	95,00	93,70	8,2	2,7	2,9	1,0	3,0	0,74	645

4 poles - 1500 RPM

0,75	GM3F4 80 M 4b	1450	2	5,0	0,66	82,5	82,4	81,5	5,6	-	3,0	-	3,5	0,0021	13
0,55	GM3F4 80 M 4a	1430	1,5	3,6	0,66	80,8	80,7	79,8	5,0	-	2,5	-	3	0,0025	10,0
1,1	GM3F4 90 S 4a	1450	2,5	7,2	0,76	84,1	84,0	83,1	6,1	-	2,7	-	3,5	0,0033	12,2
1,5	GM3F4 90 L 4b	1450	3,5	9,9	0,75	85,3	85,3	84,3	6,3	-	2,9	-	3,6	0,0041	14,0
2,2	GM3F4 100 L 4a	1445	4,7	14,5	0,78	86,7	86,8	85,0	5,9	-	2,7	-	3,3	0,0052	26,3
3	GM3F4 100 H 4b	1445	6,60	19,8	0,75	87,7	87,8	86,1	6,7	-	2,5	-	3,4	0,0068	29,2
4	GM3F4 112 H 4a	1450	8,00	26,3	0,81	88,6	88,5	88,0	7	2,4	2,8	0,95	3,45	0,012	36
5,5	GM3F4 132 S 4a	1450	11,0	36,2	0,81	89,6	89,6	88,8	6	2	2,4	0,9	3	0,026	48
7,5	GM3F4 132 M 4b	1450	15,1	49,3	0,8	90,4	90,5	89,6	5,9	2	2,5	0,9	2,80	0,032	56
11	GM3F4 160 M 4a	1470	21,1	71,5	0,82	91,4	91,3	91,0	6,1	2	1,9	0,6	2,6	0,076	124
15	GM3F4 160 L 4b	1475	29,7	97,1	0,79	92,1	92,0	91,8	7,5	2,5	2,5	0,85	3,3	0,102	151
18,5	GM3F4 180 M 4a	1475	34,0	119,8	0,85	92,6	92,6	91,6	8,5	2,7	2,9	0,95	3,9	0,177	194
22	GM3F4 180 L 4b	1475	39,4	142,4	0,87	93,0	92,8	92,0	7,5	2,4	2,9	1	3,5	0,192	215
30	GM3F4 200 L 4a	1475	52,8	194,2	0,88	93,6	93,5	93,0	8,2	2,6	2,4	0,8	3	0,264	273
37	GM3F4 225 S 4a	1475	67,0	239,6	0,85	93,9	93,9	93,5	7,5	2,4	3,1	1	3,3	0,36	350
45	GM3F4 225 M 4b	1475	80,0	291,4	0,86	94,2	94,2	93,4	7,4	2,4	3	1	3,1	0,44	380
55	GM3F4 250 M 4a	1480	96,0	354,9	0,87	94,60	94,70	94,00	7,7	2,6	3,2	1,1	3,0	0,72	420
75	GM3F4 280 S 4a	1485	133	482,3	0,86	95,00	94,90	94,40	7,6	2,5	2,9	1,0	1,0	0,96	550
90	GM3F4 280 M 4b	1485	158	578,8	0,86	95,20	95,20	94,80	7,4	2,5	2,9	1,0	3,0	1,32	665

All motors are cast iron. Efficiency Values are calculated by indirect measurement method in accordance with IEC 60034-2-1:2014 standard. Additional losses are determined based on test results at varying load ratings.

3 Phase, 400 V, 50 Hz, IE3, PAD MOUNTED, F300



Duty Type
S1 (Continuous Operation)



Protection Class
IP 55



Insulation Class
H (180°)



Temperature Rise
B (80 K)



Rated Power	Type	At Rated Power							At Starting				Breakdown Torque Ratio	Moment of Inertia	Approx. Weight
		Speed	Current	Torque	Power Coefficient	Efficiency η			Current Ratio		Torque Ratio				
kW		RPM	A	Nm	Cos ϕ	4/4	3/4	1/2	Direct	Y/ Δ	Direct	Y/ Δ			
2 poles - 3000 RPM															
0,75	GM3P3 80 M 2a	2860	1,6	2,5	0,84	80,7	80,7	80,4	5,7	-	2,4	-	3	0,00050	9,0
1,1	GM3P3 80 M 2b	2865	2,3	3,7	0,83	82,7	82,7	82,1	5,9	-	2,8	-	3,4	0,00050	9,0
1,5	GM3P3 90 S 2a	2895	3,1	4,9	0,83	84,2	84,2	83,0	6,5	-	2,4	-	3,2	0,0034	12,1
2,2	GM3P3 90 L 2b	2905	4,6	7,2	0,80	85,9	85,8	84,9	7,5	-	3,2	-	3,6	0,004	13,8
3	GM3P3 100 L 2a	2900	5,80	9,9	0,86	87,1	86,9	85,3	7,6	-	3,4	-	4	0,0031	22
4 poles - 1500 RPM															
0,75	GM3P3 80 M 4b	1450	2	5,0	0,66	82,5	82,4	81,5	5,6	-	3,0	-	3,5	0,0021	13
0,55	GM3P3 80 M 4a	1430	1,5	3,6	0,66	80,8	80,7	79,8	5,0	1,7	2,5	0,8	3	0,0025	10,0
1,1	GM3P3 90 S 4a	1450	2,5	7,2	0,76	84,1	84,0	83,1	6,1	-	2,7	-	3,5	0,0033	12,2
1,5	GM3P3 90 L 4b	1450	3,5	9,9	0,75	85,3	85,3	84,3	6,3	-	2,9	-	3,6	0,0041	14,0
2,2	GM3P3 100 L 4a	1445	5,00	14,5	0,73	86,7	86,8	85,0	5,9	-	2,7	-	3,4	0,0052	26,3
3	GM3P3 100 H 4b	1445	6,60	19,8	0,75	87,7	87,8	86,1	6,4	-	3,2	-	3,8	0,0068	29,2

All motors are cast iron. Efficiency Values are calculated by indirect measurement method in accordance with IEC 60034-2-1:2014 standard. Additional losses are determined based on test results at varying load ratings.

3 Phase, 400 V, 50 Hz, IE3, PAD MOUNTED, F400



Duty Type
S1 (Continuous Operation)



Protection Class
IP 55



Insulation Class
H (180°)



Temperature Rise
B (80 K)



F400 smoke extraction motors are designed in accordance with the relevant standards, and the official certification process is currently ongoing.

Rated Power	Type	At Rated Power							At Starting				Breakdown Torque Ratio	Moment of Inertia	Approx. Weight	
		Speed	Current	Torque	Power Coefficient	Efficiency η			Current Ratio		Torque Ratio					
kW		RPM	A	Nm	Cos ϕ	4/4	3/4	1/2	Direct	Y/ Δ	Direct	Y/ Δ				
2 poles - 3000 RPM																
1,5	GM3P4 90 S 2a	2895	3,1	4,9	0,83	84,2	84,2	83,0	6,5	-	2,4	-	3,2	0,0034	12,1	
0,75	GM3P4 80 M 2a	2860	1,6	2,5	0,84	80,7	80,7	80,4	5,7	-	2,4	-	3	0,00050	9,0	
1,1	GM3P4 80 M 2b	2865	2,3	3,7	0,83	82,7	82,7	82,1	5,9	-	2,8	-	3,4	0,00050	9,0	
2,2	GM3P4 90 L 2b	2905	4,6	7,2	0,80	85,9	85,8	84,9	7,5	-	3,2	-	3,6	0,004	13,8	
3	GM3P4 100 L 2a	2900	5,80	9,9	0,86	87,1	86,9	85,3	7,6	-	3,4	-	4	0,0031	22	
4 poles - 1500 RPM																
1,1	GM3P4 90 S 4a	1450	2,5	7,2	0,76	84,1	84,0	83,1	6,1	-	2,7	-	3,5	0,0033	12,2	
0,55	GM3P4 80 M 4a	1430	1,5	3,6	0,66	80,8	80,7	79,8	5,0	1,7	2,5	0,8	3	0,0025	10,0	
0,75	GM3P4 80 M 4b	1450	2	5,0	0,66	82,5	82,4	81,5	5,6	-	3,0	-	3,5	0,0021	13	
1,5	GM3P4 90 L 4b	1450	3,5	9,9	0,75	85,3	85,3	84,3	6,3	-	2,9	-	3,6	0,004	13,8	
2,2	GM3P4 100 L 4a	1445	5,00	14,5	0,73	86,7	86,8	85,0	5,9	-	2,7	-	3,4	0,0052	26,3	
3	GM3P4 100 H 4b	1445	6,60	19,8	0,75	87,7	87,8	86,1	6,4	-	3,2	-	3,8	0,0068	29,2	

All motors are cast iron. Efficiency Values are calculated by indirect measurement method in accordance with IEC 60034-2-1:2014 standard. Additional losses are determined based on test results at varying load ratings.

3 Phase, 400 V, 50 Hz, IE3, DOUBLE SPEED, F300



Duty Type
S1 (Continuous Operation)



Insulation Class
H (180°)



Protection Class
IP 55



Temperature Rise
B (80 K)



Rated Power	Type	At Rated Power					At Starting		Breakdown Torque Ratio	Moment of Inertia	Approx. Weight
		Hiz	Current	Torque	Power Coefficient	Efficiency η	Current Ratio	Torque Ratio			
kW		RPM	A	Nm	Cos ϕ	4/4	Direct	Direct			

4/2 poles - 1500/3000 RPM

0,25	1	V.GMF3 80 M 4/2b	1420	2870	0,76	2,3	1,7	3,3	0,68	0,78	68,3	71,6	3,6	4,5	1,3	1,5	2	2,4	0,00050	9,0
0,33	1,3	V.GMF3 90 S 4/2a	1460	2920	1	3,2	2,2	4,25	0,61	0,71	75,6	78,3	4,8	5,8	2,1	1,5	2,9	3,3	0,0034	12
0,66	2,7	V.GMF3 100 L 4/2a	1455	2890	1,45	5,3	4,3	8,9	0,77	0,89	79,8	80,7	4,7	4	1,3	0,9	2,3	2,1	0,0057	25,8
0,9	3,6	V.GMF3 112 M 4/2a	1440	2870	2	7,3	6	12	0,83	0,89	76,1	78,3	5,5	6	1,8	2	2,6	2,5	0,0039	25,2
1,25	5	V.GM3F3 132 S 4/2a	1475	2945	2,75	9,8	8,1	16,2	0,71	0,79	84	84,5	6,8	7,5	2,6	1,85	3,5	3,75	0,021	38,4
0,25	1	V.GMF3P 80 M 4/2b	1420	2870	0,76	2,3	1,7	3,3	0,68	0,78	68,3	71,6	3,6	4,5	1,3	1,5	2	2,4	0,00050	9,0
0,33	1,3	V.GMF3P 90 S 4/2a	1460	2920	1	3,2	2,2	4,25	0,61	0,71	75,6	78,3	4,8	5,8	2,1	1,5	2,9	3,3	0,0033	12,2
0,66	2,7	V.GMF3P 100 L 4/2a	1455	2890	1,45	5,3	4,3	8,9	0,77	0,89	79,8	80,7	4,7	4	1,3	0,9	2,3	2,1	0,0031	22

8/4 poles - 750/1500 RPM

0,25	1	V.GMF3 90 S 8/4a	710	1450	1	2,3	3,36	6,6	0,55	0,77	65,9	81,8	2,9	5,3	1,4	2	2,1	2,9	0,0034	12
0,33	1,4	V.GMF3 90 L 8/4b	710	1445	1,3	3,3	4,5	9,25	0,56	0,75	65,9	81,8	2,9	5,3	1,4	2	2,1	2,9	0,004	13,8
0,5	2	V.GMF3 100 L 8/4a	720	1450	1,9	5,1	6,7	13,2	0,56	0,73	66,7	77,9	3,1	4,5	1,3	1,6	2,2	2,7	0,0044	23,1
0,6	2,5	V.GMF3 100 L 8/4b	710	1445	2,1	5,4	8,1	16,5	0,57	0,8	72,9	83,8	3,1	5,5	1,5	1,9	2	2,9	0,0057	25,8
1	3,8	V.GMF3 112 M 8/4a	700	1425	3,2	8,3	14	25	0,63	0,83	70,2	78,3	3,4	5,2	1,4	2	2	2,5	0,0106	29,5
2,5	10	V.GM3F3 160 M 8/4a	730	1465	8,1	20,5	32,8	64,9	0,55	0,8	82,3	88,5	3,3	5,9	1,5	1,9	2	2,6	0,076	92
1,7	7	V.GM3F3 132 M 8/4b	730	1470	6,5	16,2	22,6	45,5	0,49	0,71	77,3	86,2	3,4	6,1	1,9	2,4	2,5	3,4	0,019	35
0,25	1	V.GMF3P 90 S 8/4a	710	1450	1	2,3	3,36	6,6	0,55	0,77	65,9	81,8	2,9	5,3	1,4	2	2,1	2,9	0,0034	12,1
0,33	1,4	V.GMF3P 90 L 8/4b	710	1445	1,3	3,3	4,5	9,25	0,56	0,75	65,9	81,8	2,9	5,3	1,4	2	2,1	2,9	0,0041	14,0
0,5	2	V.GMF3P 100 L 8/4a	720	1450	1,9	5,1	6,7	13,2	0,56	0,73	66,7	77,9	3,1	4,5	1,3	1,6	2,2	2,7	0,0052	26,3
0,6	2,5	V.GMF3P 100 L 8/4b	710	1445	2,1	5,4	8,1	16,5	0,57	0,8	72,9	83,8	3,1	5,5	1,5	1,9	2	2,9	0,0052	26,3

HIGH PERFORMANCE
IN THE MOST DIFFICULT CONDITIONS

GAMAK SMOKE EXTRACTION **MOTORS**

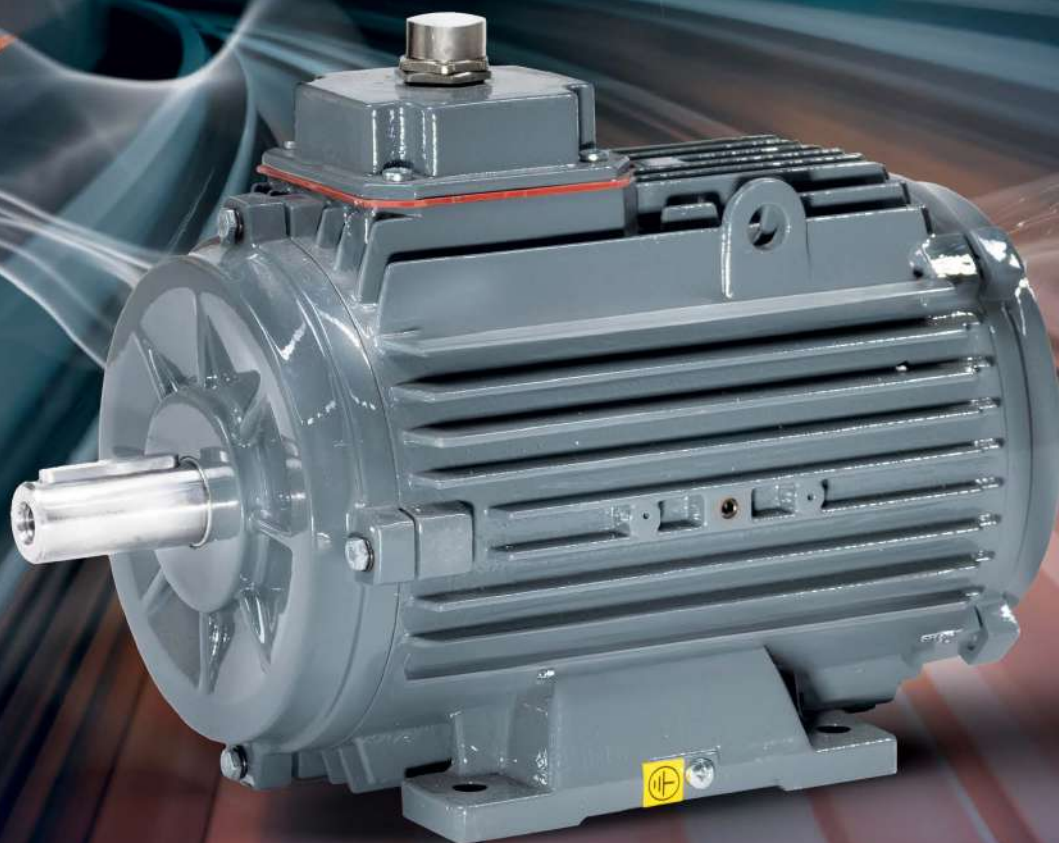

SMOKE EXTRACTION MOTORS / MOTOR DIMENSIONS

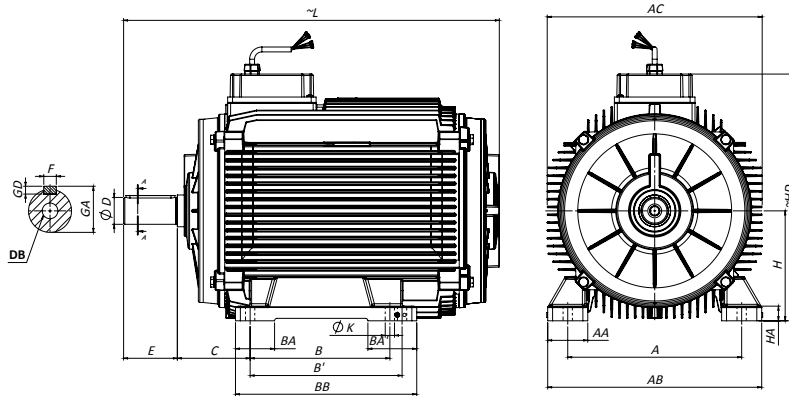

FOOT MOUNTED MOTOR (IEC 60072-1) - B3

Frame Size	H	HD	HA	A	AA	AB	ACØ	KØ	B	B'	BA	BA'	BB	L	C	E EA	DB	DØ	GA	FxGD
80 M	80	189	10	125	35	160	160	10	100	-	38	-	125	258	50	40	M6	19	21,5	6X6
90 S	90	209	12	140	40	180	180	10	100	-	40	-	130	270	56	50	M8	24	27	8X7
90 L	90	209	12	140	40	180	180	10	125	-	41	-	155	290	56	50	M8	24	27	8X7
100 L	100	234	13	160	40	200	198	12	140	-	45	-	170	323	63	60	M10	28	31	8X7
100 H	100	234	13	160	40	200	198	12	140	-	45	-	170	358	63	60	M10	28	31	8X7
112 M	112	252	14	140	190	230	208	12	140	-	38	-	170	341	70	60	M10	28	31	8X7
112 H	112	252	14	140	190	230	216	12	140	-	49	-	175	366	70	60	M10	28	31	8X7
132 S	132	300	15	216	50	260	262	12	140	-	50	-	180	413	89	80	M12	38	41	10X8
132 M	132	300	15	216	50	260	262	12	178	-	50	-	218	458	89	80	M12	38	41	10X8
160 M	160	374	22	254	63	312	313	15	210	254	75	-	305	557	108	110	M16	42	45	12X8
160 L	160	374	22	254	60	312	313	15	254	-	70	-	304	602	108	110	M16	42	45	12X8
180 M	180	414	24	279	74	354	350	15	241	-	60	-	291	613	121	110	M16	48	51,5	14X9
180 L	180	414	24	279	74	354	350	15	279	-	70	-	329	650	121	110	M16	48	51,5	14X9
200 L	200	465	26	318	81,5	398	390	19	305	-	72,5	-	355	742	133	110	M20	55	59	16X10
225 S (2 Pole)	225	505	30	356	82	438	440	19	286	311	80	100	365	666	149	110	M20	55	59	16x10
225 S (4 Pole)	225	505	30	356	82	438	440	19	286	311	80	100	365	696	149	140	M20	60	64	18x11
225 M (2 Pole)	225	505	30	356	82	438	440	19	286	311	80	100	371	759	149	110	M20	55	59	16X10
225 M (4 Pole)	225	505	30	356	82	438	440	19	286	311	75	100	371	789	149	140	M20	60	64	18x11
250 M (2 Pole)	250	505	35	406	80	484	479	24	349	-	85	-	410	815	168	140	M20	60	64	18X11
250 M (4 Pole)	250	505	35	406	80	484	479	24	349	-	85	-	410	815	168	140	M20	65	69	18X11
280 S (2 Pole)	280	564	40	457	120	550	543	24	368	419	-	-	474	873	190	140	M20	65	69	18X11
280 S (4 Pole)	280	564	40	457	120	550	543	24	368	419	-	-	474	873	190	140	M20	75	79,5	20x12
280 M (2 Pole)	280	564	40	457	120	550	543	24	368	419	-	-	474	873	190	140	M20	65	69	18X11
280 M (4 Pole)	280	564	40	457	120	550	543	24	368	419	-	-	474	873	190	140	M20	75	79,5	20x12

All dimensions are in mm

SMOKE EXTRACTION MOTORS / MOTOR DIMENSIONS

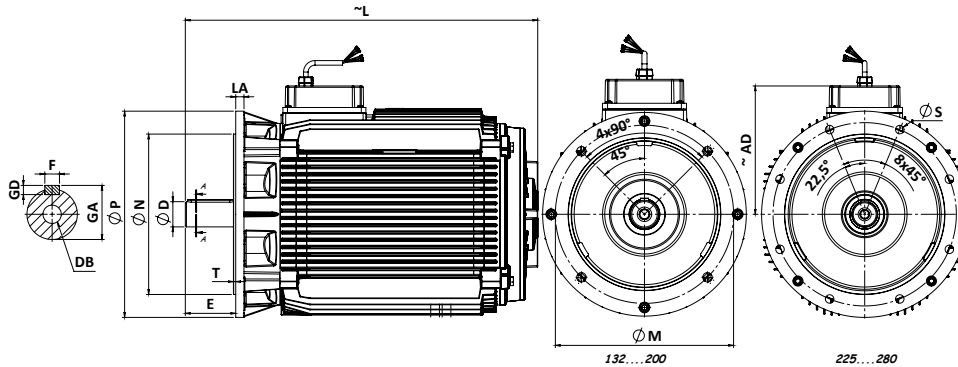

FLANGED MOTOR (FORM "A" - IEC 60072-1) - B5, V1, V3

Frame Size	Flange No	MØ	NØ	PØ	Fixing Hole		T	LA	AD	L	E EA	DB	DØ	GA	FxGD
					No.	SØ									
132 S	FF 265	265	230	300	4	14,5	4	18	168	413	80	M12	38	41	10X8
132 M	FF 265	265	230	300	4	14,5	4	18	168	458	80	M12	38	41	10X8
160 M	FF 300	300	250	350	4	18,5	5	18	214	557	110	M16	42	45	12X8
160 L	FF 300	300	250	350	4	18,5	5	18	214	602	110	M16	42	45	12X8
180 M	FT 300	300	250	350	4	18,5	5	18	234	613	110	M16	48	52	14X9
180 L	FT 300	300	250	350	4	18,5	5	18	234	650	110	M16	48	52	14X9
200 L	FF 350	350	300	400	4	18,5	5	18	265	742	110	M20	55	59	16X10
225 S (2 Pole)	FF 400	400	350	450	8	18,5	5	18	280	666	110	M20	55	59	16x10
225 S (4 Pole)	FF 400	400	350	450	8	18,5	5	18	280	696	140	M20	60	64	18x11
225 M (2 Pole)	FF 400	400	350	450	8	18,5	5	18	280	759	110	M20	55	59	16X10
225 M (4 Pole)	FF 400	400	350	450	8	18,5	5	18	280	789	140	M20	60	64	18x11
250 M (2 Pole)	FF 500	500	450	550	8	18,5	5	24	255,5	815	140	M20	60	64	18X11
250 M (4 Pole)	FF 500	500	450	550	8	18,5	5	24	255,5	815	140	M20	65	69	18X11
280 S (2 Pole)	FF 500	500	450	550	8	18,5	5	24	283,5	873	140	M20	65	69	18X11
280 S (4 Pole)	FF 500	500	450	550	8	18,5	5	24	283,5	873	140	M20	75	79,5	20x12
280 M (2 Pole)	FF 500	500	450	550	8	18,5	5	24	283,5	873	140	M20	65	69	18X11
280 M (4 Pole)	FF 500	500	450	550	8	18,5	5	24	283,5	873	140	M20	75	79,5	20x12

All dimensions are in mm.

SMOKE EXTRACTION MOTORS / MOTOR DIMENSIONS

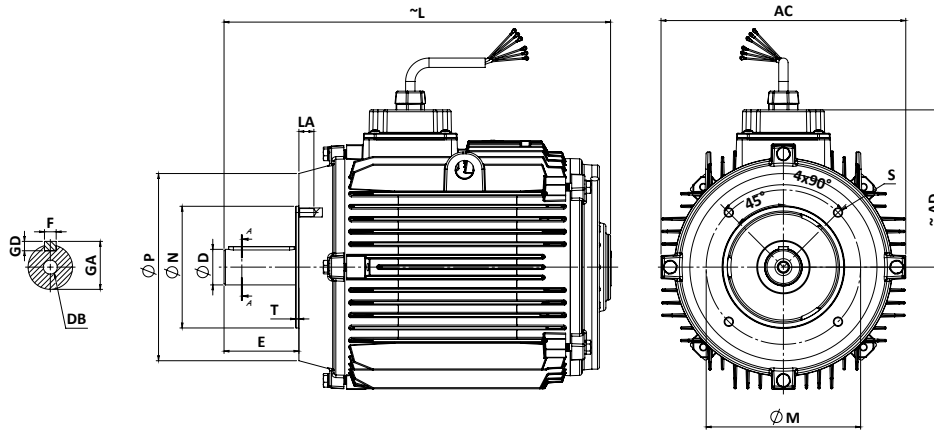

FLANGED MOTOR (FORM "C" - IEC 60072-1) - B14, V18, V19

Frame Size	Flange No	MØ	NØ	PØ	S	T	LA	ACØ	AKØ	AD	L	E EA	DB	DØ	G	FxGD
100 L	FF 130	130	110	160	M8	3,5	17	200	-	134	323	60	M10	28	31	8X7
100 H	FF 130	130	110	160	M8	3,5	17	200	-	134	358	60	M10	28	31	8X7
132 S	FF 165	165	130	200	M10	3,5	22	262	-	168	413	80	M12	38	41	10X8
132 M	FF 165	165	130	200	M10	3,5	22	262	-	168	458	80	M12	38	41	10X8
160 M	FT 215	215	180	250	M12	4	21	310	-	245	600	110	M16	42	45	12X8
160 L	FT 215	215	180	250	M12	4	21	310	-	245	644	110	M16	42	45	12X8

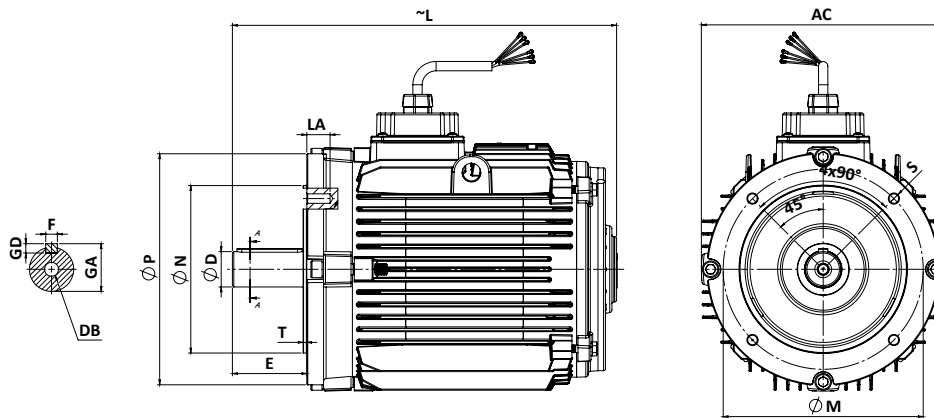

FLANGED MOTOR (FORM "C" - IEC 60072-1) - B14-2, V18, V19

Frame Size	Flange No	MØ	NØ	PØ	S	T	LA	ACØ	AKØ	AD	L	E EA	DB	DØ	GA	FxGD
132 S	FF 215	215	180	250	M12	4	25	262	-	168	413	80	M12	38	41	10X8
132 M	FF 215	215	180	248	M12	4	25	262	-	168	458	80	M12	38	41	10X8

All dimensions are in mm.

SMOKE EXTRACTION MOTORS / MOTOR DIMENSIONS

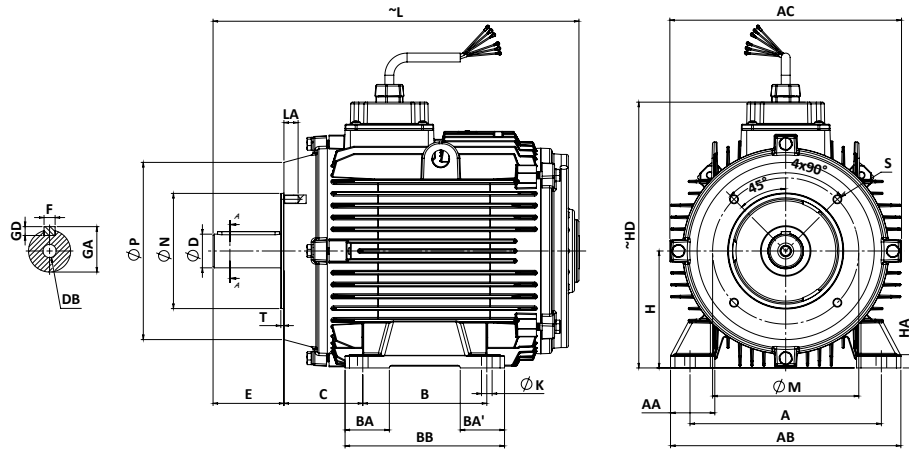
FOOT MOUNTED AND FLANGED MOTOR (FORM "C" - IEC 60072-1) - B34

Frame Size	H	HD	HA	A	AA	AB	ACØ	KØ	K1	B	B'	BA	BA'	BB	Flange No	MØ	NØ	PØ	SØ	T	LA	L	C	E EA	DB	DØ	GA	FxGD
100 L	100	234	13	160	40	200	200	12	12	140	-	45	-	170	FF 130	130	110	160	M8	3,5	17	323	63	60	M10	28	31	8X7
100 H	100	234	13	160	40	200	200	12	12	140	-	40	-	170	FF 130	130	110	160	M8	3,5	17	358	63	60	M10	28	31	8X7
132 S	132	300	15	216	50	260	262	12	-	140	-	50	-	180	FT 165	165	130	200	M10	3,5	22	413	89	80	M12	38	41	10X8
132 M	132	300	15	216	50	260	262	12	-	178	-	50	-	218	FT 165	165	130	200	M10	3,5	22	458	89	80	M12	38	41	10X8
160 M	160	400	22	254	60	312	310	15	-	210	254	62	-	305	FT 215	215	180	250	M12	4	21	600	108	110	M16	42	45	12X8
160 L	160	400	22	254	60	312	310	15	-	254	-	62	-	304	FT 215	215	180	250	M12	4	21	644	108	110	M16	42	45	12X8

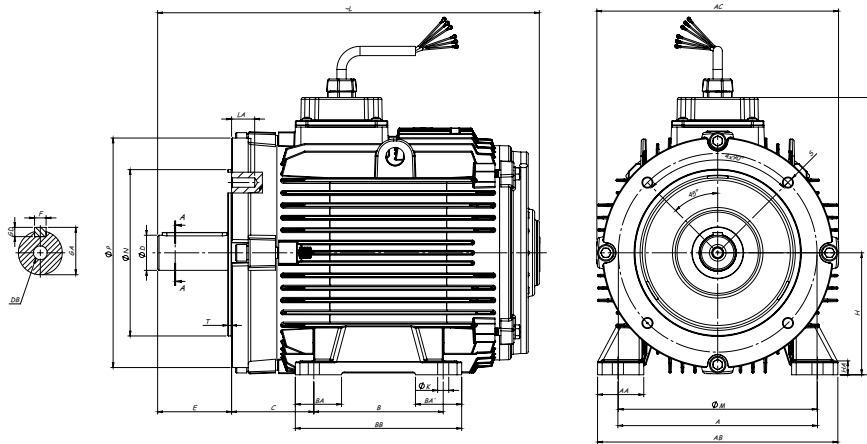

Frame Size	H	HD	HA	A	AA	AB	ACØ	KØ	K1	B	B'	BA	BA'	BB	Flange No	MØ	NØ	PØ	SØ	T	LA	L	C	E EA	DB	DØ	GA	FxGD
------------	---	----	----	---	----	----	-----	----	----	---	----	----	-----	----	-----------	----	----	----	----	---	----	---	---	------	----	----	----	------

FOOT MOUNTED AND FLANGED MOTOR (FORM "C" - IEC 60072-1) - B34-2

132 S	132	300	15	216	50	260	262	12	-	140	-	50	-	218	FT 215	215	180	250	M12	4	25	413	89	80	M12	38	41	10X8
132 M	132	300	15	216	50	260	262	12	-	178	-	50	-	218	FT 215	215	180	250	M12	4	25	458	89	80	M12	38	41	10X8

All dimensions are in mm

SMOKE EXTRACTION MOTORS / MOTOR DIMENSIONS

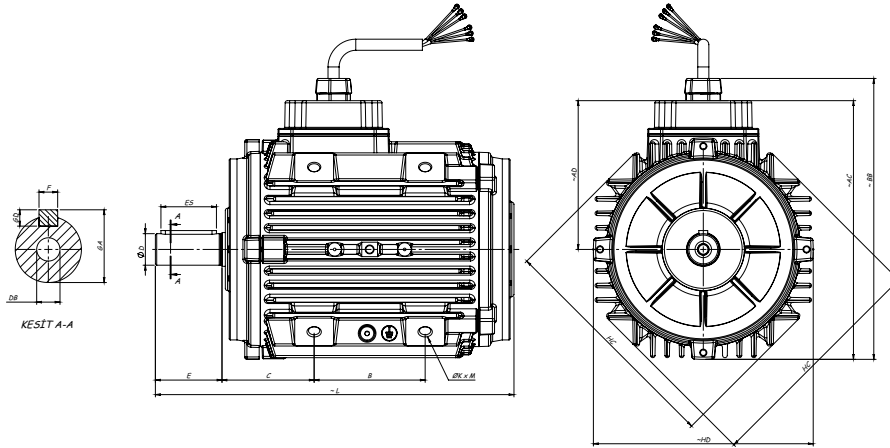

PAD MOUNTED SMOKE EXTRACTION MOTORS (FORM "C" - DIN EN 60072-1) - B30

Frame Size	H	AC	AD	B	BB	C	E	ϕD	ES	HC	HD	L	KxM
80	80	188	109	80	213	60	40	19	32	170	160	258	M12x1.5x15
90 S	90	208	119	65	233	73,5	50	24	40	190	180	270	M12x1.5x12
90 L	90	208	119	90	233	73,5	50	24	40	190	180	290	M12x1.5x12
100 L	100	233	134	100	260	83	60	28	50	210	198	323	M12x1.5x16

All dimensions are in mm.

MEDIUM VOLTAGE ELECTRIC MOTORS

Developed for
Trusted
Performance

Special
Series







Up To 4 MW

Medium Voltage Motors

GAMAK Medium Voltage Electric Motors are designed for industrial applications that require high power and efficiency. Our motors operate within a voltage range of 3.000 V to 10.000 V offering a wide power range between 150 kW and 4.000 kW.

Medium Voltage Electric Motor Features		
Voltage Range	3.000 – 10.000 V	 Operates reliably within 3.000 V to 10.000 V voltage range.
Power Range	150 – 4.000 kW	
Frame Size	355 – 1000	 IC411 and IC611 cooling systems provide effective thermal management, keeping the motor temperature under control.
Number of Pole	2, 4, 6, 8, 10, 12	
Mounting Type	B3, V1	
Degree of Protection	IP55, IP56, IP65	 IP55, IP56 and IP65 protection classes offer robust defense against dust and water ingress.
Frame Material	Cast Iron - Steel	
Cooling Type	IC411 – IC611	
Insulation Class	F (155 °C)	
Temperature Rise Class	B (80 K)	

Structure and Durability:

With a robust cast iron frame, these motors provide excellent durability under harsh operating conditions. The IP55, IP56 and IP65 protection ratings ensure effective resistance against dust and water ingress.

Performance Features:

Equipped with Class F insulation (up to 155 °C) and Class B temperature rise (80 K), the motors ensure long service life and reliable performance. Cooling types IC411 and IC611 enable efficient thermal management for continuous operation.

Installation and Flexibility:

Available with B3 and V1 mounting types, these motors can be easily integrated into various installation setups. Options with 2, 4, 6, 8, 10 and 12 poles provide optimal solutions for different speed and torque requirements.

Typical Applications

Medium voltage electric motors are widely used in industrial sectors where high power output and reliable operation are essential. Key application areas include:

- **Power Generation:** Driving pumps, fans, and compressors
- **Petrochemical and Refinery Plants:** Operating high-power process equipment
- **Mining and Cement Industry:** Crushing, grinding, and conveyor systems
- **Water Treatment and Infrastructure:** Large pumping stations and water transfer systems
- **Steel and Heavy Industry:** Furnace blowers, rolling mills, and mixers



MILKING MACHINE MOTORS

Special
Series





GAMAK  

TYPE	IP54	NO. OF PHASES	3	NO. OF POLES	4
MODEL	8547	INSULATION CLASS	F	PROTECTION CLASS	IP54
V	220	A	4.5	NO. OF THERMAL PROTECTORS	2
				NO. OF THERMAL PROTECTORS	2

© PERMA 2015
C11907
Made in Bangladesh. REC 80000

Milking Machine Motors

Developed to increase efficiency in modern milk production and maximize milking hygiene, Gamak Milking Motors are the ideal solution for farm and industrial milking applications with their durable structure and high performance operation. Providing constant vacuum power thanks to its powerful motor structure, Gamak milking motors help the milking process to take place in a fast, controlled and animal-friendly way. Its energy-efficient design reduces operating costs, while its long-life components ensure minimum maintenance.

Milking Machine Motors Features	
Power Range	0,55 - 1,5 kW
Pole	4
Frame	90
Protection Class	IP55
Insulation Class	F (155°C)
Cooling Mode	TEFC- IC411

Our milking motors, which are produced as single-phase permanent circuit capacitor, switch and cable, can also be produced as double output upon request.



COMPRESSOR MOTORS

Special
Series

The image shows a row of industrial compressor motors in a factory. The motors are white and grey, with some orange accents. They are arranged in a line, receding into the background. The floor is a light-colored, polished concrete. A large, dark blue diagonal shape covers the left side of the image, creating a modern, industrial aesthetic.



Compressor Motors

Gamak Compressor motors, designed specifically for use in compressors, deliver the required power with high performance thanks to reinforced insulation (IVIC-C), the use of insulated bearings above 110 kW, and a 1.15 service factor.

Compressor Motors Features	
Power Range	0,55 – 250 kW
Number of Poles	2 and 4
Efficiency Class	IE3 ve IE4
Frame	132-315
Frame Material	Aluminum and Cast Iron
Service Factor	1,15
Protection Class	IP55
Insulation Class	H (180°C)
Temperature Rise Class	F (105 K)
Cooling Method	IC411-TEFC
Thermal Protection	Thermistor Protected

Our Product Features:

- 1,15 Service factor
- Reinforced insulation (IVIC-C)
- Insulated bearings (for 110 kW and above)
- H class insulation and PTC sensor
- Front side shaft locking
- RAL 7045 (Telegray 1) paint

**For motors with service factor 1.2 or 1.25, please consult the Gamak.*

Our compressor motors share the same dimensional specifications as our standard three-phase asynchronous motors.



GENERAL INFORMATION

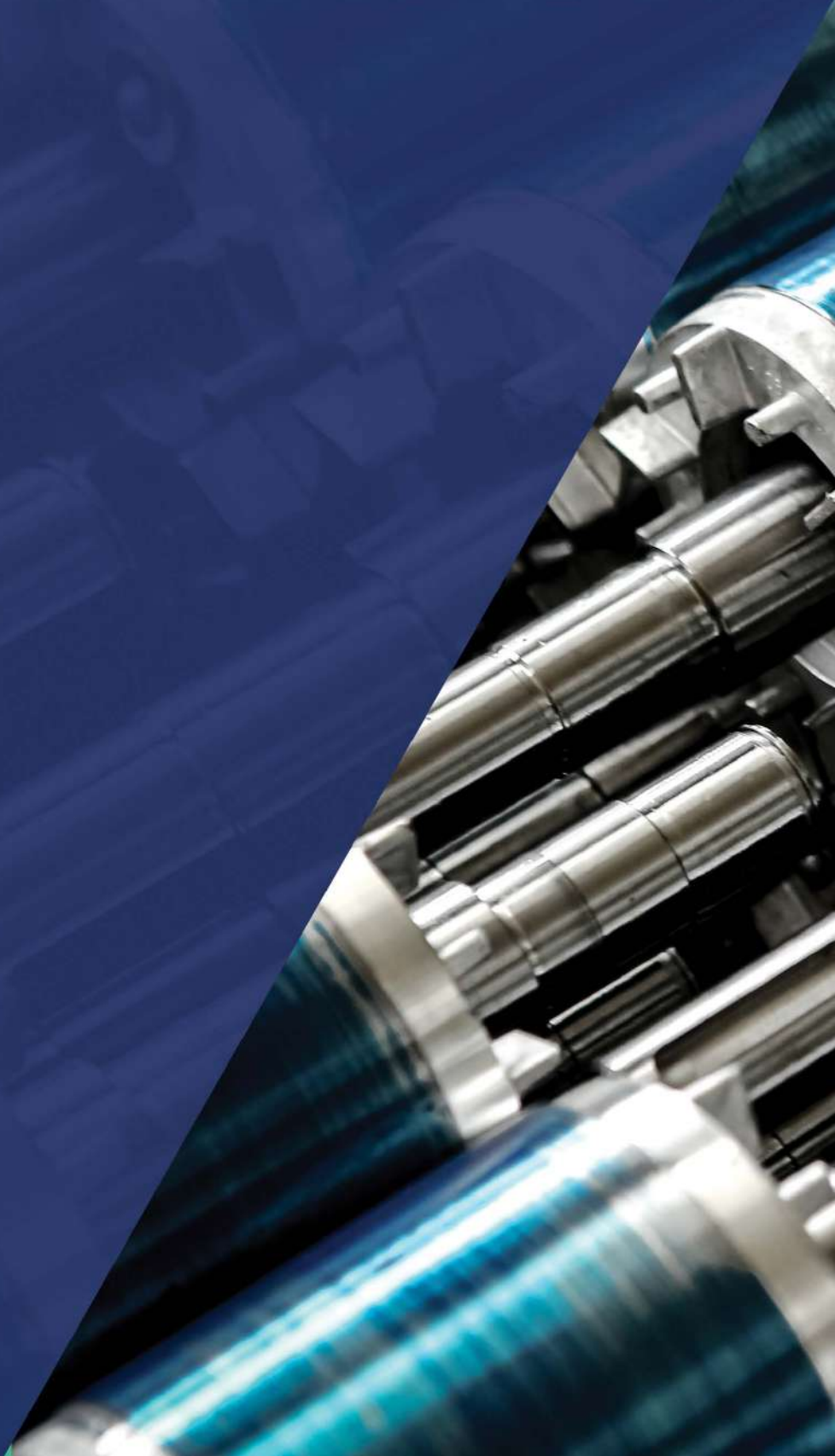

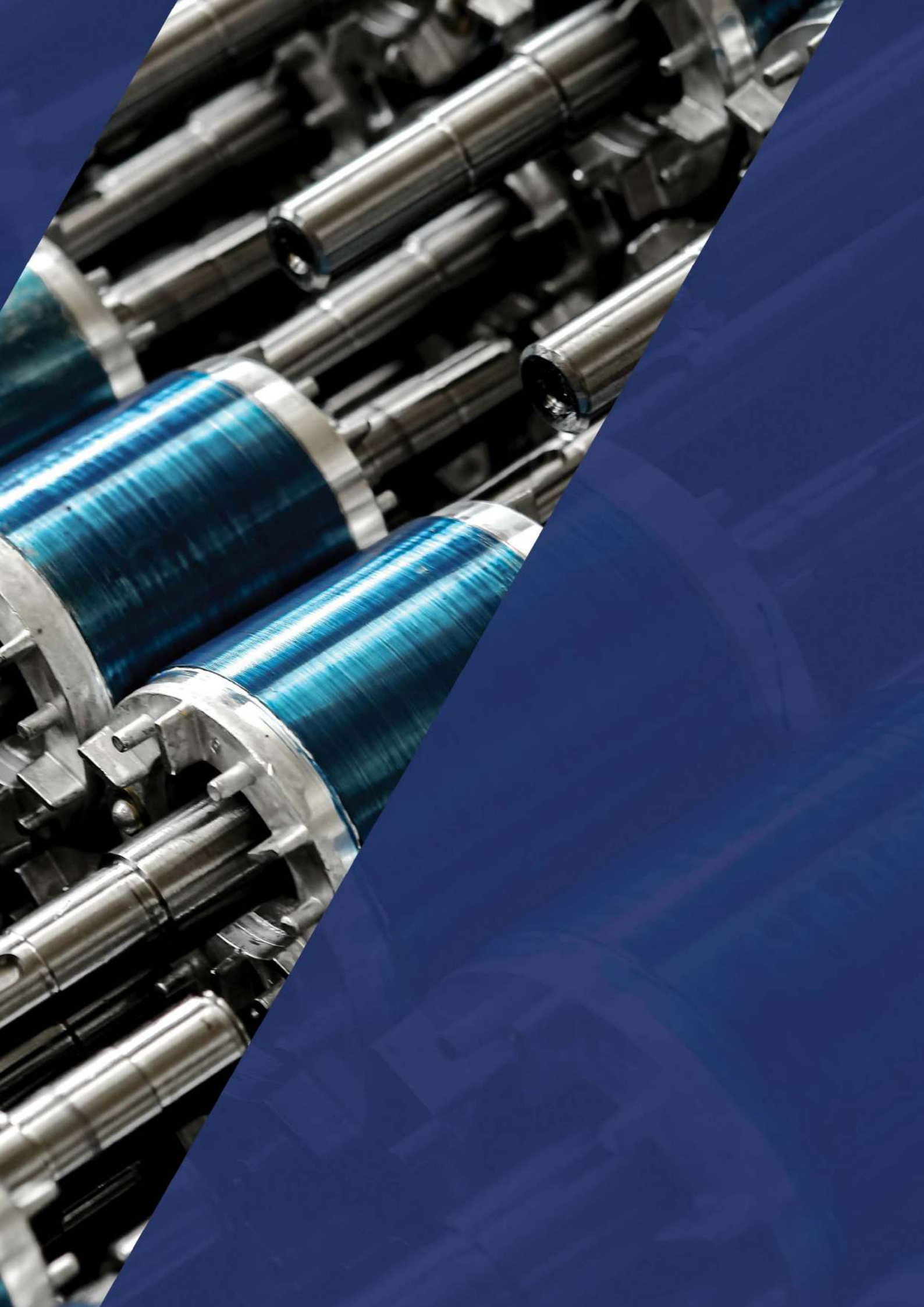

Speed Control Applications

Variable frequency driver are electronic devices that allow the speed of caged induction motors to be adjusted over a wide range by means of a variable frequency and voltage power supply. When supplied by a properly designed frequency converter, the speed of a cage induction motor can be adjusted steplessly and practically losslessly. In frequency converters, 2 different methods are used to control the mains voltage coming to the motor by switching; PAM (Pulse Amplitude Modulation) and the commonly used PWM (Pulse Width Modulation). The alternating voltage coming to the motor is first converted to direct voltage and then the three-phase output voltage is generated by slicing the direct voltage in the PWM method and without slicing in the PAM method.

Speed Adjustment of Cage Induction Motors

Today, cage asynchronous motors, whose speed is regulated by frequency converters, are used in every type of automated plant and equipment. The main benefits of lossless speed regulation over a wide range are energy savings, process and quality improvement. Calculations and measurements have shown that the best operating characteristics over the speed ranges found in practice are usually achieved with 4 pole induction motors. Therefore, this number of poles should be preferred in practice. However, when very low or high speeds are required, other pole numbers can be selected. The rated voltage of the motor is normally taken equal to the mains voltage so that the motor can be fed directly from the mains when the frequency converter fails. Asynchronous motors used with frequency converters are standard, but specially designed motors may be required for large powers. The common feature of all frequency converters is the increase in motor losses compared to direct supply from the grid. Due to this increase caused by the presence of harmonics in voltage and current, an induction motor fed from a frequency converter may not be able to deliver its rated power. In practice, following the IEC Recommendation, it is appropriate to reduce the rated power by 0-20%. In selecting the power reduction multiplier for a particular motor, the temperature backup of that motor should be taken into account (IEC 60034-17: Application guide for frequency converter-fed cage induction motors).

Due to the high voltage rise rate and the possibility of high instantaneous voltages, the insulation systems of asynchronous motors fed from a frequency converter may be stressed more than those fed from the mains. This increase in stress depends not only on the leakage reactance of the motor but also on the frequency of the frequency converter and the cable length between the frequency converter and the motor. The cable length, filter requirements and, in some cases, the use of special insulation systems are issues that need to be examined. In practice, the cable length should be as short as possible, which is why induction motors integrated with frequency converters (wireless direct connection) in the Gamak manufacturing program are recommended for variable speed applications.

Double cage or deep groove rotor construction, especially in large motors, should be avoided as this design causes high harmonic losses. Since the motor does not need to have a high starting torque when fed from a frequency converter, different cage designs may be more suitable. However, it should be kept in mind that in case of frequency converter failure, direct starting is not guaranteed, especially for constant torque drives, as induction motors with special cage rotors will be fed directly from the grid. On the other hand, an induction motor fed from a frequency converter may generate more noise due to harmonics than one fed from the grid. This noise can be reduced by proper motor and frequency converter design.

Another effect of feeding from a frequency converter is that voltages can be induced on the motor shaft. If these voltages rise to significant values, the resulting currents can damage bearings and cause premature failure. Although this type of failure is rarely encountered, isolation of the bearings from the drive side may be recommended for operational safety.

Operating Above and Below Rated Speed in Speed Control Applications;

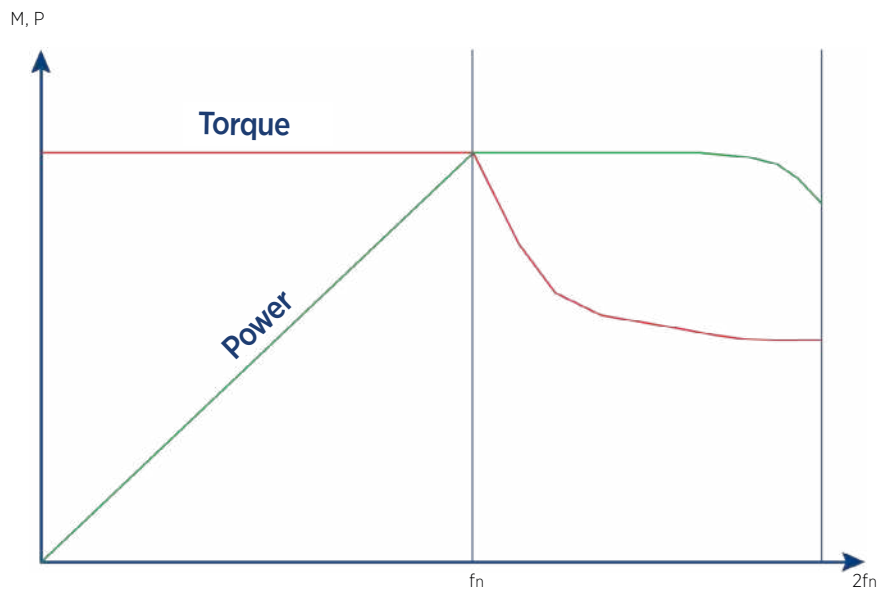

The curve above shows how the motor power and torque change below and above the rated speed of the motor. As can be seen from the curve, it is possible to obtain constant torque from motors below rated speed, and constant power can be obtained above rated speed, but above about 85 Hz, field attenuation increases losses and this causes a decrease in power.

Operation Below Rated Speed;

If the supply voltage is reduced proportionally to the frequency when the frequency is reduced, the motor with constant magnetic flux can be loaded at constant torque. If the torque is kept constant, the current and power coefficient do not change. For the torque to remain constant at low frequencies, the voltage must take a value greater than proportional to frequency. This compensates for the voltage drop across the stator resistance. In load applications such as centrifugal pumps and ventilators with variable torque requirements where the torque decreases with speed, it should be taken into account that the voltage should be less than proportional to the frequency when selecting a frequency converter. At low speeds, the cooling air produced by the motor impeller decreases in proportion to the speed. In applications requiring constant torque, the heat generated in the motor does not change as the magnetic flux remains constant when the speed decreases, so the cooling air of the impeller is not sufficient. The heat generated in the motor cannot be completely removed and the reduction of iron losses at low speeds cannot fully compensate for the disadvantages caused by the lack of cooling. In this case, it may be necessary to reduce the output power of the engine or to provide forced (independent) cooling.

The manufacturer should be contacted about the necessity of forced cooling.

Encoder Usage;

The use of encoders can be requested for closed-loop control for the need for constant torque at very low speeds and for precise speed adjustment. If an encoder is requested, the rear shaft output is specially manufactured and the encoder is installed. We use hollow shaft encoders, the technical details of the encoder to be used are determined by the user and if requested, the encoder is supplied by us or supplied by the user or the encoder supplied by the user is mounted on the motor.

The main points to consider when choosing an encoder are as follows:

- Number of Pulses
- Mechanical measurement (female shaft encoder)
- Supply voltage
- Signal type

In applications that require operation at low speeds, the use of an encoder is generally preferred. In such applications, a forced cooling kit is used to ensure sufficient motor cooling. On the following page, an image of the motor equipped with an encoder and a forced cooling kit is shown.



**POWER
TO
ENERGIZE
LIFE**

Forced Cooling Kit

The illustration below shows the connection method of the forced cooling kit that works continuously independent of the motor shaft. The table shows the total lengths of the motors with the forced cooling kit.

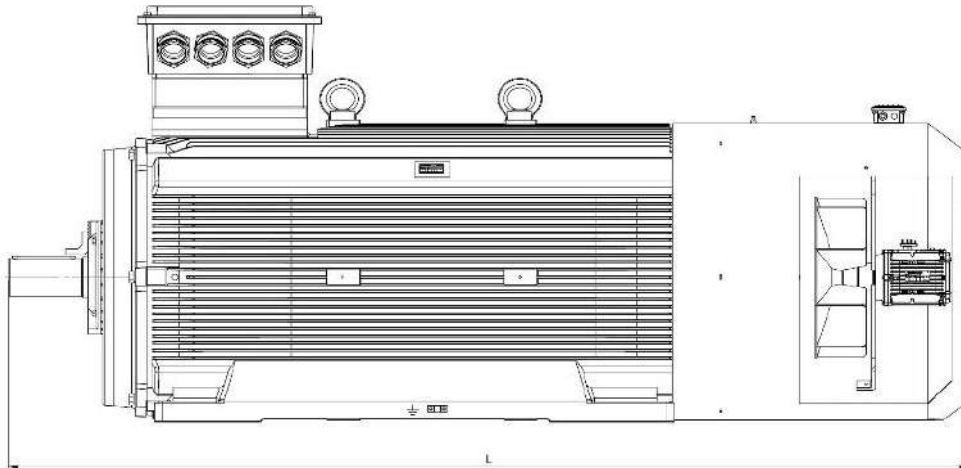

Frame Size		Poles	L (mm)	Frame Size		Poles	L (mm)
71	M	2-4-6-8	374	225	S	2	1056
80	M	2-4-6-8	407		M	4-6-8	1086
	H	2-4-6-8	424	2		1149	
90	S	2-4-6-8	446	250	M	2-4-6-8	1151
	L		470		280	MS	2-4-6-8
	H		496	315		MS	2
100	L	540	L		4-6-8	1436	
	H	575			2	1476	
112	M	2-4-6-8	549	LH	4-6-8	1506	
	H		578		2	1586	
132	S	2	687	355	M	2	1619
	M	4-6-8	628			4-6-8	1727
		2	732			2	1749
160	M	4-6-8	673	L	4-6-8	1857	
	L	2-4-6-8	844		400	L	2
180	M	2-4-6-8	933	H		4-6-8	2079
	L		970		4-6-8	2104	
200	L	2-4-6-8	1094			4-6-8	2604

Operation Above Rated Speed;

In general, since frequency converters cannot supply a voltage greater than the mains voltage, when the frequency increases above the rated value, the voltage/frequency ratio decreases and the magnetic field and flux of the motor weaken, so that the motor can deliver rated power above the rated speed, but the torque is reduced. Depending on the overturning moment at rated operation, the motor can be operated at constant power up to the speed at which the power starts to decrease. At higher frequencies, severe field weakening increases slippage, slippage increases copper losses and, in addition, the skin effect, which causes heat loss in the grooves, can start to have a detrimental effect. Although losses at high speeds limit the motor power to its rated value, the maximum allowable speed of the motor is determined by other factors.

- Overturning moment: Decreases with increasing frequency.
- Bearing design: Due to increased vibrations above the rated speed, the mechanical stress of the bearings increases and the life of the bearings and grease is reduced. In such a case, it is recommended to balance the rotors in S (special) degree (DIN EN 60 034-14).

2 poles - 3000 RPM

Power (kW)	Frame Size	Mechanical Limit Speed (RPM)	Maximum Operating Frequency (RPM)
0,09...5,5	56...112	6000	100
5,5...11	132	5600	90
11...22	160	4800	80
22 - 30	180	4600	76
30...55	200 - 225	4500	75
55...500	250 - 355	3600	60
450...1000	400 - 450	3400	56

4 pole - 1500 RPM

Power (kW)	Frame Size	Mechanical Limit Speed (RPM)	Maximum Operating Frequency (RPM)
0,06...11	56 - 132	4200	140
11...55	160 - 225	4200	140
55...110	250 - 280	3600	120
110...250	315	2800	93
250...500	355	2400	80
450...1000	400 - 450	2200	73

6 poles - 1000 RPM

Power (kW)	Frame Size	Mechanical Limit Speed (RPM)	Maximum Operating Frequency (RPM)
0,18...5,5	71...132	3900	195
7,5...15	160...180	3600	180
18,5...37	200...225	3200	160
37 - 75	250 - 280	3000	150
75...160	315	2600	130
160...355	355	2400	120
355...8000	400	2200	110

8 poles - 750 RPM

Power (kW)	Frame Size	Mechanical Limit Speed (RPM)	Maximum Operating Frequency (RPM)
0,09...11	71...180	3200	213
15...45	200...280	3000	200
55...132	315	2600	173
132...315	355	2400	160
315...630	400 - 450	2200	147

Shaft Tensions

Another problem that can generally be encountered in motors of 400 kW and above (in theory 110kW and above, but in practice it is encountered in larger powers) is the shaft voltages on the motor frame. Due to the asymmetrical structure created by the speed controller in the motor flux, currents are generated in the motor frame and these currents pass over the bearings and complete the circuit. The currents flowing through the bearings can cause the bearings to fail over time. The most effective method to prevent this is to use isolated bearings. In this case, the rear bearing housings of the motor are isolated or isolated bearings are used. Gamak isolated bearing motor manufacturing is available if required.

Configuration Table to be Selected in Drive Applications

The VFD-motor system is a continuous electrical and physical chain consisting of the frequency converter (inverter), connecting cable, filtering devices (dU/dt filter, sine or EMC filter), the motor itself and the supply transformer or mains.

Each of these elements has a direct influence on the characteristics of the whole system and especially on the operating conditions of the motor. Since all the elements are interconnected, they must be determined based on the architecture of the whole system, not just by increasing insulation in the motor design. The more information known at the design stage about the frequency converter, filter type, cable length and design, EMC conditions and supply characteristics, the more accurately the motor will fit into the system. This can significantly extend insulation life, reduce Bearing damage and ensure stable operation when exposed to inverter signals. The table below includes filter selection, insulation type and test voltage levels according to motor power, voltage and cable length.

U _n / Condition	P < 110 kW	110kW ≤ P < 350 kW or IEC 315-355 Frame Size	P ≥ 350 kW or IEC 400-450 Frame Size	Notes (IEC 60034-25)	If CM filter is not possible
U ≤ 500 V	Standard motor	Standard + Insulated Bearing	Standard + Insulated Bearing + CM filter	Filters not required if dv/dt ≤ 5 kV/μs	-
U ≤ 500 V, cable > 150 m	Standard + dU/dt filter or Reinforced Insulation	Standard + dU/dt filter or Reinforced insulation	Standard + CM filter + dU/dt filter	If dv/dt > 5 kV/μs requires filtering	Brush + Insulated Bearing or Insulated End-Shields
U=500-600 V	Reinforced insulation + dU/dt filter	Standard + dU/dt filter or Reinforced Insolation + Insulated Bearing	Reinforced insulation + dU/dt filter + CM filter	Filter required if dv/dt > 5 kV/μs	Brush + Insulated Bearing or Insulated End-Shields
U=500-600 V, kablo > 150 m	Reinforced insulation + dU/dt filter	Reinforced insulation + dU/dt filter + Insulated Bearing	Reinforced insulation + dU/dt filter + CM filter + Insulated Bearing	PD-resistant insulation required	Insulated Bearing or Insulated End-Shields + Shaft Grounding
U=600-690 V	Reinforced insulation + dU/dt filter	Reinforced insulation + dU/dt filter + Insulated Bearing	Reinforced insulation + dU/dt filter + CM filter	Up to 7800 V/μs. Reinforced insulation required	Grounding Brush
U= 600-690 V, kablo > 150 m	Reinforced insulation + dU/dt filter	Reinforced insulation + dU/dt filter + Insulated Bearing	Reinforced insulation + Insulated Bearing + CM filter	Filters + extra PD protection mandatory	2 Insulated Bearing or Insulated End-Shields + Shaft Grounding

Note:

The withstand voltage of the motor with standard insulation is 1800 V. Reinforced insulation refers to voltage levels above 1800 V depending on power, cable length or use of filters. The voltage limits that the motor can withstand are limited to the standard voltage values determined in accordance with the operating voltage. Operating conditions above these voltage ratings are not guaranteed.

Important Note:

There is a risk of capacitive discharge current in motors below 110kW due to common mode voltages at the output of the speed controller. The most effective method of preventing capacitive discharge current is proper grounding as specified in IEC 60034-25 and, if possible, placing a common-mode filter at the output of the speed controller.

Operation and Maintenance Information

Transportation

Motors must be lifted with lifting eyes. The capacity of the lifting device used must be at least the weight of the motor. For the motor weight, refer to the operating rating sheets of the respective engine. When transporting a motor assembly with the retaining plate, never lift it with the motor lifting eye. In this case, the lifting eyes of the retaining plate must be used. If the motors have cylindrical roller bearings or angular contact ball bearings, a locking device is provided to prevent damage to the bearings during transportation. This arrangement must be removed before the engines are put into operation.

Ventilation and Cooling

In the plastic propellers of the motors, two opposing tongues injected together with the propeller enter the circumferential groove in the shaft and fix the propeller in the axial direction. The wedge, also injected with the plastic propeller, fixes the propeller in the radial (rotational) direction. To remove the propellers, the tongues must be removed from the groove and held in the open position with a flat sheet support inserted into the rail. Always use appropriate tools when installing or removing the impellers. The distance between the cooling air inlet and the wall or other machinery must be at least one quarter of the diameter of the air inlet. The hot exhaust air from the motor must not be drawn back for cooling. Vertically mounted motors with the air inlet at the top must be protected with a special additional End-Shields to prevent water and foreign objects from entering the motor. The air vents of the propeller housing End-Shields must be cleaned regularly when necessary. For this purpose, oil-free compressed air should be blown out of the engine.

Water Drain Holes

The water drainage holes, sealed with plastic plugs, are located at the lowest point of the flange or End-Shields in accordance with the construction and installation arrangement of the motor and must always be kept clean. If the plugs are removed, the degree of protection of the motor housing is reduced to IP 44.

Interference and Elimination

The motors are manufactured with interference rating G according to VDE 0875. This interference rating is sufficient for industrial applications. If interference ratings of N (Normal) or A (Low) are desired for residential areas, it is recommended that interference measurements are carried out at the place of use and appropriate remedial measures are taken.

Installation

Motors must be installed on a level and vibration-free foundation. All motor feet must be fully seated. Under unfavorable operating conditions, the temperature of the housing parts may reach or exceed 100°C. These parts must not be touched and/or must be prevented from being touched. Temperature-sensitive parts such as normal cables and electronic components must not be attached to or touch the hot part of the frame.

Alignment

Motors must always be aligned sensitively. This is especially important when they are directly connected to the work machine. Incorrect alignment can cause bearing distortion, vibration and even shaft breakage. As soon as bearing distortion or vibration is detected in a motor, the alignment must be checked. When connecting the motor to the work machine, the shafts must be aligned radially and angularly using a dial indicator. For this purpose, both coupling halves are rotated 90° together and measured at four points. It is recommended to recheck the alignment after the machines have reached thermal equilibrium.

Waste Product Disposal

End-of-life electric motors must be disposed of by the end user in accordance with the Waste Electrical and Electronic Equipment (WEEE) Regulation. The relevant WEEE PRODUCT DISPOSAL GUIDE document is available on the our website www.gamak.com.

Clutches and Pulleys

If the clutches and pulleys used apply radial or axial shaft loads during operation, the catalog values of the allowable mechanical forces must not be exceeded. Only flexible couplings must be used, as inflexible couplings require a special bearing design. Transmission elements must only be installed and removed using suitable tools. Bearings must never be subjected to pressure or impact. Statistics show that about 70% of motor failures are caused by bearing failure. Most bearing failures are caused by an incorrect operation in the installation of a clutch or pulley. If a belt drive is used, the motor must be fixed to the retaining rails in order to set the belt removal correctly. The shafts must be parallel, the pulleys aligned and the bottom side of the belt attractive. Over-tensioning the belt can damage the shaft and bearings.

Balancing

The rotors are dynamically balanced with a HALF WEDGE placed on the shaft end. For this reason, shaft elements such as clutch, pulley or propeller installed on the shaft end must be balanced on a flat mullion before the keyway is opened. In order to prevent them from falling off during transportation, a guard End-Shields is used on the shaft end. If the motor, transmission couplings, etc. are to be operated before they are installed on the shaft end, the wedge must be securely fixed to the shaft end and necessary precautions must be taken to prevent ejection.

Insulation Resistance

The insulation resistance of newly built or newly wound motors is normally very good. However, under unfavorable conditions of transportation, storage or standstill, moisture and/or dirt can reduce the insulation resistance to an undesirably low level. Before an electric motor is put into operation for the first time or after a long period of storage or standstill, the insulation resistance of the windings should be measured. The measurement is made by applying 500V DC and the final resistance reading is taken after approximately one minute. During or immediately after the measurement, terminals with dangerous voltages must not be touched. Also, if supply cables are connected, make sure that the circuit is clearly disconnected. This applies to both main and auxiliary circuits and especially to condensation heating circuits. Although a limit value for the smallest value of the insulation resistance cannot be given, the following table can be a guide for measurements at 25°C winding temperature.

Limit values at rated voltage < 1kV

Measuring voltage	500 V, DC
Lowest insulation resistance of new, cleaned or repaired windings	10 MΩ
Critical value of specific insulation resistance after long operating times	0.5 MΩ /kV

Commissioning

After installing a motor, the following checks and tests should be carried out:

- Compliance of insulation and operating conditions with license plate information,
- The motor is correctly positioned and aligned,
- Proper installation of shaft elements,
- Adequate insulation resistance,
- Direction of rotation,
- Unobstructed flow of cooling air,
- Free rotation of the rotor,
- All clamping elements and electrical connections are tight,
- Good grounding connections,
- Proper lubrication of bearings,
- Fittings are installed, properly connected and maintainable,
- All protective measures must be taken against touching moving and stressed parts,
- If there is an motor brake, it must be properly installed, connected and maintained,
- Allow the motor to run at idle until it reaches full speed,
- Pay attention to noises and vibrations in the bearings and End-Shields,
- If the motor does not turn smoothly or if there are unusual noises, remove the motor from the circuit. Investigate the cause of the noise when the motor is decelerating. If the fault disappears on deceleration, the cause is electrical or magnetic. Otherwise, the cause is mechanical.
- If the motor runs well at idle, it is loaded at rated power. Observe the smoothness of rotation and note the supply voltage and motor operating values.
- Note the temperature of the winding, bearings and housing until thermal equilibrium is reached.
- To stop the motor, open the breaker and allow it to stop without braking and activate the water condensation heater, if fitted.

To ensure that the thermal protection system does not cause damage or injury when the engine is cold, the temperature sensors must be connected and checked in such a way as to prevent the engine from starting again unexpectedly.

The above checklist cannot End-Shields every eventuality. Therefore, other measures can be taken by the installation and commissioning engineer who is familiar with the special conditions of the plant and location and any additional instructions.

Maintenance of Bearing Housing

Re-lubrication of Motors with Lubrication Nipples

For bearing lubrication during motor assembly, the use of SHELL GADUS S2 V100 C3 grease or the high-performance greases specified in the table is recommended. For lubricated motors, information on the type, quantity and lubrication interval of the grease is defined on the label. The lubrication intervals indicated on the label apply to normal continuous operating conditions, i.e. rated load and speed, vibration-free operation, clutch drive, coolant ambient temperature 40°C and for the high quality bearing greases specified in the selection chart below.

K3K Greases	K3N Greases (Higher temperature)
BP / ENERGREASE LS3	SHELL G3
MOBIL MOBILUX 3	SHELL RT3
ARAL / ARALU	ARAL ARALUB 4340
B H L3 ELF / ROLEXA 3	ESSO / BEACON / 3

The lubrication intervals given below are for a bearing temperature of 70°C. If the temperature increases for some reason, such as belt drive, these intervals are shortened. Conversely, if the bearing temperature decreases, such as at low ambient temperature, the lubrication intervals become longer. Approximately, if the bearing temperature increases or decreases by 15K, the lubrication interval is halved or doubled. However, regardless of the operating time, the grease should be replaced after 3 years of operation at the latest due to aging. To replace the grease, the motor is disassembled to the extent necessary, the bearings are thoroughly cleaned or replaced, then new grease is applied. Fill the cavities of the bearings with grease up to the level of the side surfaces. To avoid excessive lubrication in bearing assemblies, grease is not put inside the bearing caps. Recommended greases contain lithium soap as thickener and mineral oil as base oil. Mineral oil contains additives to prevent oxidation and corrosion (Bearing greases K3N DiN 51 825). The amount of grease to be filled into a bearing should be approximately 1/3 of the internal cavity volume. The amount of grease to be used by finger calculation in grams should be at least as much as the inner diameter of the bearing in mm. In general, different grease types should not be mixed with each other. Mixing greases with different types of thickeners can disrupt its composition and physical properties. Even if the thickeners are of the same type, possible differences in additives can have detrimental effects. To ensure uniform distribution of the new grease in the bearing, the bearings must be lubricated with the motor running. Initially, the bearing temperature rises considerably and drops to its normal value after the excess grease has been removed from the bearing.

Re-lubrication Intervals in Lubricated Motors (Hours)

Poles	Frame Size					
	132-160	180-200	225-250	280-315	355-400	450
2	5000	4000	3000	2500	2000	2000
4	10000	8000	6000	5000	4000	3000
≥6	15000	12000	9000	7000	5000	4000

The above table applies to Gamak motor lubricated bearings for installation of the shaft in horizontal position, operating temperature -20 / +40°C, < 80% RH, clean environment. In case of vertical operation of the motor shaft, the lubrication interval should be halved. If the environment is dusty, the lubrication period should be halved.

Lubrication Quantities in Lubricated Motors (Grams)

Poles	Frame Size									
	132	160	180	200	225-250	280	315-355	400	450	
2						35	45	50	-	
4	10	15	20	25	40					
≥6						70	90	90	110	

Depending on the motor construction and operating speeds, lubrication quantities are indicated in the list above.

Bearing Replacement

Remove the ball bearings with a puller after slightly heating the inner ring. Never use a hammer. The inner ring of roller bearings must be heated quickly with a flame and removed with a screw puller. If it still does not come off, grind a Vshaped groove in the inner ring and break it off. Before installing the bearings, check that the parts to be placed on the shaft are in place. Take great care when installing and assembling and observe the cleanliness requirements. Heat the inner rings of ball bearings and roller bearings in oil or air to a temperature of about 80°C, then slide them onto the shaft. Hard impacts must be avoided as they damage the bearings. Fill the bearings with the prescribed grease. When installing single-row angular contact ball bearings, make sure that the wide shoulder of the inner ring and the narrow shoulder of the outer ring face in the opposite direction to the axial thrust in the operating position. Check that the sealing rings are correctly positioned during installation.

Seal Replacement

- Depending on the oil level in the environment, it may often take time for the lubricant to reach the sealing lip. Since this can cause dry friction during initial start-up, the shaft running surface and/or the sealing lip must be thoroughly lubricated with clean oil (the same oil used in the application) immediately before installation. However, the amount of oil applied must not be excessive to the point that it leaks from the back side of the seal; otherwise, it may be mistakenly assumed that the seal is leaking. For seals with a dust lip rubbing against the shaft, apply a thin layer of grease between the two lips. For seals with double dust lips, apply a thin layer of grease between the two dust lips.
- The seal must be installed squarely and axially into its housing.
- The seal must be pressed into position using a suitable installation tool.
- When removing the old seal, the housing/bore must not be damaged or deformed.
- The installation process must be carried out at a constant speed.

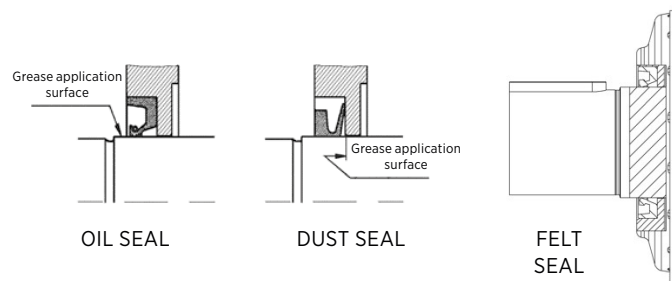



Possible Motor Failures and Remedies

Mechanical Failures							Possible Causes	Solutions
Bearing is excessive hot.	Bearing is crowing.	Bearing is knocking.	Friction noise.	Extremely high temperature.	Radial vibration.	Axial vibration.		
							Excessive grease in the bed.	Throw away excessive grease.
							The bearing is dirty.	Clean or replace the bearing. Check the seals.
							The sealing collar is tightening the shaft.	Better fit or replace the seal seat.
							The belt is over-tensioned.	Decrease the belt tension.
							Coupling is twitching.	Align the machine better.
							Ambient temperature >40°C.	Use special high temperature grease.
							Insufficient lubrication.	Lubricate according to instructions.
							Narrow bearing clearance.	Use bed with larger clearance*.
							Rust in bearing.	Replace bearing, check seals.
							Bearing is twitching.	Check bearing for proper mounting, make the outer ring less tight.
							Excessive bearing clearance.	Use bearing with a narrower clearance.*
							Foreign objects in bearing.	Clean or replace the bearing.
							Scars on the bearing or on the bearing ring	Replace the bearing, avoid vibrations when the motor is not running.
							Rotating parts are rubbing.	Realign them and eliminate the cause.
							Insufficient cooling.	Check the vent of the fan housing, the surface of the motor and, if necessary the fan.
							Imbalance in the motor rotor.	Re-balance the rotor.
							The rotor wobbling due to an inclined shaft.	Consult the manufacturer.
							Imbalance in transmission elements.	Balance the transmission elements.
							Aligning is insufficient.	Align the motor and the work machine sensitively in thermal balance.
							Incompatible transmission (ex. Gear Box).	Check and eliminate the cause.
							The detection surface is not solid.	Check and eliminate the cause.
							Impacts from the heavy machine.	Check and eliminate the cause.

Defects in bearings are sometimes difficult to define. Change the bearing when in doubt.

* Consult the manufacturer.

Possible Motor Failures and Remedies

Electrical Faults										Possible Causes	Solutions
The motor does not start.	Motor is not align well	Knocking noise at start-up.	Knocking noise in operation.	Knocked noise at twice the slip frequencies.	Excessive high temperature when running.	Over temperature when working with full load.	Winding sections are overheating.	Speed decreases when loaded	Opening the protection.		
										Overload.	Reduce the load or choose a larger motor.
										Excessive starting and/or overturning torque.	Reduce the load torque or select a motor with higher torque characteristics.
										Mains voltage low or frequency high.	Correct the supply conditions.
										Mains voltage high or frequency high.	Correct the supply conditions.
										Correct the feeding conditions.	Phase break.
										Check the switch and the supply circuit.	Stator winding connected incorrectly.
										Check the winding connection for inter winding or phase shor circuit.	Check the winding and insulation resistance. Consult the manufacturer.
										Insufficient connection in the cage.	Consult the manufacturer.
										Excessive start-up temperature.	Reduce the starting frequency or recalculate the motor identification.
										Excessive start-up time.	Facilitate the start-up or recalculate the motor identification.
										Defective contact in the switch.	Replace the defective contacts.
										Capacitor is defective.	Check the capacitor voltage, replace it if necessary.









DUDULLU OSB NO:2

